



Owner's Manual

Original Instructions

Commercial Air Conditioners

Direct-current Cassette Type FCU

Applicable Models :

AFCD-30CC/2P

AFCD-40CC/2P

AFCD-50C/2P

AFCD-55C/2P

AFCD-65C/2P

AFCD-75C/2P

AFCD-90C/2P

AFCD-110C/2P

AFCD-120C/2P

Thank you for choosing commercial air conditioners. Please read this Owner' s Manual carefully before operation and retain it for future reference.

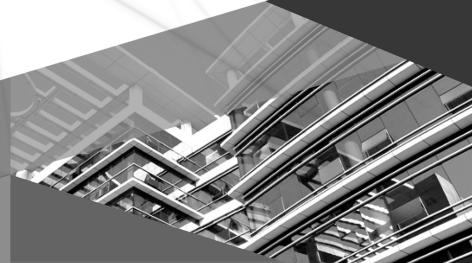

To Users

Thank you for selecting this product. Please read this instruction manual carefully before installing and using the product, so as to master and correctly use the product. In order to guide you to correctly install and use our product and achieve expected operating effect, we hereby instruct as below:

- (1) This equipment should be installed, operated or maintained by the qualified servicemen who have had specific training. During operation, all safety issues covered in the labels, User's Manual and other literature should be followed strictly. This equipment is not intended for use by persons (including children) with reduced physical, sensory or mental capabilities, or lack of experience and knowledge, unless they have been given supervision or instruction concerning use of the appliance by a person responsible for their safety. Children should be supervised to ensure that they do not play with the appliance.
- (2) This product has gone through strict inspection and operational test before leaving the factory. In order to avoid damage due to improper disassembly and inspection, which may impact the normal operation of unit, please do not disassemble the unit by yourself. You can contact our designated dealer or local service center for professional support if necessary.
- (3) When the product is faulted and cannot be operated, please contact our designated dealer or local service center as soon as possible by providing the following information.
 - Contents of nameplate of product (model, cooling/heating capacity, product No., ex-factory date).
 - Malfunction status (specify the situations before and after the error occurs).
- (4) All the illustrations and information in the instruction manual are only for reference. In order to make the product better, we will continuously conduct improvement and innovation without further notice.

Contents

Safety Notices (Please be sure to abide)	1
1 Product Introduction	2
1.1 Working Principle.....	2
1.2 Main Parts	2
1.3 Working Conditions	3
2 Unit Installation.....	3
2.1 Installation Environment	3
2.2 Precautions for Installation	4
2.3 Installation of the Main Unit.....	5
2.4 Installation of Inlet and Outlet Pipes	5
2.5 Installation of the Drain Pipe	6
2.6 Installation of the Water Valve	7
2.7 Electric Wiring	8
2.8 Installation of the Front Panel.....	14
3 Additional Functions.....	15
3.1 Wired Controller	15
3.2 WiFi	15
4 Commissioning and Maintenance	16
4.1 Trial Run	16
4.2 Maintenance.....	17
5 Troubleshooting	18
5.1 Troubleshooting Analysis.....	18
5.2 Error Codes	19

Safety Notices (Please be sure to abide)

 **WARNING:** If not abide strictly, it may cause severe damage to the unit or the people.

 **NOTE:** If not abide strictly, it may cause slight or medium damage to the unit or the people.

WARNING

- This product is only used as a comfort air conditioner.
- Do not violate the welding process, and pipeline must be filled with nitrogen during welding.
- It is strictly forbidden to short-circuit or cancel the pressure switch to avoid abnormal damage to the unit.
- Do not insert fingers or objects into the air supply or return air grille.
- Do not start and stop the air conditioner by unplugging the power cord.
- Do not operate the air conditioner with wet hands.
- Clean the air conditioner only after it is turned off and the power is cut off, otherwise it may lead to electric shock or injuries.
- Do not spray water to the unit or flush the air conditioner with water, otherwise it will cause malfunction or even electric shock hazard.
- Do not let the air conditioner directly exposed to water or moisture and other easily corrosive environment.
- Volatile liquids such as thinner or gasoline will damage the appearance of the air conditioner. Only a soft dry cloth or a damp cloth stained with neutral detergent is allowed to clean the housing of the air conditioner.

NOTE

- Please install the product according to this manual. Please read this manual carefully before operating or maintaining it.
- Installation should be carried out by qualified personnel. Do not install it by yourself. Incorrect installation may cause accidents such as water leakage, electric shock or fire.
- Do not repair the air conditioner by yourself. Wrong maintenance will cause electric shock or fire accidents. Please contact our company's designated customer service center.
- Before installation, please check whether the power supply used is consistent with the power supply required on the nameplate, and check the safety of the power supply. The power supply should be connected after all installation work has been completed.
- The air conditioner should be reliably grounded to avoid the risk of electric shock. Do not connect the ground wire to the gas pipe, water pipe, lightning rod or telephone line.
- Installation of the unit must comply with national and local safety regulations.
- Be sure to use special accessories and parts during installation, otherwise it may cause water leakage, electric shock, fire and other accidents.
- The wire diameter of the power cord should be large enough, and damaged power cord and connecting line must be replaced with a special cable.
- After the power cord is connected, be sure to install the electrical box cover to avoid safety accidents.
- The unit controlled by the wired controller must be connected to the controller before being powered on, otherwise the unit would not be used normally.
- After installation, please check and confirm whether the drainage pipes, connecting pipes and electric cables are connected correctly to prevent accidents such as water leakage, electric shock or fire.
- When you use gas or oil heating devices in the room at the same time, please open the door or window frequently to keep the air circulating and avoid lack of oxygen in the room.
- If an abnormal situation occurs (such as unpleasant smell, etc.), please stop the unit immediately and cut off the main power supply, and then contact our company's designated customer service center. If the air conditioner continues operating under abnormal conditions, the unit would be damaged and it would cause electric shock or fire accidents.

1 Product Introduction

1.1 Working Principle

The fan coil unit is one of the mostly used terminal units in the air conditioning industry. It gets cold (hot) water from the main unit and then does directly heat exchanging with air inside the room for either space cooling or heating.

1.2 Main Parts

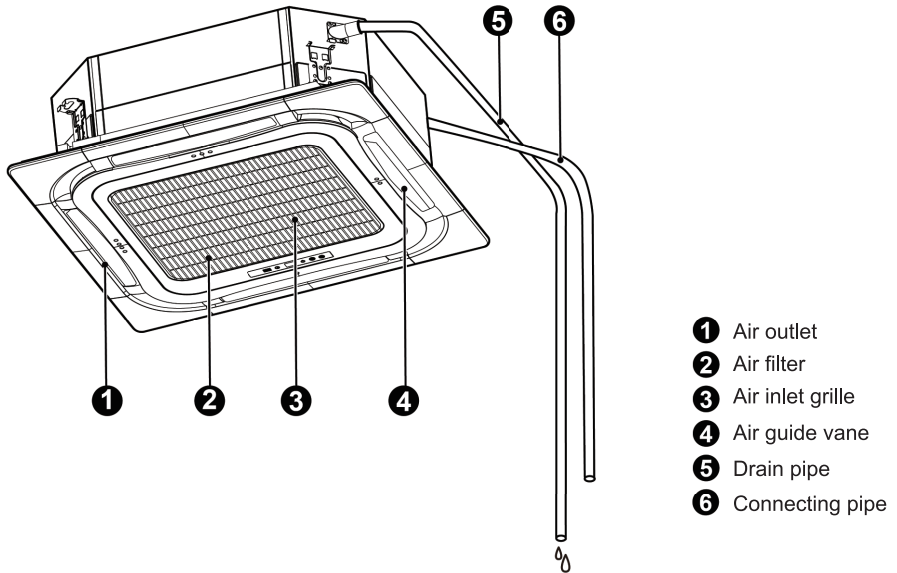

Figure 1-1

Note: it is just for reference and the actual unit will always prevail.

1.3 Working Conditions

- (1) The entering water temperature for cooling must be no less than 5°C, otherwise it would lead to condensate; the entering water temperature for heating must be not higher than 80°C (60°C usually), otherwise it would lead to corrosion of copper tubes or abnormal noise.
- (2) The working environment temperature for cooling ranges 16~40°C and ranges 10~35°C for heating. Besides, the relative humidity is or less than 80%.
- (3) The water quality is required to be clean and soft. Use of untreated water would lead to poor water quality, scaling, corrosion of copper tubes, deteriorated heat exchanging and other issues.
- (4) The heat exchanger has undergone a pressure-resistant air tightness test of 2.8MPa and a high-precision vacuum box helium leak detection, and the maximum allowable working pressure of the unit is 1.6MPa.
- (5) This product is a kind of comfort air conditioning, and is not allowed to be installed where there are corrosive, explosive and inflammable substances or smog; otherwise it would lead to operation failure, shortened service life, fire hazard or even severe injuries. Special air conditioners are required for where mentioned above.

2 Unit Installation

2.1 Installation Environment

- (1) Ensure that the top hanger is strength enough to bear the weight of the unit.
- (2) Ensure drain water is easily led out through the drain pipe.
- (3) Import and export are barrier-free and in good air circulation.
- (4) Required installation distance and maintenance space should be kept, as shown in the figure below.
- (5) Keep the unit away from heat sources, and places with leaked flammable gas and smoke.
- (6) The unit, power lines and connecting cables shall be at least 1 meter away from the TV and radio. This is to prevent them from suffering image interference and noise (even if there is a distance of 1 meter, noise may occur in case of strong wave.).

Unit:mm

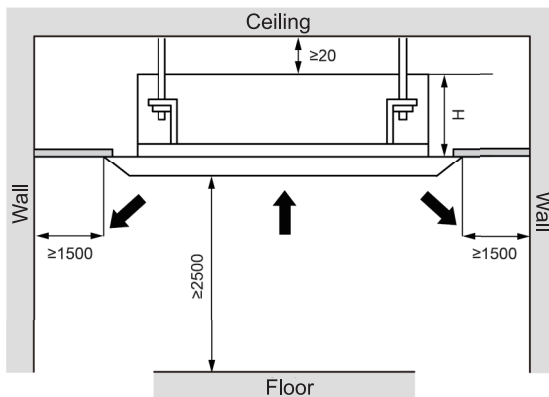

Figure 2-1

Model	H(mm)
AFCD-30CC/2P, AFCD-40CC/2P	305
AFCD-50C/2P, AFCD-55C/2P, AFCD-65C/2P	235
AFCD-75C/2P	275
AFCD-90C/2P, AFCD-110C/2P	325
AFCD-120C/2P	315

Note: "H" indicates the depth of the unit.

NOTE

- Installation of the unit must comply with national and local safety regulations.
- Installation quality of the unit directly affects the normal use. Users must not install it by themselves. After purchasing this product, please contact our company's designated customer service center and qualified installers will undertake installation and commissioning.
- The power supply should be connected after all installation work has been completed.

2.2 Precautions for Installation

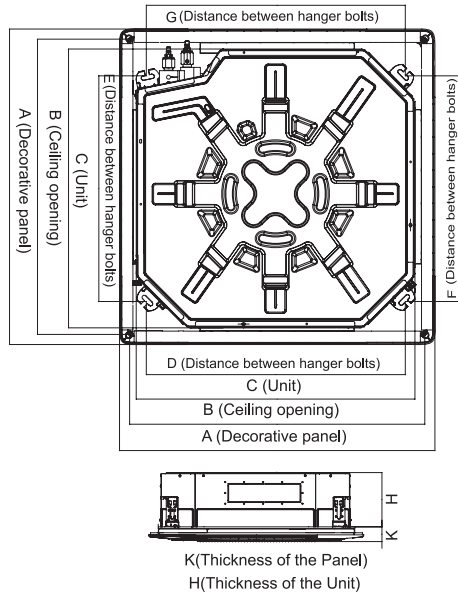

Figure 2-2

NOTE

Drilling at the ceiling and Installation of the unit must be carried out by qualified personnel.

Model	A	B	C	D	E	F	G	H	K
AFCD-30CC/2P,AFCD-40CC/2P	620	580	570	530	505	530	550	260	65
AFCD-50C/2P, AFCD-55C/2P, AFCD-65C/2P	950	890	840	680	780	680	780	200	65
AFCD-75C/2P	950	890	840	680	780	680	780	240	65
AFCD-90C/2P, AFCD-110C/2P	950	890	840	680	780	680	780	290	65
AFCD-120C/2P	1040	975	910	790	840	790	840	293	85

2.3 Installation of the Main Unit

- (1) Bolt hole drilling and bolt installation: the length of the bolt can be selected according to the height of the room, and the bolt is prepared by the user.
- (2) Preliminary installation of the unit: install the hoisting screw on the expansion bolt, and then attach the hanger seat to the hoisting screw. Be sure to use nuts and washers at the upper and lower ends of the hanger seat respectively to fix the hanger seat firmly. Use the washer locating plate to prevent the washer from falling off.
- (3) Use of the installation cardboard: For the size of the ceiling opening, please refer to the installation cardboard.
- (4) Check whether the unit is horizontal. If the unit is inclined, it may cause water dripping.

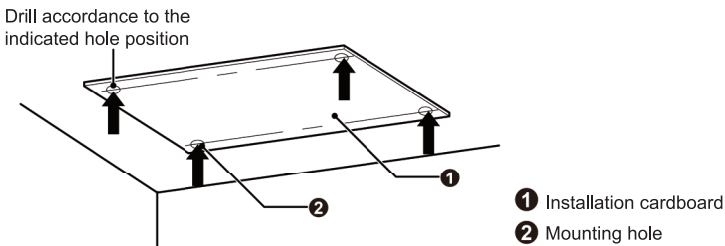

Figure 2-3

2.4 Installation of Inlet and Outlet Pipes

- (1) Both the torque wrench and ordinary wrench should be used for installing and uninstalling the water pipes, as shown in the figure below.
- (2) The inlet and outlet pipes both are G3/4 threaded. Before connection, wrap the thread for 2-3 cycles with the Teflon tape for better sealing.
- (3) After the inlet and outlet pipes have been connected, start the water pump to check if they leak or not. Then, expel air inside the pipe system through the exhaust valve and insulate it properly as shown in the figure below.
- (4) Wrap the connectors with sponge and do insulation to the exhaust valve.

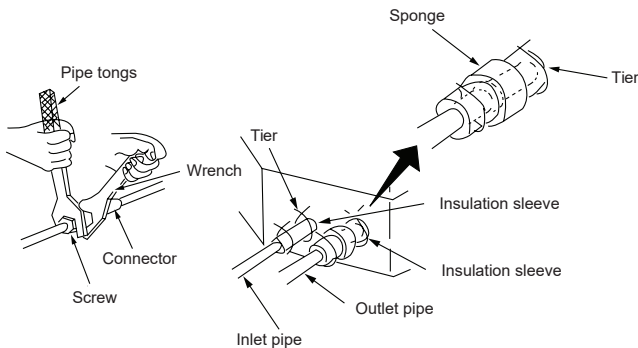

Figure 2-4

2.5 Installation of the Drain Pipe

2.5.1 Installation Instructions

▲ NOTE

- Condensate drainage pipes are strictly prohibited from being connected to sewage pipes, fecal pipes and other pipes that are easy to produce corrosion and peculiar smell, so as to avoid peculiar smell entering the room and corroding the unit.
- It is strictly forbidden to connect the condensate drainage pipe to the rainwater pipe to prevent the serious consequences such as property damage and personal injury caused by rainwater backflow.
- The condensate drain pipe of the air conditioner shall be connected to the special drainage system of the air conditioner.
- The shorter the drain pipe, the better, and keep the inclination of at least 1% ~ 2% downward to facilitate the discharge of condensed water.
- Insulate the indoor drain hose and drain socket to avoid dew dripping!

(1) When multiple drain pipes are connected, they should be arranged as shown in the figure below.

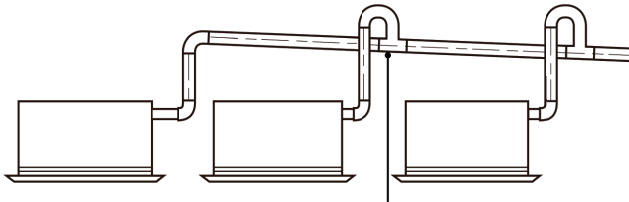

Drain pipe with T-type connectors

Figure 2-5

(2) The installation height of the drain riser should be less than B. The drain riser must be set with an inclination angle of 1~2 degree towards the drainage direction. If the drain riser is required to form a right angle with the unit, the lifting height must be less than C.

Unit:mm

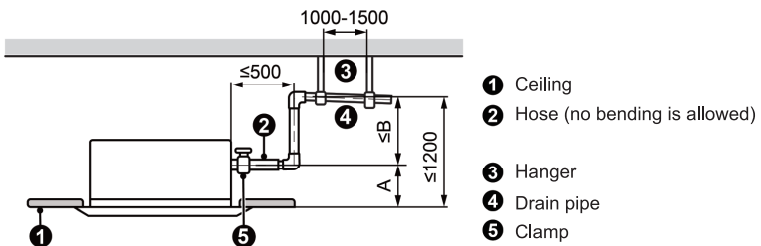

Figure 2-6

Model	A	B	C
AFCD-30CC/2P, AFCD-40CC/2P	265	935	885
AFCD-50C/2P, AFCD-55C/2P, AFCD-65C/2P	200	1000	950
AFCD-75C/2P, AFCD-90C/2P AFCD-110C/2P, AFCD-120C/2P	220	980	930

2.5.2 Testing to the Drain System

- (1) Inject about 1L of purified water from the air outlet to the drain pan. Be careful not to sprinkle water on the water pump and other electrical components. Switch the unit to the cooling, the fan or dry mode. At this time, the water pump is turned on, and then observe whether drainage of the water pump is normal through the drain port.
- (2) During the test, determine whether the water flow through the pipeline correctly, and carefully observe the connection to ensure that the connection does not leak.
- (3) If the unit is installed in a new house, it is recommended to test before the ceiling is decorated.

Unit:mm

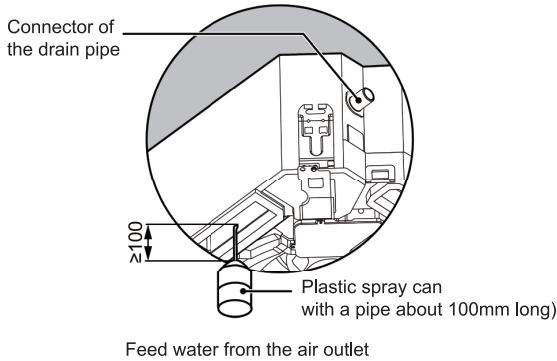

Figure 2-7

2.6 Installation of the Water Valve

2.6.1 Installation Instructions

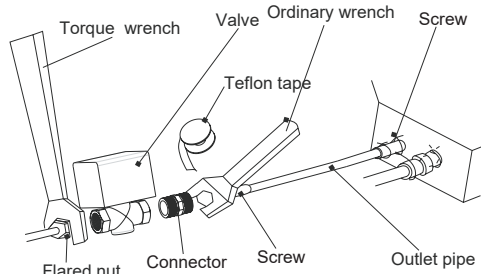

Figure 2-8

- (1) See the figure above for installation of the water valve. Firstly, connect one end of the water pipe to the water inlet of the unit, and then connect the other end to water valve. During installation, both the torque wrench and ordinary wrench should be used. For the former, the torque should be less than 80N.m. In addition, connectors must be tightened.
- (2) After the connector, the water valve and the water pipes have been finished, start the water pump and see if they leak or not.
- (3) Insulate the water valve and the pipe with sponge.
- (4) Check the wiring carefully and then start the water pump and unit to see if they work normally.

2.7 Electric Wiring

2.7.1 Steps for Electric Wiring

- (1) Open the electric box and pull the power lines and connection lines of the electric water valve through the rubber rings to the terminal board. After connection, be sure to fix the power and water valve cables with clamps.
- (2) When matching the optional accessories, connect the signal line through the rubber ring to the terminal board of the controller. After connection, be sure to secure the cable with clamps.
- (3) When connecting the optional cable, power must be cut off first, and then power on after connection has been finished.
- (4) Be sure to perform wiring in accordance with the wiring diagram at the unit.
- (5) After the test run is qualified, place the electrical box cover back.
- (6) The ambient temperature sensor and pipeline temperature sensor shown in the figure below only collect the ambient temperature and pipeline temperature, and are not used for other purposes.
- (7) Specifications of the fuse configured for the unit: T3.15AH 250V
- (8) When the wired controller is being installed, the earthing wire of the wired controller should be connected to the earthing screw at the bottom of the unit. Do not connect it to the earthing wire of the power cable, which may cause electromagnetic interference.

◆ AFCD-30CC/2P, AFCD-40CC/2P

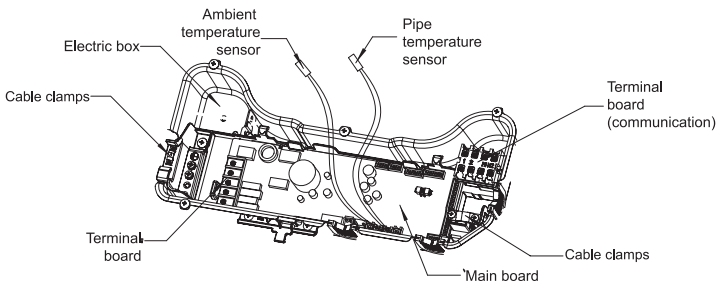

Figure 2-8

◆ AFCD-50C/2P, AFCD-55C/2P, AFCD-65C/2P, AFCD-75C/2P, AFCD-90C/2P, AFCD-110C/2P

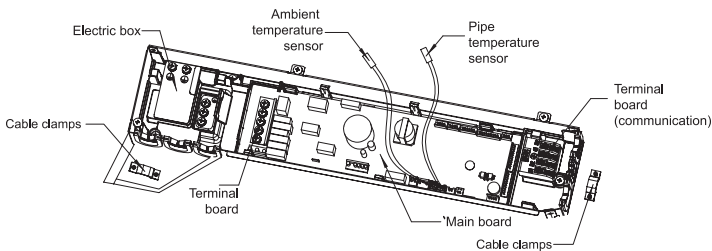
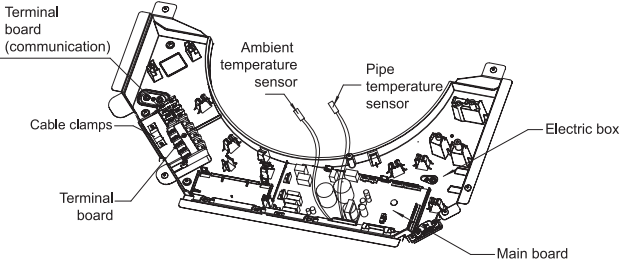

Figure 2-9

◆ AFCD-120C/2P



Note: figures above are for reference only. If there is any difference, the actual unit shall prevail.

2.7.3 External Wiring Diagram

◆AFCD-30CC/2PAFCD-40CC/2P

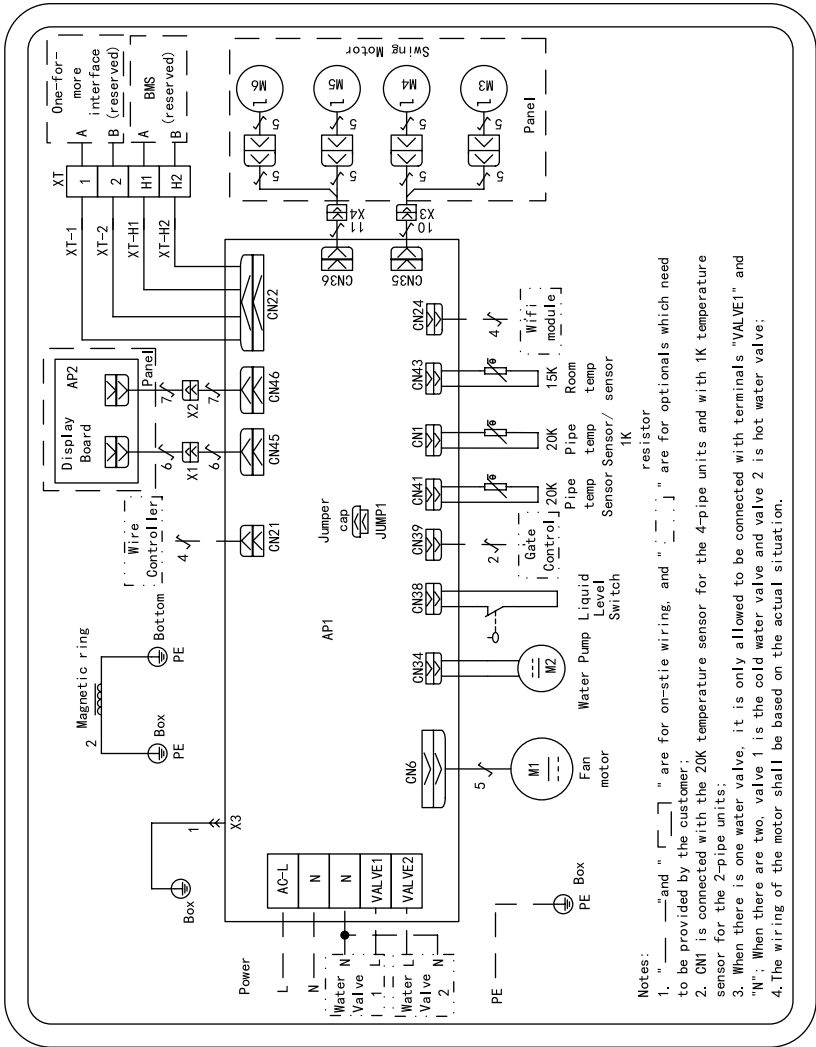

Figure 2-10

◆ AFCD-50C/2P, AFCD-55C/2P, AFCD-65C/2P, AFCD-75C/2P, AFCD-90C/2P, AFCD-110C/2P

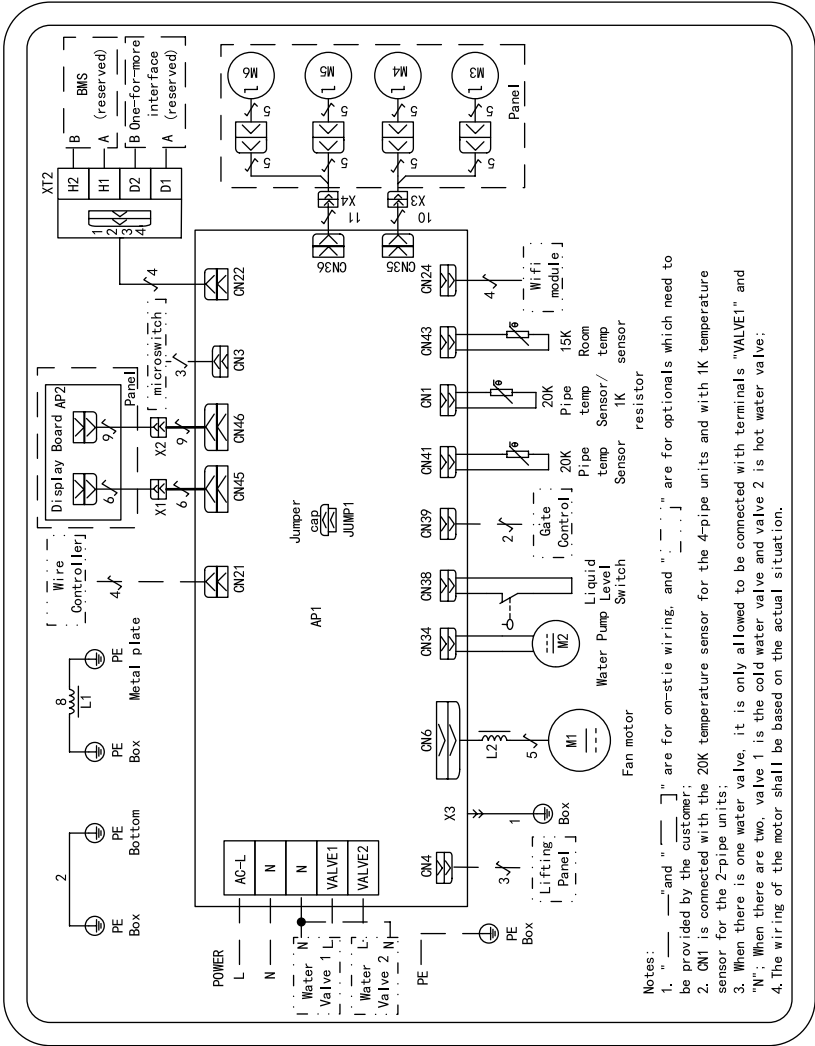

Figure 2-11

◆ AFCD-120C/2P

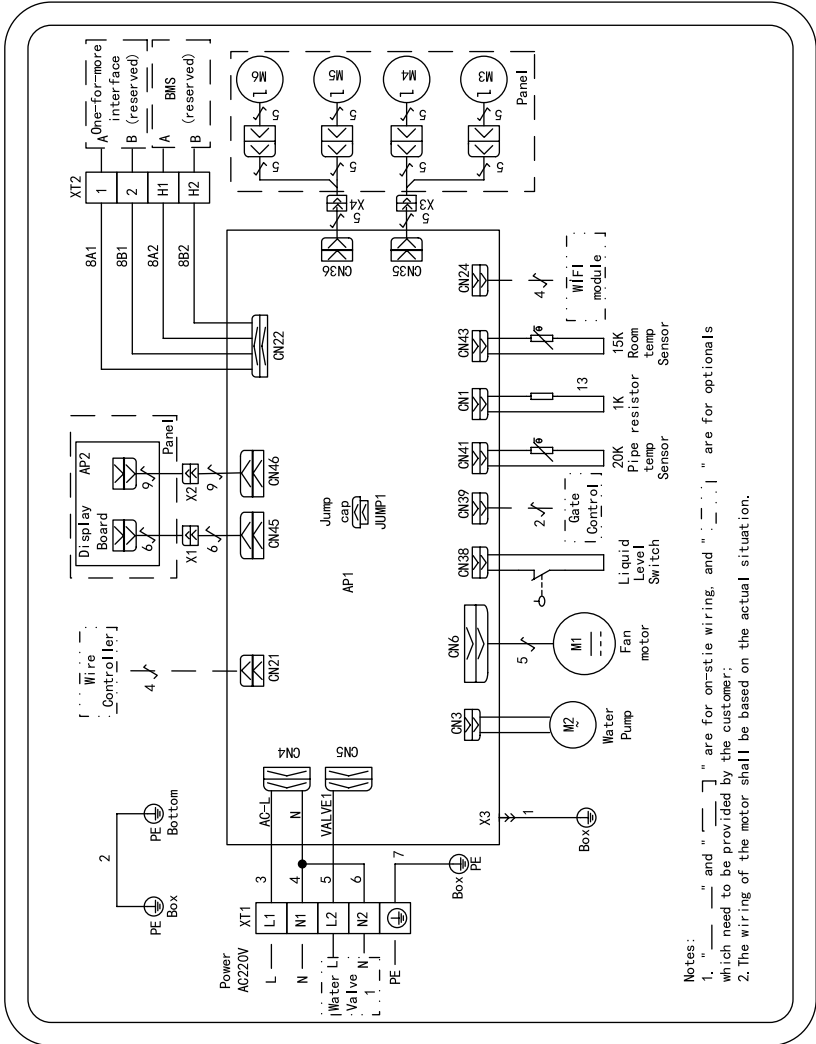

Figure 2-12

Note: the above wiring diagram is for reference, and the actual wiring on the unit always prevails.

2.8 Installation of the Front Panel

2.8.1 Precautions

NOTE

- Inappropriate screw tightness will cause air leakage in the panel, which may cause condensate water to drip.
- After tightening the screws, if there is still a gap between the ceiling and the decorative panel, readjust the height of the indoor unit. After the panel is installed, make sure that there is no gap between the unit and the panel!

2.8.2 Installation Instructions

- (1) Open the four corner covers of the panel, mark "PIPING SIDE" on one of the corners, and adjust the direction of the panel so that the corner is in the same position as the connecting pipe of the indoor unit.
- (2) Temporarily install the panel on the unit. During installing, hang the buckles at the four corners of the panel on the hooks of the main unit, as shown in the figure below.

Unit:mm

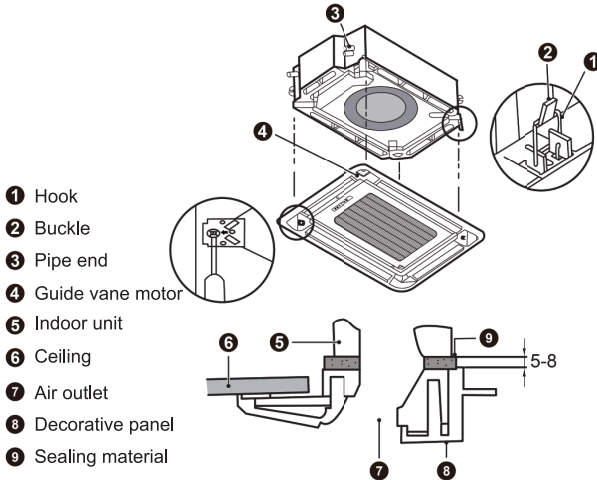

Figure 2-13

- (3) Open the air inlet grille on the panel, connect lines of the lamp board and the air sweep motor, and be careful not to cause gaps between the panel and the main body, otherwise it will cause air leakage and condensation.

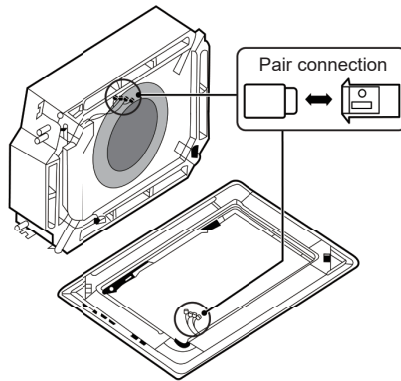

Figure 2-14

- (4) Tighten the bolts at the 4 corners of the panel respectively, and install the panel firmly without gaps.
- (5) Reinstall the air inlet grille.

3 Additional Functions

3.1 Wired Controller

- (1) The wired controller is optional. You should purchase our wired controller to realize functions stated below.
- (2) In addition to basic functions, the wired controller can set seven fan speeds, whether to stop the fan when reaching the temperature point, and whether to set the anti-cold/anti-hot air operation mode, etc.
- (3) The wired controller can also realize group control, filter screen cleaning reminder, etc. Please contact our after-sales personnel for details.

3.2 WiFi

- (1) WiFi is an optional function. You should purchase our WiFi module to realize this function, and this function is not applicable to some models.
- (2) When the WiFi module model has been equipped and the remote controller is turned off, press MODE and TURBO keys at the same time for 10 seconds to reset the WiFi module, and the buzzer will buzz. At this time, the network can be matched through the mobile phone.
- (3) WiFi resetting will clear personal information stored in the device, such as WiFi SSID and WiFi password, etc.
- (4) For the specific use, please refer to the instructions of the WiFi module.

4 Commissioning and Maintenance

4.1 Trial Run

(1) Preparation before Trial Run

- Do not power the unit on until all installation has been finished.
- Control and power lines are connected correctly and tightly.
- All cut-off valves should be opened.
- All odds and ends should be removed .

(2) Trial Run Method

- Press the “Mode” button to select the desired running mode, "cooling", "heating" or "fan". Then, observe it to see if it can work normally.

(3) Commissioning Method

When the wired controller is unavailable, the wireless controller can be put into use as stated below.

How the start the unit with the wireless controller: power on the FCU. Under the ON state of the controller, press the “Turbo” button within five seconds and the FUC will put into forced operation. At this time, the operation of the unit can be controlled by this wireless controller, with the corresponding icons displayed at the controller. Then, by pressing the ON/OFF button, commissioning will end. During commissioning, when there is no any operation in five minutes, commissioning also will end. After that, stop the FCU by pressing the ON/OFF button.

(4) Instructions for Emergency Operation

When the wired and wireless controllers are lost, the unit can be started through press-button operation stated as below.

- Press “AUTO” three seconds to start or stop the unit. The default operation condition is cooling, automatic fan speed, air swing and 24°C.
- Under ON status, the current mode will be changed by each press to “AUTO” in the sequence of "cooling"—"dry"—"fan"—"heating"—"cooling".
- Under ON status, press “AUTO” for three seconds, the unit will be stopped.
- The anti-cold and anti-hot air protection are shielded.

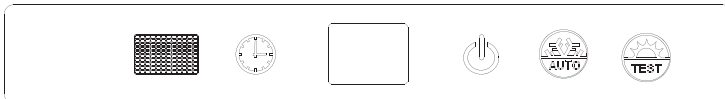

Figure 3-1

(5) It is strictly prohibited to stop the unit while cold water is continuously flowing, otherwise condensation may form on the surface of the unit and attached objects. If the unit is stopped for more than 8 hours, close the inlet and outlet water valves and stop water supply; if water supply cannot be stopped, adjust the unit to the low speed mode.

(6) Anti-freeze protection: during the period when the unit is stopped running, if the ambient temperature is above 2°C, keep the coils filled with water to reduce rusting; if the ambient temperature is 2°C or below, one of the following anti-freeze measures for the coils must be taken:

- Ensure the circulation pump runs continuously so that water flows within the coils;
- Add an appropriate concentration of antifreeze solution to the water system.
- Water in the coils must be drained out completely using high-pressure gas.

Note: if the unit is temporarily not operating when the ambient temperature is 2°C or below, the water in the coils (system) must be drained out completely using high-pressure gas; otherwise, the coils would freeze and crack. If antifreeze solution is added, consult a professional water treatment company. The manufacturer assumes no responsibility for damage to the unit caused by unauthorized addition or addition not in accordance with requirements.

4.2 Maintenance

WARNING

- Clean the air conditioner only after it is turned off and the power is cut off. Otherwise, you may get an electric shock or injury.
- When cleaning the air conditioner, pay special attention to the use of a stable standing platform.
- Do not use hot water above 45°C to avoid fading or deformation.
- Do not dry on the fire, otherwise the filter will catch fire or deform.
- Volatile liquids such as thinner or gasoline will damage the air conditioner components (only use a soft dry cloth or a damp cloth with neutral detergent to clean the outer filter screen of the air conditioner).
- If there is any abnormality, please contact our designated customer service center for guidance.
- Non-approved personnel are not allowed to open the indoor air inlet grille.

4.2.1 How to Clean the Air Filter

- (1) During cleaning, remove the air filter screen at the air inlet, use a vacuum cleaner or rinse the filter screen with water. When the filter screen is dirty (oily), it can be cleaned with warm water (below 45°C) with neutral detergent, and then put it in a cool place to dry.
- (2) When the air conditioner is used in a dusty environment, the air filter should be cleaned more frequently. (usually once every two weeks).

4.2.2 Maintenance before Seasonal Use

- (1) Check whether the air inlet and outlet of the unit are blocked.
- (2) Check whether the grounding wire is in good condition.
- (3) Check whether the line connection is in good condition.
- (4) Whether there is a fault code on the display screen of the wired controller after the power is turned on.

4.2.3 Maintenance after Seasonal Use

- (1) When the weather is fine, operate the unit for half a day to dry the inside of the unit.
- (2) If the air conditioner will not be used for a long time, please turn off the power to save energy; after turning off the power, the text on the wired controller display will disappear.

4.2.4 Water Quality Requirements

- (1) During cleaning, remove the air filter located at the air intake. Clean the filter using a vacuum cleaner or by rinsing with water. If the filter is heavily soiled (e.g., with oil stains), wash it with warm water containing neutral detergent (temperature below 45°C), then dry it in a cool, shaded area.
- (2) In environments with heavy dust, the air filter should be cleaned frequently (generally once every two weeks).
- (3) The air conditioner must only be cleaned after it has been powered off and the power supply has been disconnected. Failure to do so may result in electric shock or personal injury.
- (4) Do not rinse the unit with water, as this would pose a risk of electric shock.
- (5) Non-professionals are prohibited from opening the unit's air intake grille.

(6) The unit requires clean, soft water to prevent scaling on the coils. Scaling can impair heat exchange efficiency, increase water resistance, and negatively affect pump performance. Furthermore, long-term corrosion may lead to coil leakage. The specific water quality requirements are listed in the table below:

Item		Baseline value	Trend	
			Corrosion	Scaling
Basic items	pH value (25°C)	6.5~8.0	○	○
	Electric conductivity (25°C)	μS/cm	<800	○
	Chloride ion Cl ⁻	mg(Cl ⁻)/L	<200	○
	Sulfate ion SO ₄ ²⁻	mg(SO ₄ ²⁻)/L	<200	○
	Acid consumption (pH4.8)	mg(CaCO ₃)/L	<100	○
	Full hardness	mg(CaCO ₃)/L	<200	○
Reference Items	Ferrum Fe	mg(Fe)/L	<1.0	○
	Sulfide ion S ²⁻	mg(S ²⁻)/L	Undetectable	○
	Ammonium ion NH ₄ ⁺	mg(NH ₄ ⁺)/L	<1.0	○
	Silicon dioxide SiO ₂	mg(SiO ₂)/L	<50	○

Notes: "○" indicates there is a possibility of scaling or corrosion.

5 Troubleshooting

5.1 Troubleshooting Analysis

No.	Symptoms	Possible Causes
1	The air conditioner cannot be started.	There is no power supply.
		The leakage switch trips off caused by leakage of the air conditioner.
		Line voltage is too low.
		The control loop fails.
2	Although the air conditioner can be started, it stops soon.	The inlet and outlet of the unit are blocked.
3	Poor cooling effect	The air filter is dirty or blocked.
		There is a heat source or too many people in the room
		The door or windows are open.
		There are obstacles at the air inlet and outlet.
		The temperature set point is too high.

No.	Symptoms	Possible Causes
4	Poor heating effect	The air filter is dirty or blocked.
		The door or windows are not closed tightly.
		The room temperature set point is too low.
5	The fan does not start during heating/cooling	During heating, as the temperature of the heat exchanger is too low, the fan is not allowed to start in order to avoid blowing cold air.
		During cooling, as the temperature of the heat exchanger is high, the fan is not allowed to start in order to avoid blowing hot air.

NOTE

- It is recommended not to shut down the unit through power failure. If doing so, because the fan is not stopped stably and the control board needs a certain time for initialization, once power on again in about 10 seconds after power failure, the light board will not display until about 8 seconds later. This situation is not abnormal and is not required to be treated.
- If the air conditioner still cannot operate normally after the above inspections and treatments, please stop the air conditioner immediately and contact our company's designated customer service center for professional maintenance.

5.2 Error Codes

Error Codes	Description
E0	Water pump error
E6	Communication error
E9	Full water error
F0	Return air temperature bulb error
F1	Cooling coils temperature bulb error
F5	Wired controller temperature bulb error
E8	DC motor stall protection
C5	Jumper cap error
HF	WiFi module communication error



66139914872