



Owner's Manual

Original Instructions

Commercial Air Conditioners

Wall Mounted Type Fan Coil Unit

Models:

AFCD-23WM/2P

AFCD-28WM/2P

AFCD-40WM/2P

AFCD-45WM/2P

AFCD-53WM/2P

AFCD-60WM/2P

AFCD-75WM/2P

AFCD-85WM/2P

Thank you for choosing commercial air conditioners. Please read this Owner' s Manual carefully before operation and retain it for future reference.

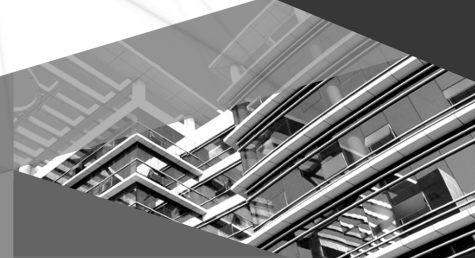

To Users

Thank you for selecting this product. Please read this instruction manual carefully before installing and using the product, so as to master and correctly use the product. In order to guide you to correctly install and use our product and achieve expected operating effect, we hereby instruct as below:

- (1) This equipment should be installed, operated or maintained by the qualified servicemen who have had specific training. During operation, all safety issues covered in the labels, User's Manual and other literature should be followed strictly. This equipment is not intended for use by persons (including children) with reduced physical, sensory or mental capabilities, or lack of experience and knowledge, unless they have been given supervision or instruction concerning use of the appliance by a person responsible for their safety. Children should be supervised to ensure that they do not play with the appliance.
- (2) This product has gone through strict inspection and operational test before leaving the factory. In order to avoid damage due to improper disassembly and inspection, which may impact the normal operation of unit, please do not disassemble the unit by yourself. You can contact our designated dealer or local service center for professional support if necessary.
- (3) When the product is faulted and cannot be operated, please contact our designated dealer or local service center as soon as possible by providing the following information.
 - Contents of nameplate of product (model, cooling/heating capacity, product No., ex-factory date).
 - Malfunction status (specify the situations before and after the error occurs).
- (4) All the illustrations and information in the instruction manual are only for reference. In order to make the product better, we will continuously conduct improvement and innovation without further notice.

Contents

Safety Notices (Please be sure to abide)	1
Part One: Fan Coil Unit	5
1. Product Introduction	5
1.1 Working Principle.....	5
1.2 Main Parts	5
1.3 Working Conditions	5
2. Installation Instructions	6
2.1 Requirements on Installation Location	6
2.2 Outline Dimensions	6
2.3 Installation of the Rear Panel	7
2.4 Piping Holes for Installation	7
2.5 Piping and Wiring	7
2.6 Installation of the Drain Pipe	8
2.7 Installation of the the Inlet and Outlet Pipe.....	8
2.8 Installation of the Water Damper	9
2.9 Electric Wiring	10
2.9.1 Precautions	10
2.9.2 Wiring Steps.....	10
2.9.3 Wiring Guidance for Reserved Connecting Lines	11
2.9.4 Wiring Guidance for Group Control.....	12
2.9.5 Wiring Guidance for the Remote Monitoring System.....	12
2.9.6 Wiring Guidance for the Access Control System	13
2.9.7 Guides for the DIP Setting	13
2.9.8 Guides for WIFI.....	13
2.9.9 Electric Wiring Diagrams.....	14
2.9.10 Other Guidances	16
3. Commissioning and Maintenance	16
3.1 Inspection after Installation.....	16
3.2 Trial Operation	17
3.2.1 Before Trial Operation	17
3.2.2 Trial Operation Steps	17
3.3 Air Exhaust	17
3.4 Maintenance Method	18

3.4.1 Cleaning Panel.....	18
3.4.2 Cleaning the Air Filters.....	18
4. Troubleshooting	19
4.1 Error List.....	19
4.2 Check after the Usage Season	19
4.3 Troubleshooting.....	19
4.4 Error Codes	21
4.5 Service Center.....	21
Part Two: Remote Controller YAP1F	22
1. Remote Controller YAP1F	22
1.1 Button Name and Function Introduction	22
2. ON/OFF	23
3. Selecting Operation Mode	23
4. Setting Temperature	23
5. Adjusting Fan Speed	23
6. Setting Turbo Function	24
7. Setting Swing Function.....	24
8. Viewing Ambient Temperature	24
9. Setting Health Function	25
10. Setting Clock.....	25
11. Setting Timer.....	25
12. Setting Sleep Function.....	25
13. Setting X-FAN Function	26
14. Setting Light Function	26
15. Setting Child Lock.....	26
16. Switching Temperature Scale.....	26
17. Resetting WiFi.....	26
18. Replacing Batteries	26











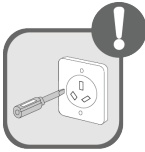

Safety Notices (Please be sure to abide)

 **WARNING:** If not abide strictly, it may cause severe damage to the unit or the people.









 **NOTE:** If not abide strictly, it may cause slight or medium damage to the unit or the people.



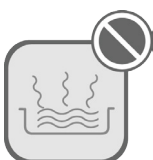

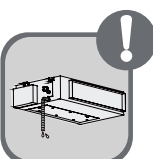



 This sign indicates that the operation must be prohibited. Improper operation may cause severe damage or death to people.

 This sign indicates that the items must be observed. Improper operation may cause damage to people or property.

 WARNING			
	Please perform installation in accordance with this manual and read it carefully prior to startup and service.		Installation should be done by sales agents or qualified servicemen. Do not do it personally, as incorrect installation would lead to water leakage, electrocution, fire hazards etc.
	Before installation, check for power supply and see if it complies with that on the nameplate. Besides, check for safety of the power supply.		This unit should be grounded and there should be grounding lines for the power socket so as to prevent electrocution. Do not connect the grounding lines to the gas lines, water lines, lightning rod or telephone lines.
	Specialized components and parts should be used for installation; otherwise it would lead to water leakage, electrocution, fire hazards etc.		Size of the power lines should be large enough. Power lines and other electric connection lines should be replaced by specialized cables.
	When wiring of power lines is finished, remember to install a electric box to prevent safety accidents.		When installation is finished, check for connection of drain lines, water lines and electric lines, as incorrect connection would lead to water leakage, electrocution, fire hazards etc.
	Do not start or stop the unit by drawing out or plugging in the power plug.		Do not let the children play with this unit.
	Do not operate this unit with wet hands.		Do not clean this unit until the unit is turn off and the power supply is cut off, otherwise it would lead to electrocution or personal injury.

⚠ WARNING

	<p>Do not spray or rinse this unit with water, as it would lead to malfunction or electrocution.</p>		<p>Do not let this unit exposed to moist, wet or corrosive environment.</p>
	<p>Volatile liquid like thinner or petroleum would damage appearance of this unit. (Only soft dry cloth and cloth with neutral detergent can be used to clean the outer casing of this unit.)</p>		<p>Do not repair this unit by yourself, as incorrect repair would lead to electrocution or fire hazards. Please contact ASAMI after-sales center and repair should be done by the qualified servicemen.</p>
	<p>Entering and leaving water lines, condensate lines and valves should be thermal insulated so as to prevent from dewing in summer.</p>		<p>Don't insert your hands or stick into the air intake or outlet vents.</p>
	<p>Never splice the power cord or use an extended cord. It can cause overheating or fire.</p>		<p>Keep combustible spray away from the units more than 1.5m. It can cause a fire or explosion.</p>
	<p>Don't block the air intake of the FCU. It can decrease the FCU capacity or cause a malfunction.</p>		

 NOTE			
	<p>During operation, do not insert fingers or other objects into the moving parts, which would lead to unnecessary injuries.</p>		<p>Please cut off the power supply when this unit is not used for long time in consideration of safety.</p>
	<p>When there is something unusual (like unusual smell, burning smell, smoke etc.), please turn off the unit and cut off the main power supply at once, and then contact ASAMI after-sales servicemen. If unusual conditions go on, this unit would burn out, or even it would lead to electrocution or fire hazards.</p>		<p>Wiring of power lines and electric connection lines should be secure enough. Terminals also should be tightly fastened. The connection line should not suffer external forces. For the unit equipped with the wired controller, the controller would be powered on firstly; otherwise it would be out of normal use.</p>
	<p>The filter should be cleaned periodically in case that heat exchanging effect would be affected.</p>		<p>Please do freeze protection in winter to prevent copper tubes from cracking.</p>
	<p>Don't leave windows and doors open for a long time while operating the FCU. It can decrease the FCU capacity.</p>		

This appliance is intended to be used by expert or trained users in shops, in light industry and on farms, or for commercial or household use by lay persons.

Installing the unit in the following places may cause malfunction. If it is unavoidable, please consult the local dealer:

- (1) The place with strong heat sources, vapors, flammable or explosive gas, or volatile objects spread in the air.
- (2) The place with high-frequency devices (such as welding machine, medical equipment).
- (3) The place near coast area.
- (4) The place with oil or fumes in the air.
- (5) The place with sulfureted gas.
- (6) Other places with special circumstances.
- (7) Do not use the unit in the immediate surroundings of a laundry, a bath, a shower or a swimming pool.

DISPOSAL: This marking indicates that this product should not be disposed with other household wastes throughout the EU. To prevent possible harm to the environment or human health from uncontrolled waste disposal, recycle it responsibly to promote the sustainable reuse of material resources. To return your used device, please use the return and collection systems or contact the retailer where the product was purchased. They can take this product for environmental safe recycling.



Part One: Fan Coil Unit

1. Product Introduction

1.1 Working Principle

The cold (hot) water entering the heat exchanger will do heat exchanging with air passing through the surface of the heat exchanger to condition the air temperature and humidity. There is no (cold) hot source for this product itself. The running mode depends on the environment temperature and the running mode of the main unit.

1.2 Main Parts

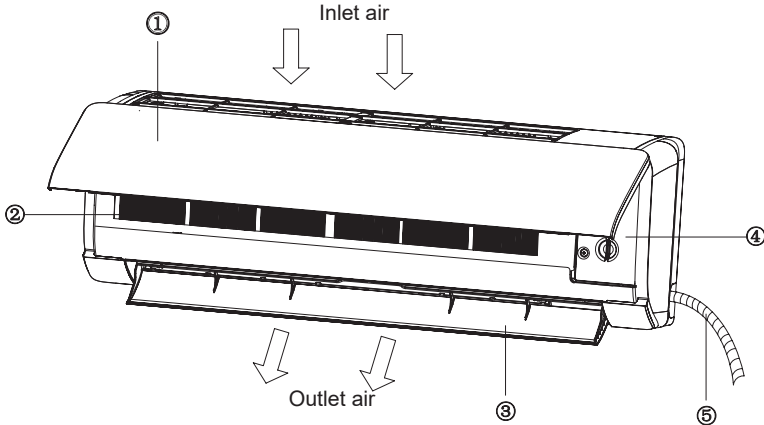

- ① Front panel
- ② Filter
- ③ Guide louver
- ④ Electric box
- ⑤ Inlet/outlet water pipe or drain pipe (back side)

1.3 Working Conditions

- (1) The entering water temperature for cooling is suggested to be no less than 5°C, otherwise it would lead to condensate; the entering water temperature for heating is suggested to be not higher than 60°C, otherwise it would lead to corrosion of copper tubes or abnormal noise.
- (2) The suggested working environment temperature for cooling ranges 16~40°C and ranges 10~30°C for heating. Beside, the relative humidity is or less than 80%.
- (3) The water quality is required to be clean and soft. Use of untreated water would lead to poor water quality, scaling, corrosion of copper tubes, deteriorated heat exchanging and other issues.
- (4) The heat exchanger has undergone a pressure-resistant air tightness test of 2.8MPa and a highprecision vacuum box helium leak detection, and the maximum allowable working pressure of the unit is 1.6MPa.
- (5) This product is a kind of comfort air conditioning, and is not allowed to be installed where there are corrosive, explosive and inflammable substances or smog, or where of high humidity and heat; otherwise it would lead to operation failure, shortened service life, five hazard or even severe injuries. Special air conditioners are required for where mentioned above.

2. Installation Instructions

2.1 Requirements on Installation Location

- (1) Ensure that the installation location has sufficient strength to bear the weight of the unit.
- (2) The drainage pipe works properly.
- (3) There is no obstacle at the air inlet and outlet, and air circulation is good.
- (4) Ensure the installation distance required by the figure below and ensure the space required for maintenance.
- (5) Keep away from heat sources, flammable gas leakage and places with smoke.

unit:mm

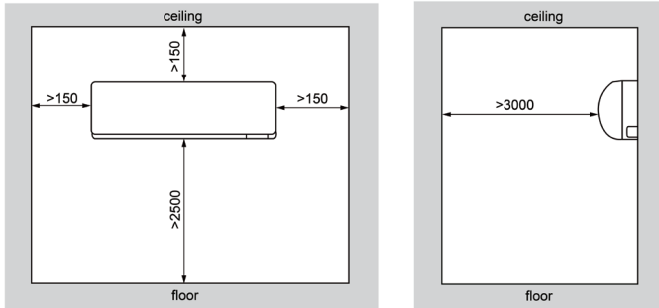

2.2 Outline Dimensions

unit:mm

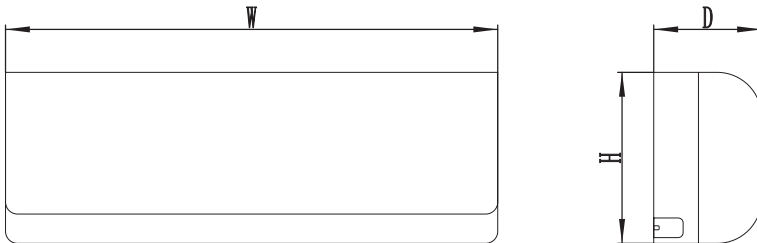

Model	W	H	D	Water inlet and outlet pipe (outer diameter)	Drain pipe (outer diameter)
AFCD-23WM/2P	810	260	190	φ 12mm	φ 17mm
AFCD-28WM/2P AFCD-40WM/2P	867	276	206		
AFCD-23WM/2P, AFCD-53WM/2P, AFCD-60WM/2P	978	333	248		
AFCD-75WM/2P	1116	333	248		
AFCD-85WM/2P	1350	333	253		

2.3 Installation of the Rear Panel

- (1) Since the drain pipe is on the left side, it is necessary to adjust the rear panel to make the left side slightly inclined downward, which is conducive to the drainage of condensate.
- (2) Drill fixing holes on the wall according to the figure, then fix the rear panel on the wall with expansion nails, and check the firmness by pulling the rear panel. The rear panel should support the weight of an adult (about 60kg), and each bolt should bear the weight evenly. If there is looseness, more expansion nails are necessary.

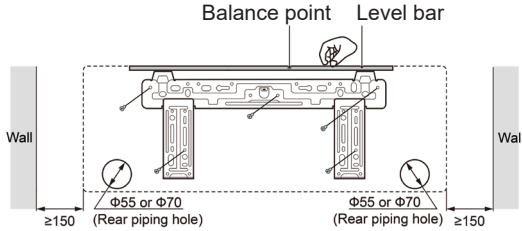

2.4 Piping Holes for Installation

- (1) Make the piping hole (Φ55 or 70mm) in the wall at a slight downward slant to the outdoor side.
- (2) Insert the piping-hole sleeve into the hole to prevent the connection piping from being damaged when passing through the hole.

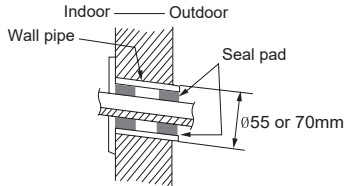

2.5 Piping and Wiring

When the unit is wired from the left, cut off the left knockout hole; when the unit is wired from the right, cut off the right knockout hole. For piping, wrap the pipes with adhesive tape to protect the pipes and insulation.

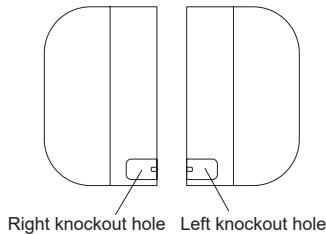

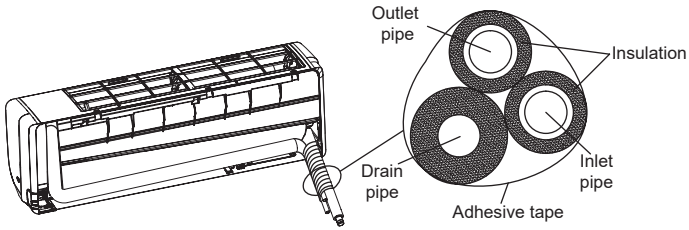

2.6 Installation of the Drain Pipe

- (1) For smooth draining, the drain hose should be placed at a downward slant.
- (2) Do not wrench or bend the drain hose or flood its end by water.
- (3) When the long drainage hose passing through indoor, should wrap the insulation materials.
- (4) Do not connect the drain pipe to the waste water pipe or other pipes that may produce corrosive or abnormal smell to prevent the smell from entering the room or damaging the unit.
- (5) It is not allowed to connect the drain pipe to the rainwater pipe to prevent property damage or personal injury caused by the influx of rainwater.
- (6) The drain pipe shall be connected to the special drainage system for the air conditioning system.

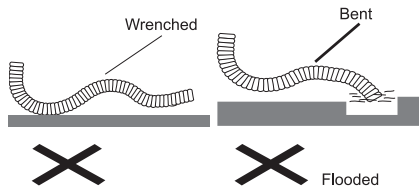

2.7 Installation of the the Inlet and Outlet Pipe

- (1) Install the nut, spring washer, gasket and sealing ring on the inlet/outlet pipe and the chilled water supply/return pipe in turn;
- (2) Align the center of the inlet/outlet pipe with the center of the chilled water supply/return pipe, insert both ends of the connecting nut respectively, and the insertion depth is about 6-7mm,
- (3) The connecting pipe shall not be bent and deformed, and the pipe shall be fixed firmly after connection, otherwise there will be hidden danger of water leakage;
- (4) Tighten the nuts with a spanner, and check for water leakage after water supply;
- (5) The pipeline must be wrapped with insulating material to prevent condensate from dripping and damaging the interior decoration.

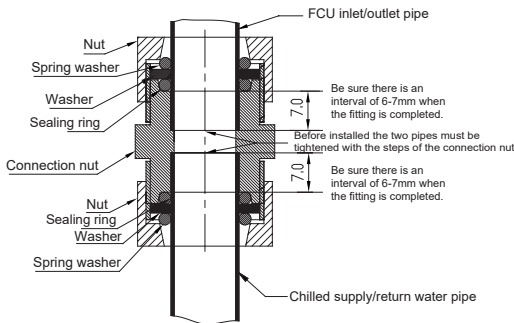
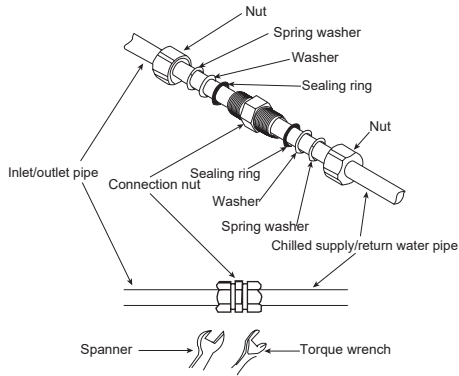

2.8 Installation of the Water Damper

NOTE

- The unit must be equipped with a electric water valve, otherwise the unit will have the risk of condensation and flooding, or there would be energy loss under the OFF state.
- The installation of the water valve must be carried out according to the following requirements.

⊘ It is not allowed to directly insulate the connection line of the actuator and the water pipe together, otherwise it would lead to shortcutting of the water valve which would affect its service life.

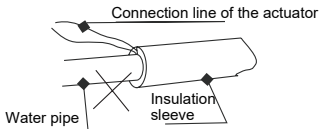

⚠ Put the connection line through the PVC pipe and then bind them with the insulation sleeve.

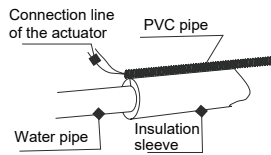

⊘ Never install the valve downwards, otherwise the condensate would flow into the valve and damage the valve or then would lead to shortcutting or fire hazards.

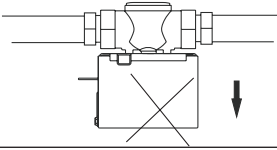

⚠ The main body of the valve should be installed upwards and the power lines should be arranged above the water pipe.

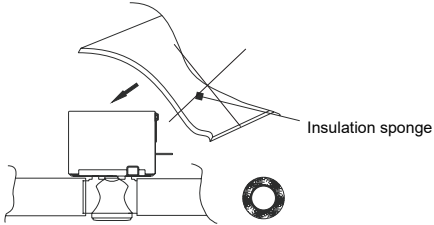
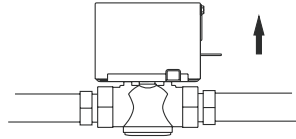

Do not cover fully the valve with the insulation sponge; otherwise it would lead to poor heat radiation and even fire hazards.

2.9 Electric Wiring

2.9.1 Precautions

- (1) Electrical installation must meet local electrical safety regulations and must be carried out by professionals;
- (2) Special power must be used for electrical installation, and circuit breakers with sufficient capacity must be installed for protection. A circuit breaker must be installed in the fixed circuit, all its poles shall be open and the contact gap shall be at least 3mm. The type of circuit breaker recommended for the models involved in this manual is two-pole 6A, and the wire diameter of the recommended power cord is $3 \times 1.0 \text{ mm}^2$.
- (3) Don't pull the power cable with too much force.
- (4) The size of the power cable should be large enough. If there is damage to the power cable or connecting cable, it should be replaced by a dedicated cable.
- (5) The unit should be reliably grounded, the yellow-green double-color line is the grounding line, and the grounding line is prohibited for other purposes.
- (6) The grounding line shall be fixed with special fastening screws, otherwise it will cause grounding failure and even electric shock.
- (7) The grounding line cannot be connected to water pipes, gas pipes, drainage pipe and other places that are proved to be unsafe by professionals.
- (8) The minimum distance between the unit and the combustible material is 1.5m.

2.9.2 Wiring Steps

⚠ WARNING

Before electrical installation of the connecting cable, power supply must be cut off first, and the power cannot be connected until all installation work has been completed.

NOTE

- Open the electric box cover, let the power lines of the main unit and water valve, communication cable and other connecting lines go through from the rear case to the electric box terminal board;
- Do wiring according to the circuit diagram on the unit. The cable connection must be accurate, firm and reliable;
- After connecting the cable, be sure to fix the cable firmly with wire clamps;
- Cables can not be pulled by itself or other external forces;
- Metal filing, excessive thread ends and clamps generated during installation shall be removed from the main unit;
- Power cables and communication cables can not be intertwined but separated, otherwise the unit communication may be affected;
- After installation, check the tightening degree of all bolts again and the accuracy of cable connection;
- After installation and the power-on test run have been completed, put the electric box cover back.
- It is recommended that the cable should be sized not less than 3x1 mm².

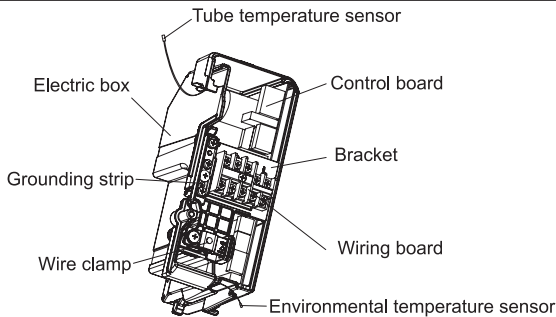

WARNING

There may be differences between the electrical box and the actual one, and the actual one shall prevail.

2.9.3 Wiring Guidance for Reserved Connecting Lines

The unit reserves the connection lines for the wired controller, the group-control system and the remote monitoring system, which are equipped with terminals. If the customer needs these function, follow instructions stated below for wiring:

Step 1: cut off the end of the reserved line with scissors;

Step 2: peel off the cable insulation with the cable peeler to expose about 10mm long copper wire;

Step 3: insert the reserved cable and the customer cable into the terminal, press it with crimping pliers, and then wrap the terminal and the cable with insulating tape.

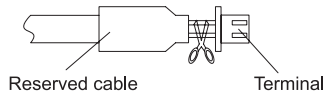

Step 1

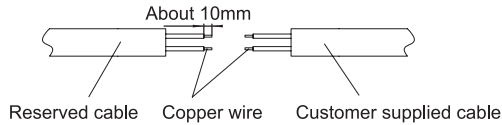

Step 2

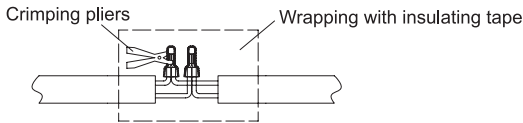

Step 3

2.9.4 Wiring Guidance for Group Control

One or more units can be controlled through one or two wired controller at the same time. The controlled units shall be of the same series and in the same network. The number of controlled units cannot exceed 16, and each unit shall be set to different addresses. If two wired controller are used, they shall also be set to different addresses. For the specific setting method, please refer to relevant instructions for the wired controller.

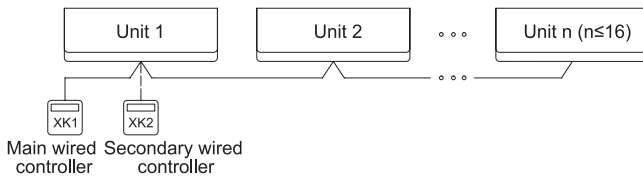

2.9.5 Wiring Guidance for the Remote Monitoring System

Remote monitoring is available for this series units. For this function, each unit needs to be set to different addresses through the wired controller. For the specific setting method, please refer to relevant instructions for the wired controller.

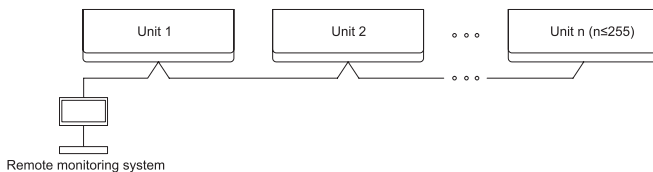

2.9.6 Wiring Guidance for the Access Control System

Access control is available for this series units, which can control the unit through access control.

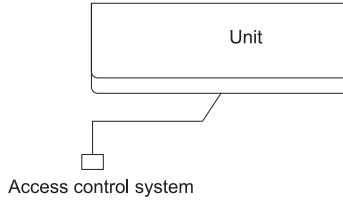

2.9.7 Guides for the DIP Setting

The control board is equipped with a 2-digit DIP switch, and its setting description is as follows (the black block represents a setting lever, and the actual object shall prevail)

- (1) Lever at 1: when the return air temperature reaches the set temperature, the fan will not stop;
- (2) Lever at ON: when the return air temperature reaches the set temperature, the fan stops;
- (3) Lever at 2: when the water temperature is too high for cooling or is too low for heating, the fan will run at low speed after stopping for 3 minutes;
- (4) Lever at ON: the water temperature is too high for cooling or is too low for heating, and the fan does not run;

NOTE

This function can also be set by the wired controller. When set by the wired controller, the DIP setting will be invalid, but only be done by the wired controller. Therefore, if it is not necessary, do not set this function by the wired controller.

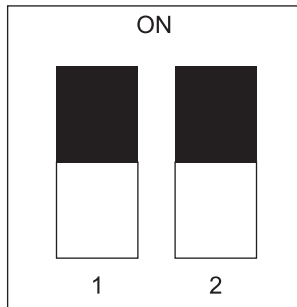

2.9.8 Guides for WIFI

WIFI is optional and requires to configure the WiFi module. (If the unit you purchased is configured with the WiFi Module, you do not need to purchase it again).

WIFI reset: when the remote controller is in the OFF state, press the MODE key and the TURBO key for 10 seconds at the same time, and the LED board will display the "OC" code, indicating that the reset is successful. At this time, the network can be matched through the mobile phone. If HF code is displayed during reset, it indicates WIFI communication failed.

For units with WIFI functions, please refer to App Operation Manual for more details.

NOTE

WIFI reset will erase personal information stored in the WiFi module, such as WIFI SSID and WIFI password.

2.9.9 Electric Wiring Diagrams

(1) AFCD-23WM/2P

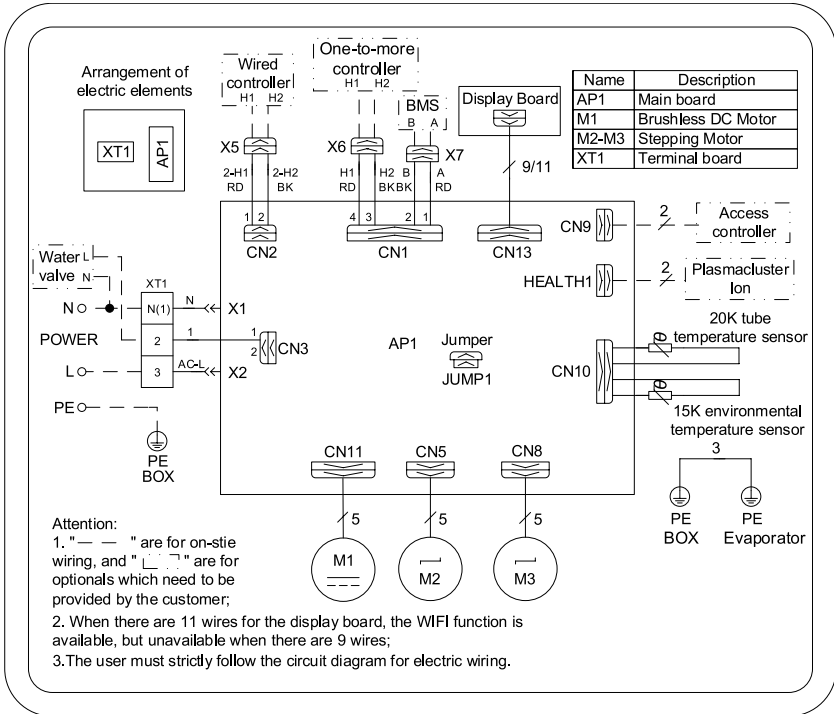

(2) AFCD-28WM/2P, AFCD-40WM/2P, AFCD-45WM/2P, AFCD-53WM/2P, AFCD-60WM/2P/, AFCD-75WM/2P

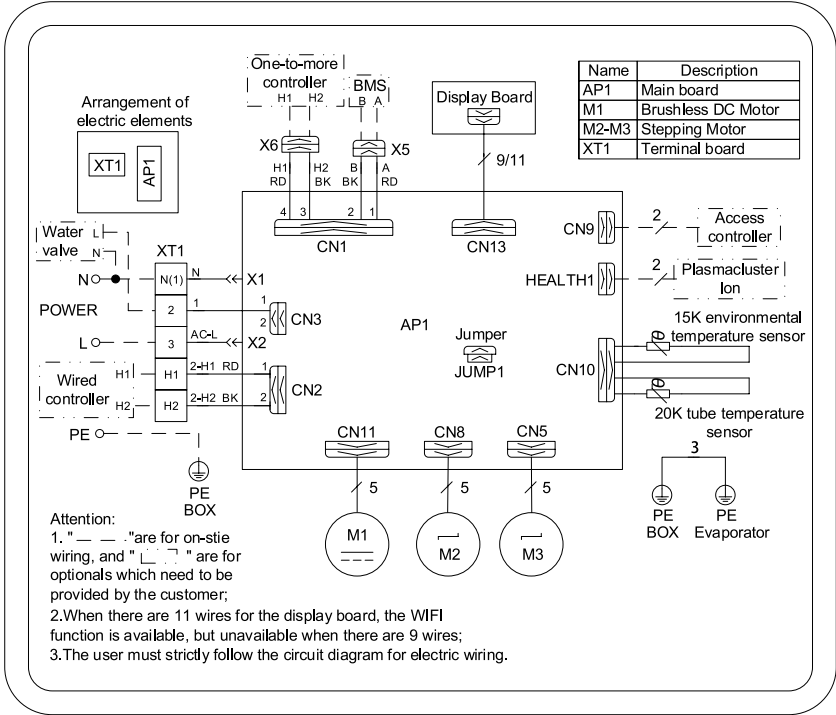

(3) AFCD-85WM/2P

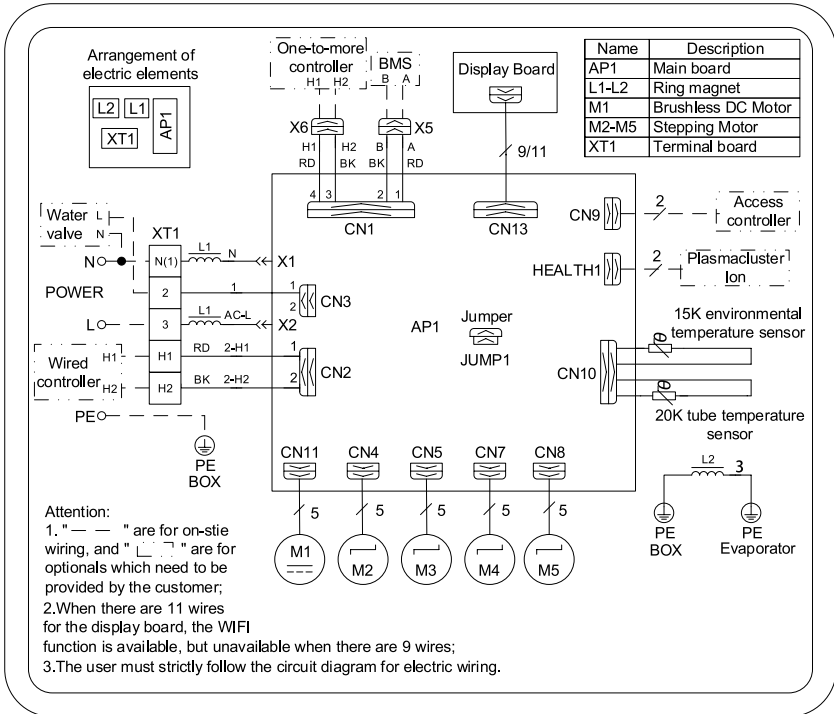

WARNING

There may be differences between the circuit diagram and the actual, the specific diagram at the unit shall always prevail.

Plasmacluster Ion function is not configured, so please contact the after-sales if there is a need.

2.9.10 Other Guidances

Fuse specification: T5AH 250V

The environmental temperature sensor and pipeline temperature sensor only collect the ambient temperature and pipeline temperature and are not used for other purposes.

3. Commissioning and Maintenance

3.1 Inspection after Installation

Items to be checked	Possible malfunction
Has it been fixed firmly?	The unit may drop, shake or emit noise.
Have you done the water leakage test?	It may cause condensation and dripping.
Is heat insulation sufficient?	It may cause condensation and dripping.

Items to be checked	Possible malfunction
Is water drainage well?	It may cause condensation and dripping.
Is the voltage in accordance with the rated voltage marked on the nameplate?	It may cause electric malfunction or damage the part.
Is the electric wiring and piping connection installed correctly and securely?	It may cause electric malfunction or damage the part.
Has the unit been connected to a secure earth connection?	It may cause electrical leakage.
Is the power cord specified?	It may cause electric malfunction or damage the part.
Is the inlet and outlet been covered?	It may cause insufficient cooling(heating)capacity.

3.2 Trial Operation

3.2.1 Before Trial Operation

- (1) Do not switch on power before installation is finished completely.
- (2) Electric wiring must be connected correctly and securely.
- (3) All the impurities such as scraps and thrums must be cleared from the unit.

3.2.2 Trial Operation Steps

- (1) When the unit is powered on, press the TURBO button of the remote controller 3 times continuously within 5 seconds, and then unit will enter the commissioning mode.
- (2) Select each operation mode to check whether it is operating normally.
- (3) If the test goes normally, press ON/OFF the turn off the unit.

3.3 Air Exhaust

⚠ NOTE

The air relief valve is located at the air return grille of the upper end of the unit. Do not adjust the air relief valve with great force when exhausting air. Otherwise, there is a risk of water leakage due to damaged air relief valve.

If air needs to be exhausted, perform the following steps.

- (1) Open the panel and remove the filter at the right side;
- (2) Use a straight screwdriver to adjust the air relief valve, and turn the valve plug counterclockwise for 3-4 turns;
- (3) Start the fan coil unit and let it perform cooling on or heating;
- (4) When there is water from the air relief valve, turn the plug clockwise to tighten it.
- (5) Reinstall the filter and panel to complete the air exhaust.

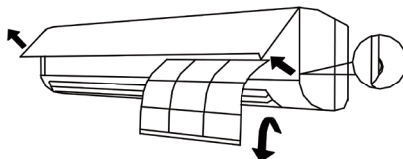

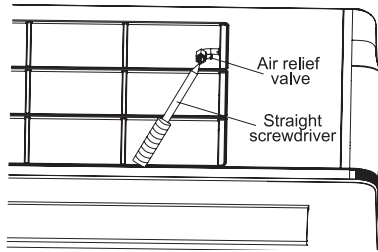

⚠ WARNING

As shown in the figure below, it is forbidden to use a straight screwdriver to press the air relief valve hard, just put it into the slot of the valve and rotate it counterclockwise, otherwise there is a risk of damaging the valve or even water leakage.

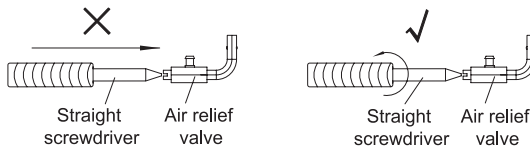

3.4 Maintenance Method

3.4.1 Cleaning Panel

⚠ NOTE

Do take down it before cleaning.

- (1) Pull along the direction of arrows to take down the panel.
- (2) Clean the panel.

Clean it with a soft-hair brush, water and neutral cleaning fluid, and then dry it.

⚠ NOTE

Do not use water above 45°C to wash the panel to prevent decoloration or deformation. Install the panel.

As shown in the figure below, install the stands of both ends of the panel into the slot and put the middle rotating shaft into the groove, then place the panel and clasp back along the arrow direction.

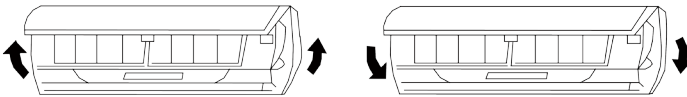

3.4.2 Cleaning the Air Filters

Clean it once every 3 months; when the usage environment has lots of dust, it should be cleaned more frequently.

- (1) Take down the air filter.

As shown in Fig. 7.2, open the surface panel by holding the both ends of groove along the arrow direction, and then take the air filter out downward.

- (2) Clean the filter.

Use cleaner or water to wash the filter; if the filter is too dirty (like oil stain on it), warm water (lower than 45°C) with neutral detergent can be used, then dry it in the shade.

NOTE

Do not clean the filter by hot water higher than 45°C for preventing fade or deformation.
Do not burn it on fire or the filter would catch fire or deformation.

(3) Install air filter

Install the air filter properly along the arrow direction, making the side marked "Front" facing yourself and then place the panel back.

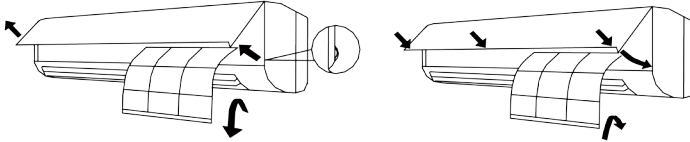

4. Troubleshooting

WARNING

The unit is not expected to be serviced by users. Incorrect repair may cause electric shock or fire, so please contact an authorized service center for professional service. The following checks prior to contact may save your time and money.

4.1 Error List

- (1) Check if there is blockage in the inlet or outlet vent of the fan coil unit.
- (2) Check if the earth wire is earthed reliably.
- (3) Check if the batteries in the wireless remote controller have been replaced.
- (4) Check if the air filter has been installed properly In order to start up the fan coil unit smoothly after it has been turned off for a long time period, energize the unit 8 hours before turning it on.

4.2 Check after the Usage Season

- (1) Clean filter and body of the fan coil unit
- (2) Cut off the main power supply of the fan coil unit.

4.3 Troubleshooting

Phenomenon	Troubleshooting
<p>The unit does not operate:</p>	<ul style="list-style-type: none"> • Blow of fuse or breaker • Power cut • Don't connect with power • Low batteries of wireless remote controller • Wireless remote controller exceed remote control area
<p>Odours are emitted:</p>	<ul style="list-style-type: none"> • Some odours may be emitted from the FCU. This is the result of room smells (such as furniture, tobacco, ect.) which have been taken into the FCU. • Consult authorized service center for cleaning if the odours still exist.

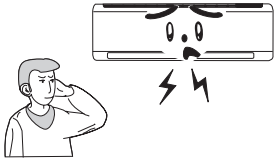
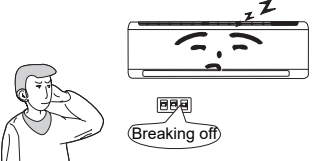
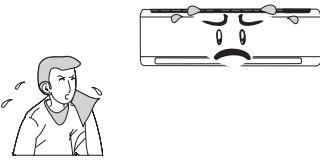
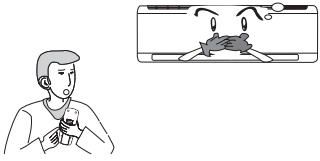
Phenomenon	Troubleshooting
<p>Mist is emitted in COOL mode</p> 	<p>During cooling operation, a thin mist may be seen emitted from the FCU due to high room temperature and humidity. After a period of time, the mist will disappear with the decrease of room temperature and humidity.</p>
<p>Cracking noise:</p> 	<ul style="list-style-type: none"> • This is the sound of friction caused by expansion and/or contraction of panel or other parts due to the change of temperature.
<p>The unit can not be started up:</p> 	<ul style="list-style-type: none"> • Is the power cut off? • Is the power plug loose? (If applicable) • Is the circuit protection device tripped off? • Is voltage higher or lower? (Tested by professionals) • Is the TIMER correctly used?
<p>Cooling/Heating effect is poor:</p> 	<ul style="list-style-type: none"> • Is temperature setting appropriate? • Is the inlet or outlet blocked? • Is the filter dirty? • Is the window or the door open? • Is low fan speed set? • Are there heat sources in the room?
<p>Remote controller is not available:</p> 	<ul style="list-style-type: none"> • Check if there is magnetic or electrical interference near the unit that may affecting operation of the controller. In this case, pull the plug out and reinsert it. • Is the remote controller within its operating range or obstructed? Check the condition of the batteries and replace them if necessary. • Check if the remote controller is damaged.
<p>Water leakage of FCU.</p>	<ul style="list-style-type: none"> • The humidity is high. • Condensate overflows. • Drain hose is loose.
<p>Noise from FCU.</p>	<p>The noise emitted when the fan is switching on or off.</p>
<p>FCU can not blow air:</p>	<ul style="list-style-type: none"> • In HEAT mode, when the temperature of FCU heat exchanger is very low, air flow is stopped in order to prevent cold air. • In COOL mode, when the temperature of FCU heat exchanger is very high, air flow is stopped in order to prevent hot air.

Phenomenon	Troubleshooting
Moisture on air outlet :	If the unit operates at high humidity for a long time, moisture will be generated on the air outlet grill and then drip off.

4.4 Error Codes

Error code	Error description	Unit status	Troubleshooting
F0	FCU ambient temperature sensor error	Normal operation, ambient cannot be detected.	1. Is the temperature sensor connected abnormally or damaged? 2. Contact the after-sales.
F5	Wired controller temperature sensor error	Normal operation, ambient cannot be detected.	1. Is the temperature sensor connected correctly or damaged? 2. Contact the after-sales.
F1	Tube temperature sensor error	Normal operation, pipeline temperature cannot be detected.	1. Is the temperature sensor connected abnormally or damaged? 2. Contact the after-sales.
E8	DC motor stall protection	Shutdown	1. Is the motor connected abnormally or damaged? 2. Check whether the fan is stuck by foreign objects. 3. Contact the after-sales.
C5	Jumper error	Shutdown	1. Is the jumper connected abnormally or damaged? 2. Contact the after-sales.
E6	Communication error	Shutdown	1. Is the communication equipment connected abnormally or damaged? 2. Is the communication cable connected abnormally? 3. Contact the after-sales.
HF	WiFi module communication error	Normal operation, WIFI disabled	1. Is WiFi connected abnormally or damaged? 2. Is the network abnormal? 3. Contact the after-sales.

4.5 Service Center

When the following phenomena appeared, please stop operating immediately, cut off the main power supply of the unit and then contact the service center of the fan coil unit.

- (1) Harsh sound heard when running.
- (2) The fuse or protector opened frequently.
- (3) Substance or water pulled in the unit involuntarily.
- (4) Water leakage in room.
- (5) Power cord overheated.
- (6) Abnormal odor is given out when running.

Part Two: Remote Controller YAP1F

NOTE

The remote controller comes standard for the air conditioner and is used to operate the fan coil unit.

When the remote controller operates the fan coil unit, the fan coil unit shall be within the receiving range, and the remote controller shall point to the signal receiving window of the fan coil unit to improve the receiving sensitivity of the the fan coil unit.

After power-on, the the fan coil unit will make a sound and the power indicator will light up. After that, you can use the remote controller to operate the the fan coil unit.

When the remote controller sends a signal, the icon  will flash for 1 second. When the the fan coil unit receives a valid remote control signal, it will emit a "ding" sound, indicating that the signal has been sent to the fan coil unit.

For functions that the fan coil unit does not have, if you press the corresponding button on the remote controller, the fan coil unit will maintain the original operating state.





Do not use old or different types of batteries for the remote controller, otherwise, it may cause malfunctions.

When you do not use the remote controller for a long time, please take out the batteries.

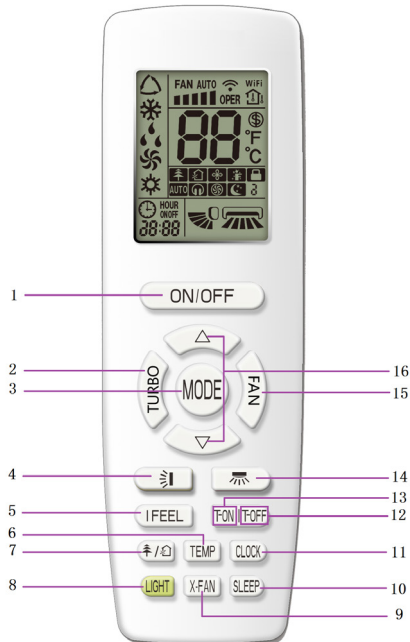
1. Remote Controller YAP1F

1.1 Button Name and Function Introduction



No.	Button name	Function
1	ON/OFF	Turn on or turn off the unit
2	TURBO	Set turbo function
3	MODE	Set operation mode
4		Set up&down swing status
5	I FEEL	Set I FEEL function
6	TEMP	Switch temperature displaying type on the unit's display
7		Set health function and air function
8	LIGHT	Set light function
9	X-FAN	Set X-FAN function
10	SLEEP	Set sleep function
11	CLOCK	Set clock of the system
12	T-OFF	Set timer off function
13	T-ON	Set timer on function
14		Set left&right swing status
15	FAN	Set fan speed
16		Set temperature and time

2. ON/OFF

Press "ON/OFF" to start/stop the main unit to be controlled.



3. Selecting Operation Mode

In unit on status, press MODE button to select operation mode in following sequence:



Note: the automatic operation mode is unavailable. In this mode, it will operate as the original operation mode.

4. Setting Temperature



In unit on status, press  button to increase setting temperature and press  button to decrease setting temperature. The range of temperature is from 16°C to 30°C .

5. Adjusting Fan Speed

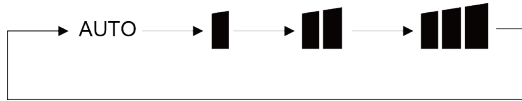
In unit on status, press FAN button to adjust fan speed in following sequence:



6. Setting Turbo Function

- (1) Under cool or heat mode, press TURBO button to set turbo function.
- (2) When  is displayed, turbo function is on.
- (3) When  is not displayed, turbo function is off.
- (4) When turbo function is on, the unit operates in super high speed to achieve quick cooling or heating.
When turbo function is off, the unit operates in setting fan speed.



7. Setting Swing Function

- (1) Setting left&right swing

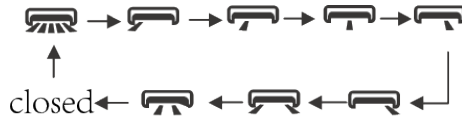
- Under simple swing status, press  button to adjust left&right swing status;
- Under fixed-angle swing status, press  button to adjust left&right swing angle circularly as below:



NOTE

- Operate continuously left&right swing in 2 seconds, swing states will change according to above-mentioned order, or switch closed state and  state.
- As functions of  and  are unavailable, the remote controller will keep the current operation.

- (2) Setting up&down swing

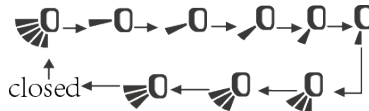

- Under simple swing status, press  button to adjust up&down swing status;
- Under fixed-angle swing status, press  button to adjust up&down swing angle circularly as below:



NOTE

- Operate continuously left&right swing in 2 seconds, swing states will change according to above-mentioned order, or switch closed state and  state;



8. Viewing Ambient Temperature

- (1) In unit on status, receiver light board or wired controller is defaulted to display setting temperature.
Press TEMP button to view indoor or outdoor ambient temperature.
- (2) When  is displayed, it means the displayed temperature is setting temperature.
- (3) When  is displayed, it means the displayed temperature is indoor ambient temperature.
- (4) When  is displayed, it means the displayed temperature is outdoor ambient temperature.

NOTE

- Setting temperature is always displayed in Remote Controller.
- As The function of checking the outdoor ambient temperature is unavailable, the remote controller will keep the current operation.

9. Setting Health Function

- (1) In unit on status, press  button to set health function.
- (2) When  is displayed, health function is on.
- (3) When  is not displayed, health function is off.
- (4) Health function is available when the unit is equipped with anion generator. When health function is on, the anion generator will start operation, adsorbing the dusts and killing the bacteria in the room.

10. Setting Clock

Press this button to set clock time. "⌚" icon on remote controller will blink. Press "▲" or "▼" button within 5s to set clock time. Each pressing of "▲" or "▼" button, clock time will increase or decrease 1 min. If hold "▲" or "▼" button, 2s later, time will change quickly. Release this button when reaching your required time. Press "CLOCK" button

NOTE

- Clock time adopts 24-hour mode.
- The interval between two operations can't exceed 5s. Otherwise, remote controller will quit setting status.



11. Setting Timer

You can set the operation time of unit as you need. You can also set timer on and timer off in combination.



Before setting, check if the time of the system is the same as the current time. If not, please set the time according to current time.

- (1) Setting timer off
 - Pressing TOFF button, "OFF" is blinking and time displaying zone displays the timer time of last setting.
 - Press ▲ or ▼ button to adjust the timer time.
 - Press TOFF button again to confirm setting. OFF is displayed and time displaying zone resumes to display current time.
 - Press TOFF button again to cancel timer and OFF is not displayed.
- (2) Setting timer on
 - Pressing TON button, "ON" is blinking and time displaying zone displays the timer time of last setting.
 - Press ▲ or ▼ button to adjust the timer time.
 - Press TON button again to confirm setting. ON is displayed and time displaying zone resumes to display current time.
 - Press TON button again to cancel timer and ON is not displayed.

12. Setting Sleep Function

- (1) In unit on status, press SLEEP button to turn on or turn off sleep function.
- (2) When  is displayed, sleep function is on.
- (3) When  is not displayed, sleep function is off.







13. Setting X-FAN Function

- (1) In cool or dry mode, press X-FAN button to set X-FAN function.
- (2) When  is displayed, X-FAN function is on.
- (3) When  is not displayed, X-FAN function is off.
- (4) When X-FAN function is on, the water on the evaporator will be blown away until turning off the unit to avoid mildew.

14. Setting Light Function

The light on the receiver light board will display present operation status. If you want to turn off the light, please press LIGHT button. Press this button again to turn on the light.

15. Setting Child Lock

- (1) Press  and  button simultaneously to lock the buttons on remote controller and  is displayed.
- (2) Press  and  button simultaneously again to unlock the buttons on remote controller and is not displayed.
- (3) If the buttons are locked,  blinks 3 times when pressing the button and any operation on the button is invalid.

16. Switching Temperature Scale

In unit off status, press MODE button and  button simultaneously to switch temperature scale between °C and °F .

17. Resetting WiFi

Under the OFF state, press the "TURBO" and "MODE" buttons at the same time for about 10s, and the remote controller sends a WIFI reset signal to the fan coil unit. The fan coil unit will ring to indicate that the unit has received the signal. At this time, the WiFi module will restore the default settings.

18. Replacing Batteries

- (1) Lift the cover along the direction of arrow (as shown in Fig 1 ①).
- (2) Take out the original batteries (as shown in Fig 1 ②).
- (3) Place two 7# (AAA 1.5V) dry batteries, and make sure the position of "+" polar and "-" polar is correct (as shown in Fig 2 ③).
- (4) Reinstall the cover (as shown in Fig 2 ④).

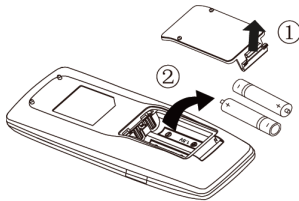

Fig.1

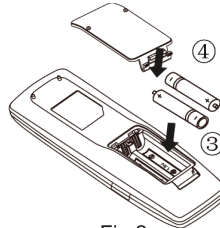

Fig.2



66139914873