



Owner's Manual

Original Instructions

Commercial Air Conditioners

AHU-KIT

Models:

GMV-N36U/C-T

GMV-N71U/C-T

GMV-N140U/C-T

GMV-N280U/C-T

GMV-N560U/C-T

Thank you for choosing commercial air conditioners. Please read this Owner's Manual carefully before operation and retain it for future reference.

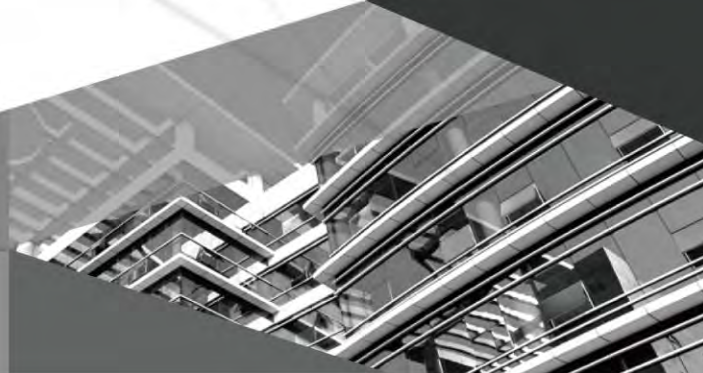

To Users

Thank you for selecting ASAMI's product. Please read this instruction manual carefully before installing and using the product, so as to master and correctly use the product. In order to guide you to correctly install and use our product and achieve expected operating effect, we hereby instruct as below:

- (1) This appliance is not intended for use by persons (including children) with reduced physical, sensory or mental capabilities, or lack of experience and knowledge, unless they have been given supervision or instruction concerning use of the appliance by a person responsible for their safety. Children should be supervised to ensure that they do not play with the appliance.
- (2) In order to ensure reliability of product, the product may consume some power under stand-by status for maintaining normal communication of system and preheating refrigerant and lubricant. If the product is not to be used for long, cut off the power supply; please energize and preheat the unit in advance before reusing it.
- (3) Please properly select the model according to actual using environment, otherwise it may impact the using convenience.
- (4) This product has gone through strict inspection and operational test before leaving the factory. In order to avoid damage due to improper disassembly and inspection, which may impact the normal operation of unit, please do not disassemble the unit by yourself. You can contact with the special maintenance center of our company if necessary.
- (5) When the product is faulted and cannot be operated, please contact with our maintenance center as soon as possible by providing the following information.
 - 1) Contents of nameplate of product (model, cooling/heating capacity, product No., ex-factory date).
 - 2) Malfunction status (specify the situations before and after the error occurs).
- (6) All the illustrations and information in the instruction manual are only for reference. In order to make the product better, we will continuously conduct improvement and innovation. We have the right to make necessary revision to the product from time to time due to the reason of sales or production, and reserve the right to revise the contents without further notice.
- (7) The final right to interpret for this instruction manual belongs to ASAMI.

Exception Clauses

Manufacturer will bear no responsibilities when personal injury or property loss is caused by the following reasons:

- (1) Damage the product due to improper use or misuse of the product;
- (2) Alter, change, maintain or use the product with other equipment without abiding by the instruction manual of manufacturer;
- (3) After verification, the defect of product is directly caused by corrosive gas;
- (4) After verification, defects are due to improper operation during transportation of product;
- (5) Operate, repair, maintain the unit without abiding by instruction manual or related regulations;
- (6) After verification, the problem or dispute is caused by the quality specification or performance of parts and components that produced by other manufacturers;
- (7) The damage is caused by natural calamities, bad using environment or force majeure.

Contents

1 Safety Notices (Please be sure to abide).....	1
2 Product	4
2.1 Names of Key Components	4
2.2 Overall System Connection Diagram.....	4
2.3 Standard Fittings	5
2.4 Specifications	6
2.5 Selecting the Air Handling Unit	8
3 Preparations for Installation.....	11
3.1 Before Installation.....	11
3.2 Location for Installation	12
3.3 Requirements for Communication Wire.....	13
3.4 Wiring Requirements.....	14
3.5 Piping Requirements	15
3.6 Capacity Setting	17
4 Product Installation	19
4.1 Unit Dimensions and Maintenance Space.....	19
4.2 EXV Installation	21
4.3 Piping Installation	23
4.4 Installation of the Control Box	24
4.5 Installation of the Temperature Sensors	26
4.6 Installation of the EXV Cable	29
4.7 Installation of Wired Controller	29
5 Wire Connection.....	29
5.1 Connect Cables and Terminals of WiringBoard	30
5.2 Power Cord Connection	31
5.3 Connection of Communication Wire between Indoor Unit and Outdoor Unit (or Indoor Unit)..	32
5.4 Connect Communication Wire of WiredController	32
5.5 Illuminate for Connection of Wired Controller and Indoor Units (AHU-KIT) Network.....	33
6 Function Setting	35
6.1 Statement on Linkage Function Setting	35
6.2 Fresh air Function Setting	35
6.3 Selection of Controller	36
7 Operation and Maintenance	40
7.1 Before Operation	40
7.2 Test Operation	41
7.3 Routine Maintenance	41
7.4 Disposal Requirements	41
8 Table of Error Codes for Indoor Unit.....	42
9 Troubleshooting	43

1 Safety Notices (Please be sure to abide)



Warning: If not abide strictly, it may cause severe damage to the unit or the people.



Note: If not abide strictly, it may cause slight or medium damage to the unit or the people.



This sign indicates that the operation must be prohibited. Improper operation may cause severe damage or death to people.



This sign indicates that the items must be observed. Improper operation may cause damage to people or property.



WARNING!

















This product can't be installed at corrosive, inflammable or explosive environment or the place with special requirements, such as kitchen. Otherwise, it will affect the normal operation or shorten the service life of the unit, or even cause fire hazard or serious injury. As for above special places, please adopt special air conditioner with anti-corrosive or anti-explosion function.





This Multi VRF System shall only be connected to an appliance suitable for the same refrigerant.

All units in Manual Cover is a partial unit, complying with partial unit of IEC 60335-2-40:2018, and must only be connected to other units that have been confirmed as complying to corresponding partial unit requirements of this international standard.

The electrical interface shall comply with electrical security requirement, voltage shall be 220-240V~50Hz or 208-230V~60Hz, current shall be referred to the table of "Dimension of power cord and capacity of air switch" in Section 3.4, and safety class of construction is I .

	<p>Please install the unit according to instructions in this manual. Read this manual carefully before starting up or checking the machine.</p>		<p>Installation should be performed by dealer or qualified technicians. Do not install the product by yourself. Improper installation may result in water leakage, electric shock or fire hazard.</p>
	<p>Make sure the local power supply is in accordance with units before installation, and check the power supply carefully.</p>		<p>This air conditioner must be properly grounded through the receptacle to avoid electric shock. The grounding wire shouldn't be connected with gas pipe, water pipe, lightning arrester or telephone line.</p>
	<p>Please use specialized accessories or parts to carry out installation, or water leakage, electric shock, fire hazard may result.</p>		<p>R410A refrigerant can produce poisonous gas once it meets fire, so please ventilate the room immediately if refrigerant leaks out during installation.</p>

 <p>Specialized</p>	<p>Diameter of power cord must be large enough. Damaged power cord and connecting wire must be replaced by specialized electric cable.</p>		<p>After the power cord is connected, please install the cover of electric box to avoid danger.</p>
 <p>N₂</p>	<p>Nitrogen must be charged according to technical requirements.</p>		<p>Short circuit is forbidden. Do not cancel the pressure switch in case the unit may be damaged.</p>
	<p>For units with wired controller, do not connect power supply until the wired controller is well installed. Otherwise, the wired controller cannot be used.</p>		<p>When the installation is finished, please check and make sure the drain pipe, pipeline and electric wire are all well connected in order to avoid water leakage, refrigerant leakage, electric shock or fire hazard.</p>
	<p>Do not extend fingers or objects into air outlet or air return grille.</p>		<p>If you use gas heater or petroleum heater in the same room, please open the door or window to maintain good air circulation in case the room may lack of oxygen.</p>
	<p>Never start or stop the air conditioner by inserting or removing the power cord.</p>	 <p>< 5Min</p>	<p>Do not turn off the air conditioner until it runs for at least 5 minutes. Otherwise, oil-return of the compressor will be affected.</p>
	<p>Children are not allowed to operate the air conditioner.</p>		<p>Do not operate the air conditioner with wet hands.</p>
	<p>Please turn the unit off and unplug your air conditioner before cleaning. Otherwise, it may cause electric shock or personal injury.</p>		<p>Do not spray water on the air conditioner or it will cause malfunction or electric shock.</p>
	<p>Do not expose the air conditioner directly to water or place it in a damp or corrosive environment.</p>	 <p>24H</p>	<p>Connect power supply 8 hours before operation. Do not disconnect power if you want to stop the unit in a short period of time, e.g. in one night (This is for protecting the compressor).</p>

	<p>Volatile liquid like thinner or gasoline will damage the appearance of air conditioner (Please use soft dry cloth and wet cloth with mild detergent to clean the outer case of air conditioner).</p>		<p>During Cooling mode, indoor temperature should not be set too low. Keep the difference between indoor temp and outdoor temp within 5°C .</p>
	<p>If abnormal condition occurs (e.g. unpleasant smell), please turn off the unit at once and disconnect power supply. Then contact ASAMI service center. If the air conditioner continues to operate despite of abnormal condition, the unit may be damaged and it may cause electric shock or fire hazard.)</p>		<p>Do not repair the air conditioner by yourself. Improper repair will cause electric shock or fire hazard. Please contact ASAMI service center and have it repaired by professional technicians.</p>
<p>This appliance can be used by children aged from 8 years and above and persons with reduced physical, sensory or mental capabilities or lack of experience and knowledge if they have been given supervision or instruction concerning use of the appliance in a safe way and understand the hazards involved. Children shall not play with the appliance. Cleaning and user maintenance shall not be made by children without supervision.</p> <p>Install units according to national wiring codes.</p> <p>If the supply cord is damaged, it must be replaced by the manufacturer or its service agent or a similarly qualified person in order to avoid a hazard.</p> <p>An all-pole disconnection device which has at least 3mm clearances in all poles, and disconnection must be incorporated in the fixed wiring in accordance with the wiring rules.</p>			
<p>ASAMI Electric Appliances, Inc. of Zhuhai will not assume responsibility for any personal injury or property loss caused by improper installation, improper debugging, unnecessary repair or not following the instructions of this manual.</p>			

Any personal injury or property loss caused by improper installation, improper debug, unnecessary repair or not following the instructions of this manual should not be the responsibility of ASAMI.

	<p>Correct Disposal of this product</p> <p>This marking indicates that this product should not be disposed with other household wastes throughout the EU. To prevent possible harm to the environment or human health from uncontrolled waste disposal, recycle it responsibly to promote the sustainable reuse of material resources. To return your used device, please use the return and collection systems or contact the retailer where the product was purchased. They can take this product for environmental safe recycling.</p>
---	---

2 Product

2.1 Names of Key Components

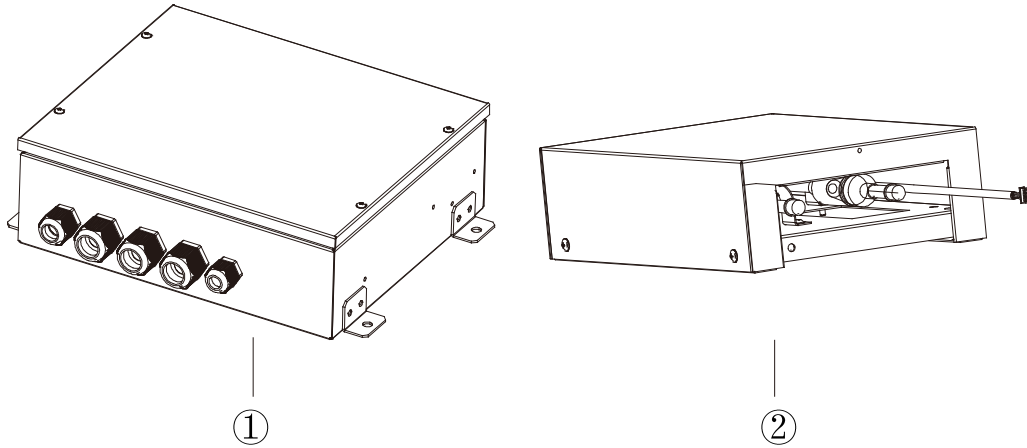

Figure 2-1

No.	①	②
Name	Control Box	EXV Box

2.2 Overall System Connection Diagram

When one AHU-KIT is connected to one AHU, the connection diagram is as follows:

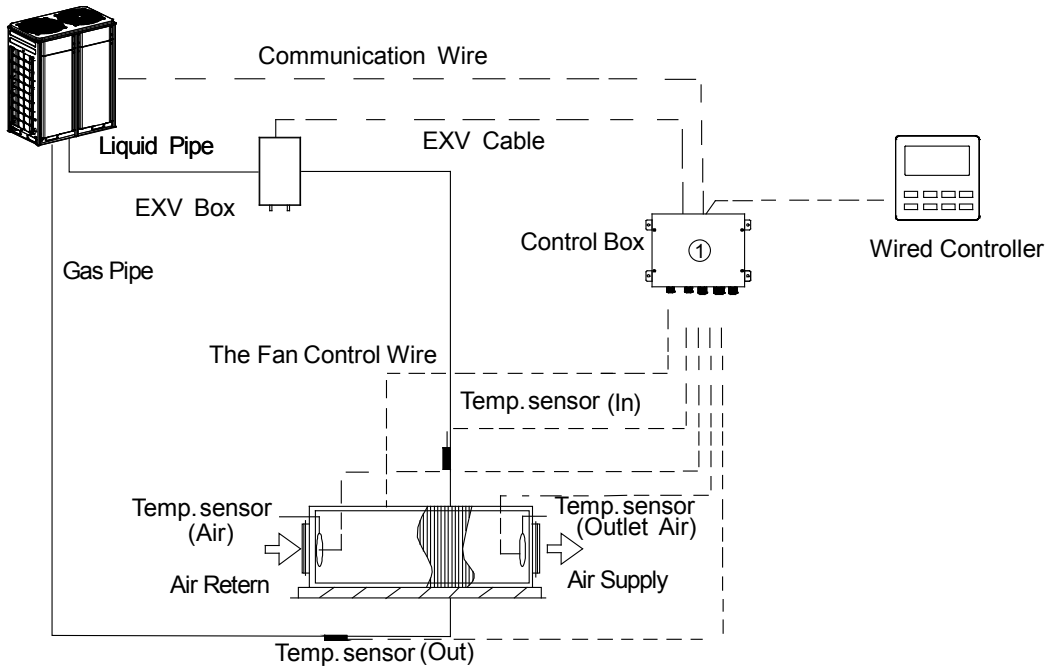
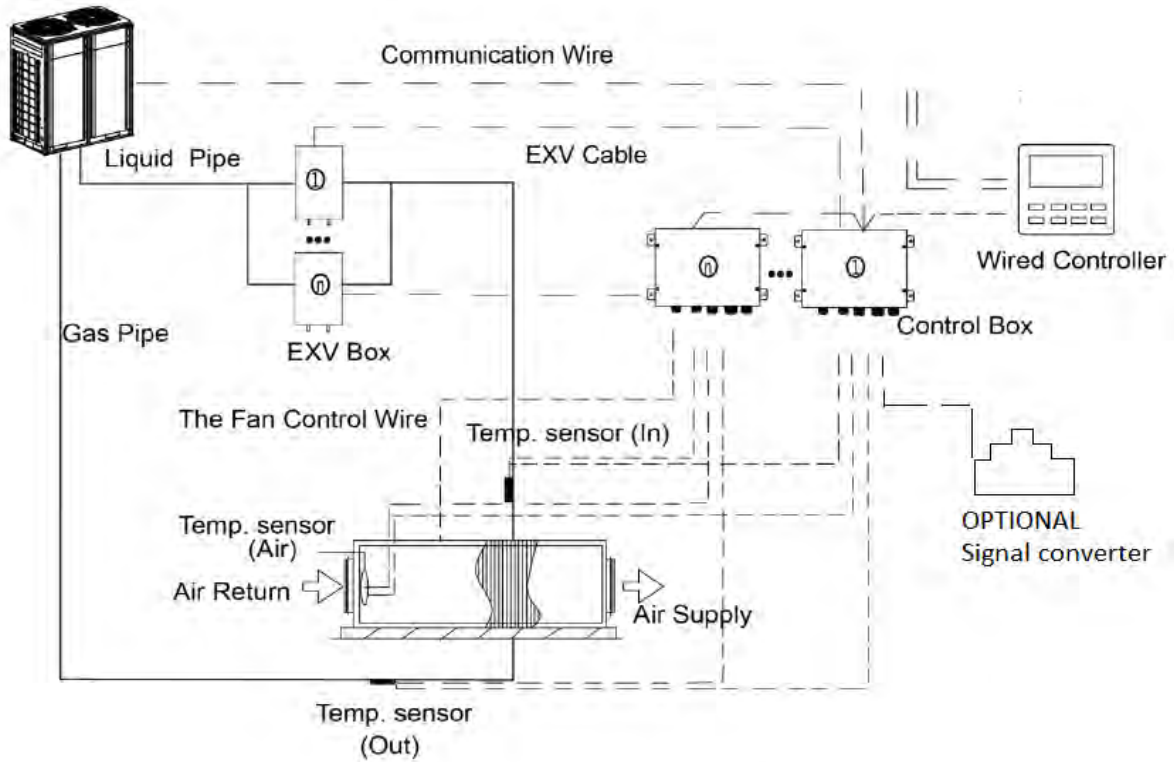









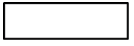

Figure 2-2

When several AHU-KITs ($n \leq 3$) are in parallel connection with one AHU, the connection diagram is as follows:



2.3 Standard Fittings

Please use the supplied standard fittings listed below as instructed.

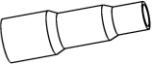
No.	Name	Appearance	Quantity
1	Magnetic ring		1or2
2	Swell screw		4
3	Self-tapping screw		4
4	Bundle		1
5	Operating Instruction Manual		1
6	Wired controller		1
7	Insulator		2
8	aluminum tape		2
9	rubber belt		2
10	Fastener		4
11	Reducer pipe (Only for 71, 280,560 type)		2

2.4 Specifications

Model			GMV-N36U/C-T			GMV-N71U/C-T			GMV-N140U/C-T		
Defaulted capacity of ex-factory	Capacity		36			71			140		
	Cooling	kW	3.6			7.1			14		
	Heating	kW	4			8			16		
Adjustable capacity	Capacity		28	36	45	56	71	90	112	140	
	Cooling	kW	2.8	3.6	4.5	5.6	7.1	9	11.2	14	
	Heating	kW	3.2	4	5	6.3	8	10	12.5	16	
Power input		W	8			8			8		
Power Supply		V/Ph/Hz	220-240/1/50 & 208-230/1/60			220-240/1/50 & 208-230/1/60			220-240/1/50 & 208-230/1/60		
Size of connection pipe	AHU-KIT (ex-factory pipe size)		mm	Φ6.35	Φ6.35	Φ9.52	Φ9.52	Φ9.52	Φ9.52	Φ9.52	Φ9.52
	Air handling unit	Liquid pipe	mm	Φ6.35	Φ6.35	Φ6.35	Φ9.52	Φ9.52	Φ9.52	Φ9.52	Φ9.52
		Gas pipe	mm	Φ9.52	Φ12.7	Φ12.7	Φ15.9	Φ15.9	Φ15.9	Φ15.9	Φ15.9
	Connection method		Brazing Connection			Brazing Connection			Brazing Connection		
Outline dimension (W×D×H)	EXV box	mm	203×326×85			203×326×85			203×326×85		
	Control box	mm	334×284×111			334×284×111			334×284×111		
Packing size (W×D×H)		mm	539×461×247			539×461×247			539×461×247		
Net weight		kg	10.0			10.5			10.5		

Model			GMV-N280U/C-T					GMV-N560U/C-T			
Defaulted capacity of ex-factory	Capacity		280					560			
	Cooling	kW	28					56			
	Heating	kW	31.5					63			
Adjustable capacity	Capacity		224	280	335	400	450	504	560	840	
	Cooling	kW	22.4	28	33.5	40	45	50.4	56	84	
	Heating	kW	25	31.5	37.5	45	50	56.5	63	94.5	
Power input		W	8					8			
Power Supply		V/Ph/Hz	220-240/1/50 & 208-230/1/60					220-240/1/50 & 208-230/1/60			
Size of connection pipe	AHU-KIT (ex-factory pipe size)		mm	Φ9.52	Φ9.52	Φ9.52	Φ9.52	Φ9.52	Φ15.9	Φ15.9	Φ15.9
	Air handling unit	Liquid pipe	mm	Φ9.52	Φ9.52	Φ12.7	Φ12.7	Φ12.7	Φ15.9	Φ15.9	Φ19.05
		Gas pipe	mm	Φ19.05	Φ22.2	Φ25.4	Φ25.4	Φ28.6	Φ28.6	Φ28.6	Φ31.8
	Connection method		Brazing Connection					Brazing Connection			
Outline dimension (W×D×H)	EXV box	mm	203×326×85					246×500×120			
	Control box	mm	334×284×111					334×284×111			
Packing size (W×D×H)		mm	539×461×247					759×645×180			
Net weight		kg	10.5					13.0			

Model(Combined)		GMV-N560U/C-T +GMV-N140U/C- T	GMV-N560U/C-T +GMV-N280U/C- T	GMV-N560U/C-T +GMV-N560U/C-T		
Capacity		840+140	840+280	840+560	840+840	
Cooling	kW	98	112	140	168	
Heating	kW	110.5	126	157.5	189	
Power input	W	8+8	8+8	8+8		
Power Supply	V/Ph/Hz	220-240/1/50 & 208-230/1/60	220-240/1/50 & 208-230/1/60	220-240/1/50 & 208-230/1/60		
Size of connection pipe	Air handling unit	Liquid pipe	Φ19.05	Φ19.05	Φ19.05	Φ19.05
		Gas pipe	Φ38.1	Φ38.1	Φ41.3	Φ41.3
Outline dimension (W×D×H)	EXV box	mm	246×500×120 +203×326×85	246×500×120 +203×326×85	(246×500×120)×2	
	Control box	mm	(334×284×111)×2	(334×284×111)×2	(334×284×111)×2	
Net weight	kg	13.0+10.5	13.0+10.5	13.0+13.0		

Model(Combined)		GMV-N560U/C-T +GMV-N560U/C-T +GMV-N140U/C-T	GMV-N560U/C-T +GMV-N560U/C-T +GMV-N280U/C-T	GMV-N560U/C-T +GMV-N560U/C-T +GMV-N560U/C-T		
Capacity		840+840+140	840+840+280	840+840 +560	840+840 +840	
Cooling	kW	182	196	224	252	
Heating	kW	204.5	220.5	252	283.5	
Power input	W	8+8+8	8+8+8	8+8+8		
Power Supply	V/Ph/Hz	220~240/1/50 & 208~230/1/60	220~240/1/50 & 208~230/1/60	220~240/1/50 & 208~230/1/60		
Size of connection pipe	Air handling unit	Liquid pipe	Φ19.05	Φ22.2	Φ22.2	Φ22.2
		Gas pipe	Φ41.3	Φ44.5	Φ44.5	Φ44.5
Outline dimension (W×D×H)	EXV box	mm	(246×500×120)×2 +203×326×85	(246×500×120)×2 +203×326×85	(246×500×120)×3	
	Control box	mm	(334×284×111)×3	(334×284×111)×3	(334×284×111)×3	
Net weight	kg	13.0+13.0+10.5	13.0+13.0+10.5	13.0+13.0+10.5		



Note:

The specifications of the unit is subject to change without prior notice due to improvement product. Please refer to the nameplate.

2.5 Selecting the Air Handling Unit

Select the air handling unit according to the technical data and limitations mentioned in the following table. Lifetime of the unit, operation range or operation reliability may be influenced if you neglect these limitations.

Model(Combined)	Capacity	Allowed Heat Exchanger Volume(dm ³)		Allowed Heat Exchanger Capacity(kW)				Suggested Air Flow (m ³ /h)	
	(kW)			Cooling		Heating			
		Min	Max	Min	Max	Min	Max	Min	Max
GMV-N36U/C-T	2.8	0.67	0.75	2.5	2.8	2.8	3.2	375	532
	3.6	0.75	0.96	2.8	3.6	3.2	4	420	684
GMV-N71U/C-T	4.5	0.96	1.2	3.6	4.5	4	5	540	855
	5.6	1.2	1.5	4.5	5.6	5	6.3	675	1064
	7.1	1.5	1.9	5.6	7.1	6.3	8	840	1349
GMV-N140U/C-T	9	1.9	2.4	7.1	9	8	10	1065	1710
	11.2	2.4	2.99	9	11.2	10	12.5	1350	2128
	14	2.99	3.74	11.2	14	12.5	16	1680	2660
GMV-N280U/C-T	22.4	3.74	5.98	14	22.4	16	25	2100	4256
	28	5.98	7.48	22.4	28	25	31.5	3360	5320
	33.5	7.48	8.94	28	33.5	31.5	37.5	4200	6365
	40	8.94	10.68	33.5	40	37.5	45	5025	7600
	45	10.68	12.02	40	45	45	50	6000	8550
GMV-N560U/C-T	50.4	12.02	13.46	45	50.4	50	56.5	6750	9576
	56	13.46	14.95	50.4	56	56.5	63	7560	10640
	84	14.95	22.43	56	84	63	94.5	8400	15960
GMV-N560U/C-T +GMV-N140U/C-T	98	22.43	26.17	84	98	94.5	110.5	12600	18620
GMV-N560U/C-T +GMV-N280U/C-T	112	26.17	29.9	98	112	110.5	126	14700	21280
GMV-N560U/C-T +GMV-N560U/C-T	140	29.9	37.38	112	140	126	157.5	16800	26600
	168	37.38	44.86	140	168	157.5	189	21000	31920
GMV-N560U/C-T +GMV-N560U/C-T +GMV-N140U/C-T	182	44.86	48.59	168	182	189	204.5	25200	34580
GMV-N560U/C-T +GMV-N560U/C-T +GMV-N280U/C-T	196	48.59	52.33	182	196	204.5	220.5	27300	37240
GMV-N560U/C-T +GMV-N560U/C-T +GMV-N560U/C-T	224	52.33	59.81	196	224	220.5	252	29400	42560
	252	59.81	67.28	224	272	252	306	33600	51680

The capacity is obtained at these test conditions: superheat (SH) = 5°C and supercool (SC) = 3°C.
Cooling: Saturated evaporating temperature = 6°C, air return temperature is 27°C (DB)/19°C (WB).
Heating: Saturated condensing temperature = 46°C, air return temperature is 20°C (DB).
The heat exchanger of air handling unit is designed for R410A, and it's working pressure is 4.3MPa.
Quantity of rows of heat exchanger: no more than 4 rows.
The diameter of copper pipe of heat exchanger is no more than 12.7mm, 9.52mm is recommended.
Air inlet temperature range of heat exchanger: cooling: 16~35°C, heating: 10~27°C.



Note:

When the AHU-KIT is matched with AHU, they can connect with VRF outdoor unit as VRF indoor unit. The connection is limited by the outdoor unit. There are three kinds of connection method:

- (1) Connection method 1: one-to-one

The AHU-KIT as below can adopt one-to-one connection method with VRF outdoor unit. Total capacity of AHU-KIT should be 80%~110% of that of outdoor unit.

Model(Combined)	Capacity in application (kW)	Capacity DIP
GMV-N71U/C-T	7.1	71
GMV-N140U/C-T	9	90
	11.2	112
	14	140
GMV-N280U/C-T	22.4	224
	28	280
	33.5	335
	40	400
	45	450
GMV-N560U/C-T	50.4	504
	56	560
	84	840
GMV-N560U/C-T+GMV-N140U/C-T	98	840+140
GMV-N560U/C-T+GMV-N280U/C-T	112	840+280
GMV-N560U/C-T+GMV-N560U/C-T	140	840+560
	168	840+840
GMV-N560U/C-T+GMV-N560U/C-T+GMV-N140U/C-T	182	840+840+140
GMV-N560U/C-T+GMV-N560U/C-T+GMV-N280U/C-T	196	840+840+280
GMV-N560U/C-T+GMV-N560U/C-T+GMV-N560U/C-T	224	840+840+560
	252	840+840+840

(2) Connection method 2: one-to-more

The AHU-KIT as below can adopt one-to-more connection method with VRF outdoor unit. Total capacity of AHU-KIT should be 50%~110% of that of outdoor unit.

Model	Capacity in application (kW)	Capacity DIP
GMV-N36U/C-T	2.8	28
	3.6	36
GMV-N71U/C-T	4.5	45
	5.6	56
	7.1	71
GMV-N140U/C-T	9	90
	11.2	112
	14	140
GMV-N280U/C-T	22.4	224
	28	280

(3) Connection method 3: one-to-more (mixed connection)

The AHU-KIT as below can adopt one-to-more connection method with general VRF indoor unit. Total capacity of AHU-KIT and VRF indoor unit should be 50%~110% of that of outdoor unit. Total capacity of AHU-KIT cannot exceed 30% of that of outdoor unit.

Model	Capacity in application (kW)	Capacity DIP
GMV-N36U/C-T	2.8	28
	3.6	36
GMV-N71U/C-T	4.5	45
	5.6	56
	7.1	71
GMV-N140U/C-T	9	90
	11.2	112
	14	140
GMV-N280U/C-T	22.4	224
	28	280



Notes:

- ① When connecting AHU-KIT with general VRF indoor unit, capacity requirement shall be followed strictly. Otherwise, it may affect the operation, or even damage the unit.
- ② One-to-more means matching between indoor unit and outdoor unit.

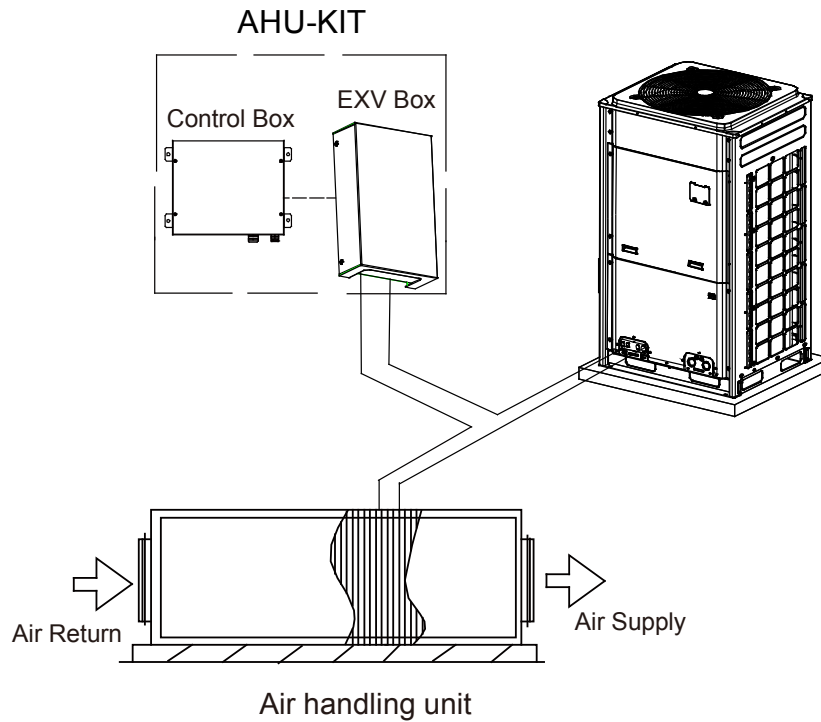

Figure 2-4 AHU-KIT one-to-one (single unit) connection diagram

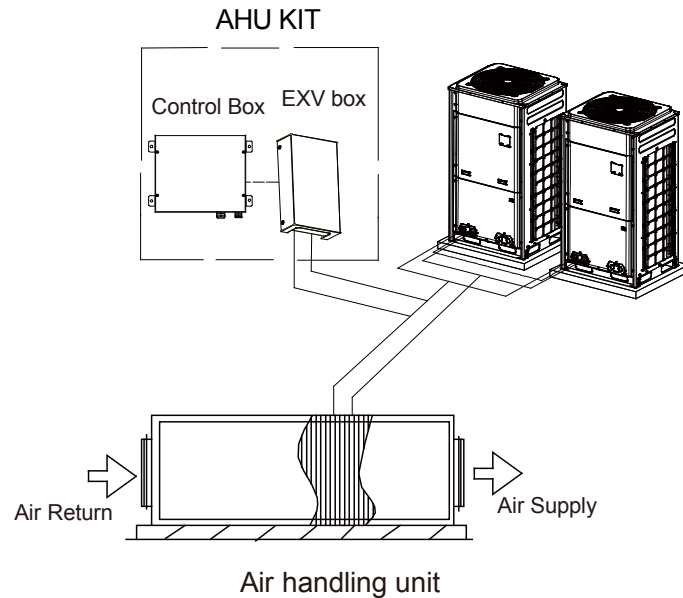

Figure 2-5 AHU-KIT one-to-one (combination outdoor unit) connection diagram

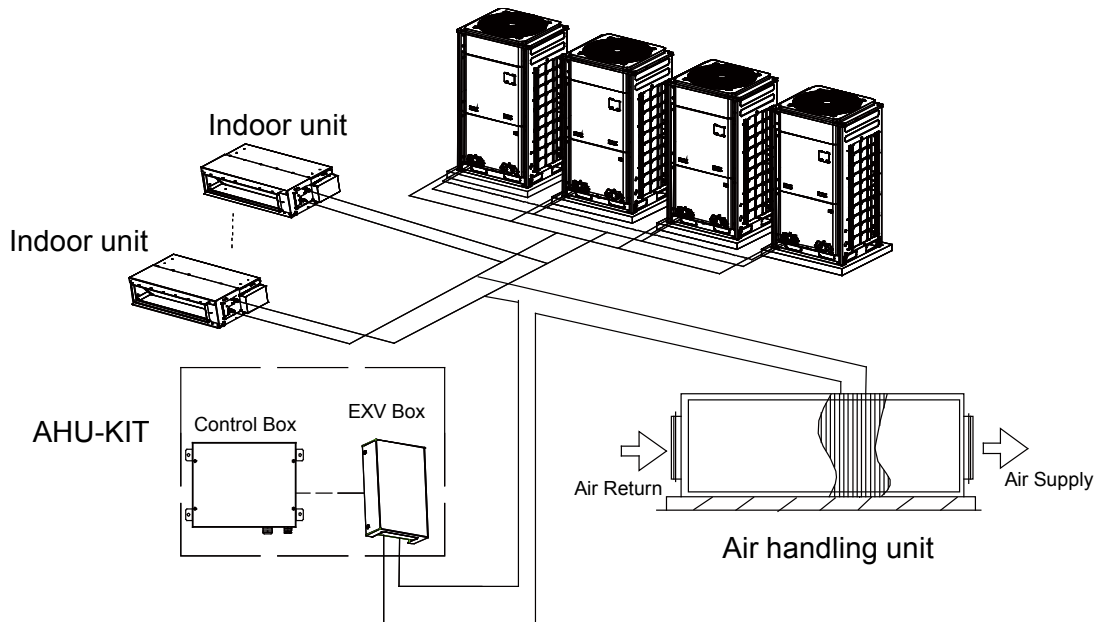

Figure 2-6 AHU-KIT one-to-more (hybrid connection) connection diagram

3 Preparations for Installation

3.1 Before Installation



Note:

Product graphics are only for reference. Please refer to actual products. Unspecified measure unit is mm.

- (1) This equipment is designed for R410A system, and the designed working pressure is 4.3 MPa or 43 bar.
- (2) Working Ambient Temp.: $T_{max}=45^{\circ}\text{C}$.
- (3) Precautions for R410A:
 - 1) The refrigerant requires strict cautions for keeping the system clean, dry and tight.

—Clean and dry: Foreign materials (including mineral oils or moisture) should be prevented from getting mixed into the system.

—Tight: Read this manual carefully and follow these procedures correctly.

- 2) Since R410A is a mixed refrigerant, the required additional refrigerant must be charged in its liquid state. (If the refrigerant is in state of gas, its composition changes and the system will not work properly).
- (4) The connected air handling units must have heat exchangers designed exclusively for R410A .
- (5) Never use this appliance in a place with inflammable and explosive gas.
- (6) For the following items, take special care during construction and check after installation is finished:

Tick <input checked="" type="checkbox"/> when checked
<input type="checkbox"/> Are the temperature sensors fixed firmly?
Temperature sensor may come loose.
<input type="checkbox"/> Is the capacity code setted correctly?
System performance may not reach relevant requirements or will lead to reliability problem.
<input type="checkbox"/> Is the control box fixed firmly?
The unit may drop, vibrate or make noise.
<input type="checkbox"/> Do electrical connections comply with specifications?
The unit may malfunction or components may burn out.
<input type="checkbox"/> Are wiring and piping correct?
The unit may malfunction or components may burn out.
<input type="checkbox"/> Is the unit safely grounded?
Dangerous at electric leakage.

3.2 Location for Installation

Select an installation site where the following conditions are fulfilled and that meets your customer’s approval.

- (1) The EXV box and the control box should be installed inside.
- (2) Do not install the EXV box in or on the outdoor unit.
- (3) Do not put the option boxes in direct sunlight. Direct sunlight will increase the temperature inside the option boxes and may reduce its lifetime and influence its operation.
- (4) Choose a flat and strong mounting surface.
- (5) Make sure there is enough free space in front and in the side of the AHU-KIT unit for future maintenance.
- (6) The installation site should be far away from heat source, inflammable gas and smoke.
- (7) Keep the air handling unit, power supply wiring and transmission wiring at least 1 m away from televisions and radios. This is to prevent image interference and noise in those electrical appliances. (Noise may be generated depending on the conditions under which the electric wave is generated, even if 1 m is kept.)
- (8) Make sure the electronic expansion valve is installed in an upright position.



Notes:

- ① Do not install or operate the unit in rooms mentioned below:
 - a) Where mineral oil, like cutting oil is present.
 - b) Where the air contains high levels of salt such as air near the ocean.
 - c) Where sulphurous gas is present such as that in areas of hot spring.
 - d) In vehicles or vessels.
 - e) Where voltage fluctuates a lot such as that in factories.
 - f) Where high concentration of vapor or spray are present.
 - g) Where machines generating electromagnetic waves are present.
 - h) Where acidic or alkaline vapor is present.
- ② Installing this unit must comply with the relevant local and national codes.
- ③ Connecting the power after all installation works are done.

3.3 Requirements for Communication Wire



Note:

If the unit is installed in the place with strong electromagnetic interference, shielded wire must be applied on the communication wire between indoor unit (AHU-KIT) and wired controller. Twisted pair wire with shielding function must be applied on the communication wire between indoor unit and indoor unit (outdoor unit).

3.3.1 Selecting Communication Wire for AHU-KIT and Wired Controller

Wire Type	Total Length of Communication wire L(m)	Wire Gauge (mm ²)	Remark
Light/Common PVC Jacket Soft Wire	$L \leq 250$	2×0.75 ~ 2×1.25	The total length of communication wire should not exceed 250m.
Light shield/Common PVC Jacket Soft Wire	$L \leq 250$	2×0.75 ~ 2×1.25	The shield cable is required when the unit is installed in the environment of strong magnetic or interference.

Connection between AHU-KIT and wired controller is shown as follows:

- (1) When one AHU-KIT is connected to one AHU, you can adopt the connection ways of one wired controller to one AHU-KIT or one wired controller to several AHU-KITs (group control, $n \leq 16$).
- (2) When several AHU-KITs are in parallel connection with one AHU, you can only adopt the way of one wired controller to several AHU-KITs (group control, $n \leq 3$).

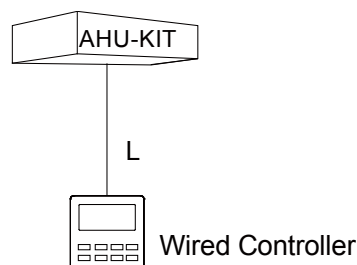

Figure 3-1 One wired controller to one AHU-KIT

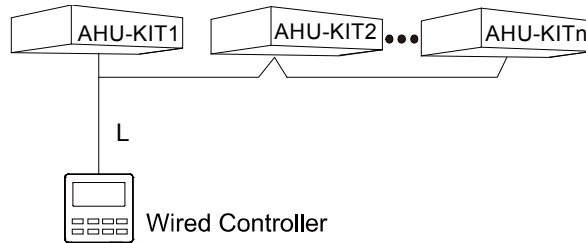

Figure 3-2 One wired controller to several AHU-KITs

3.3.2 Select Communication Wire for AHU-KIT and Outdoor Unit

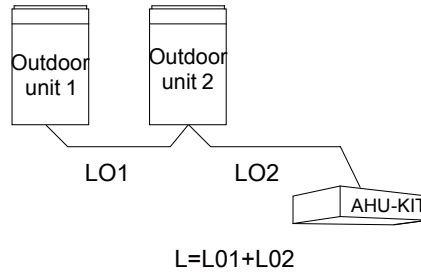

Figure 3-3

Wire Type	Total Length of Communication wire L(m)	Wire Gauge (mm ²)	Remark
Light/Common PVC Jacket Soft Wire	$L \leq 1000$	$\geq 2 \times 0.75$	If wire gauge is $2 \times 1 \text{ mm}^2$, then it's OK to increase the length of communication wire. But total length should not exceed 1500m.
Lightshield/Common PVC Jacket Soft Wire	$L \leq 1000$	$\geq 2 \times 0.75$	The shield cable is required when the unit is installed in the environment of strong magnetic or interference.

3.4 Wiring Requirements

Power Cord Size and Air Switch Capacity:

Model	Power Cord Size	Air Switch Capacity (A)	Ground Wire	Power Cord
			Minimum Sectional Area (mm ²)	Minimum Sectional Area (mm ²)
GMV-N36U/C-T	220~240V/1ph/50Hz & 208~230V/1ph/60Hz	6	1	1
GMV-N71U/C-T		6	1	1
GMV-N140U/C-T		6	1	1
GMV-N280U/C-T		6	1	1
GMV-N560U/C-T		6	1	1



Notes:

- ① Use copper wire only as unit's power cord. Operating temperature should be within its rated value.
- ② Above selection requirements: Power cord size is based on BV single-core wire (2~4pc) at 40°C ambient temperature when laying across plastic pipe. Air switch is D type and used at 40°C. If actual installation condition varies, please lower the capacity appropriately according to the specifications of power cord and air switch provided by manufacturer.
- ③ Install cut-off device near the unit. The minimum distance between each stage of cut-off device should be 3 mm (The same for both indoor unit and outdoor unit).

3.5 Piping Requirements

3.5.1 Selection of Piping Requirements

- (1) Ensure the inside of the pipes is clean and no foreign materials.
- (2) Pipe specifications:

R410A System		
Pipe Φ (mm)	Thickness(mm)	Temper grade of piping material
$\Phi 6.35$	≥ 0.8	0
$\Phi 9.52$	≥ 0.8	0
$\Phi 12.70$	≥ 0.8	0
$\Phi 15.9$	≥ 1.0	0
$\Phi 19.05$	≥ 1.0	1/2H
$\Phi 22.2$	≥ 1.2	1/2H
$\Phi 25.40$	≥ 1.2	1/2H
$\Phi 28.6$	≥ 1.2	1/2H
$\Phi 31.8$	≥ 1.3	1/2H
$\Phi 34.90$	≥ 1.3	1/2H
$\Phi 38.10$	≥ 1.5	1/2H
$\Phi 41.30$	≥ 1.5	1/2H
$\Phi 44.5$	≥ 1.5	1/2H
$\Phi 51.4$	≥ 1.5	1/2H
$\Phi 54.1$	≥ 1.5	1/2H

3.5.2 Piping Design

When one AHU-KIT is connected to one AHU, the piping diagram is as follows:

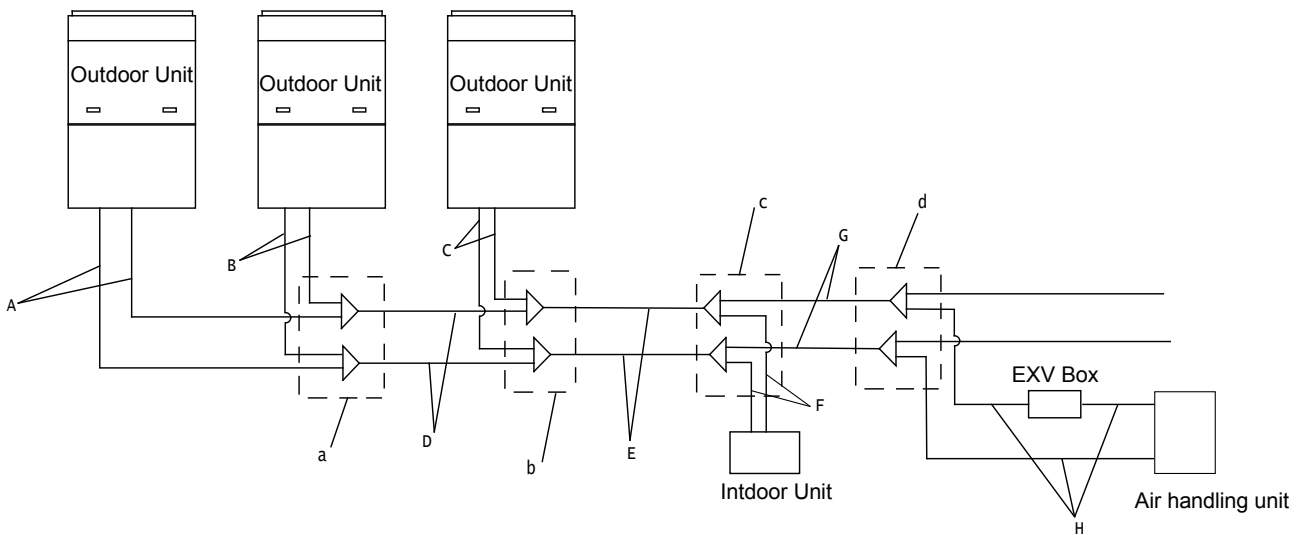

Figure 3-4 One AHU-KIT to one AHU

When several AHU-KITs are connected to one AHU, the piping diagram is as follows:

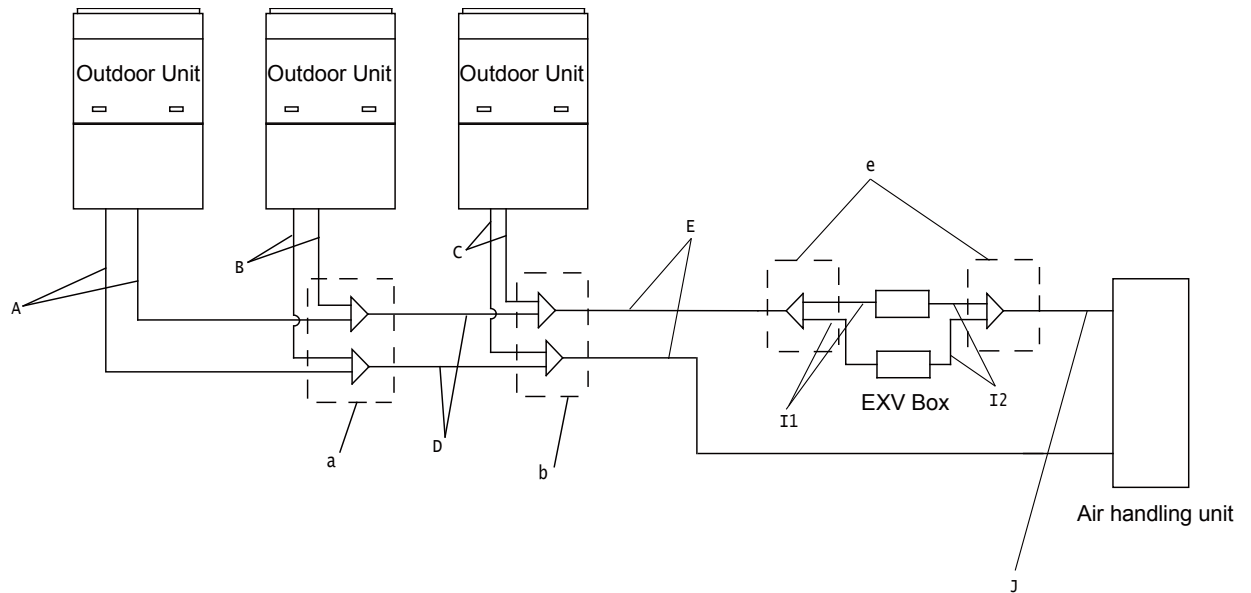

Figure 3-5 Several AHU-KITs to one AHU

3.5.2.1 Selection of Branch Pipe

(1) Branch pipes (a, b) between outdoor units shall be selected according to the total capacity of outdoor unit, as follows:

Selection of branch pipe between ODU modules	Model
	ML01/A

(2) Branch pipe (c, d) between indoor units shall be selected according to the total capacity of downstream IDUs as follows:

Selection of branch pipe between indoor units	Total rated capacity of downstream IDUs X(kW)	Model
Y-type Manifold	$X < 20.0$	FQ01A/A
	$20.0 \leq X \leq 30.0$	FQ01B/A
	$30.0 < X \leq 70.0$	FQ02/A
	$70.0 < X \leq 135.0$	FQ03/A
	$135.0 < X$	FQ04/A
T- type Manifold	$X \leq 40.0$	FQ14/H1
	$X \leq 68.0$	FQ18/H1
	$68.0 < X$	FQ18/H2

(3) When several AHU-KITs are connected to one AHU, branch pipe (e) shall be selected according to the following table:

Model	Branch pipe	Quantity
GMV-N560U/C-T+GMV-N140U/C-T	FQ01U/A	1
GMV-N560U/C-T+GMV-N280U/C-T	FQ01U/A	1
GMV-N560U/C-T+GMV-N560U/C-T	FQ01U/A	1
GMV-N560U/C-T+GMV-N560U/C-T+GMV-N140U/C-T	FQ01U/A	2
GMV-N560U/C-T+GMV-N560U/C-T+GMV-N280U/C-T	FQ01U/A+FQ02U/A	1+1
GMV-N560U/C-T+GMV-N560U/C-T+GMV-N560U/C-T	FQ01U/A+FQ02U/A	1+1

3.5.2.2 Selection of Piping Dimension

Piping dimension can be selected according to the total rated capacity of upstream or downstream modules. Detailed requirements are as below:

- (1) Piping (A, B, C) from ODU to branch pipe shall be selected according to the rated capacity of ODU.
- (2) Piping D between branch pipes of ODU modules shall be selected according to the total rated capacity of upstream modules.
- (3) Piping E and G of branch pipe at IDU side shall be selected according to the total rated capacity of downstream IDUs.
- (4) Piping F from IDU branch pipe to IDU shall be selected according to the rated capacity of IDU.
- (5) Piping (I1, I2, J, H) between branch pipe and AHU-KIT shall be selected according to the capacity of AHU-KIT; Relationship between capacity and piping dimension is as below:

Rated capacity (kW)	Gas pipe (mm)	Liquid pipe (mm)
$Q \leq 2.8$	$\Phi 9.52$	$\Phi 6.35$
$2.8 < Q \leq 5$	$\Phi 12.7$	$\Phi 6.35$
$5 < Q \leq 14.2$	$\Phi 15.9$	$\Phi 9.52$
$14.2 < Q \leq 25.2$	$\Phi 19.05$	$\Phi 9.52$
$25.2 < Q \leq 28$	$\Phi 22.2$	$\Phi 9.52$
$28 < Q \leq 40$	$\Phi 25.4$	$\Phi 12.7$
$40 < Q \leq 45$	$\Phi 28.6$	$\Phi 12.7$
$45 < Q \leq 68$	$\Phi 28.6$	$\Phi 15.9$
$68 < Q \leq 96$	$\Phi 31.8$	$\Phi 19.05$
$96 < Q \leq 135$	$\Phi 38.1$	$\Phi 19.05$
$135 < Q \leq 186$	$\Phi 41.3$	$\Phi 19.05$
$186 < Q$	$\Phi 44.5$	$\Phi 22.2$



Notes:

- ① As the capacity of AHU-KIT is adjustable, please select piping according to actual capacity in the project.
- ② If the ex-factory pipe diameter of AHU adapter is inconsistent with the actual required pipe diameter for the project, please conduct conversion on site.

3.6 Capacity Setting

Capacity ranges of different AHU-KIT unit are as follows:

Model	Acquiescent capacity (kW)	Adjustable capacity (kW)
GMV-N36U/C-T	3.6	2.8/3.6
GMV-N71U/C-T	7.1	4.5/5.6/7.1
GMV-N140U/C-T	14	9.0/11.2/14.0
GMV-N280U/C-T	28	22.4/28.0/33.5/40.0/45.0
GMV-N560U/C-T	56	50.4/56.0/84.0

Different capacities of same model of AHU-KIT unit are achieved through dialing capacity code of mainboard (shown as "S1"). Capacity code setting is shown as follows:

S1					Capacity (kW)
1	2	3	4	5	
0	1	0	0	0	2.8
0	0	1	0	0	3.6
0	1	1	0	0	4.5
0	0	0	1	0	5.6
0	1	0	1	0	7.1
0	0	1	1	0	9
0	1	1	1	0	11.2
0	0	0	0	1	14
1	1	0	0	1	22.4
1	0	1	0	1	28
0	1	1	0	1	33.5
0	0	0	1	1	40
1	0	0	1	1	45
0	1	0	1	1	50.4
1	1	0	1	1	56
0	0	1	1	1	84

Please ensure dialing the code switch properly in place instead of middle position. Setting the switch to "ON" stands for "0", otherwise stands for "1".

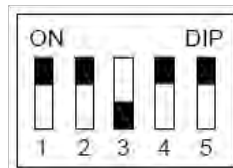

(Notes: The black part is the deflector rod.) The figure shows that the addresses of "1,2,3,4,5" are "0,0,1,0,0".



Notes:

- ① The selected air handling unit must be designed for R410A.
- ② Extraneous substances (including mineral oils or moisture) must be prevented from getting mixed into the system.

4 Product Installation

4.1 Unit Dimensions and Maintenance Space

(1) Size of control box for GMV-N36U/C-T、GMV-N71U/C-T、GMV-N140U/C-T、GMV-N280U/C-T and GMV-N560U/C-T (Unit: mm):

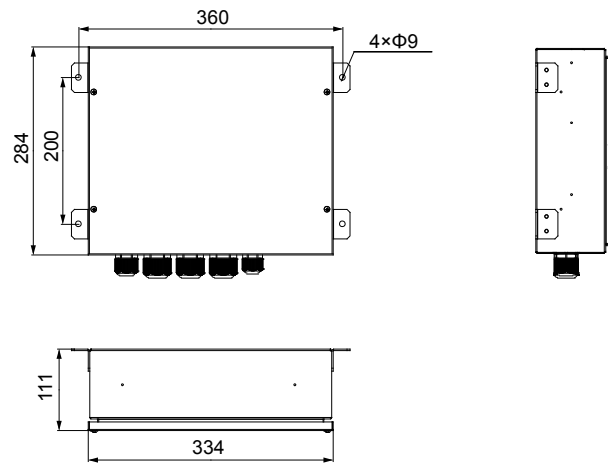

Figure 4-1

(2) Size of EXV box for GMV-N36U/C-T (Unit: mm):

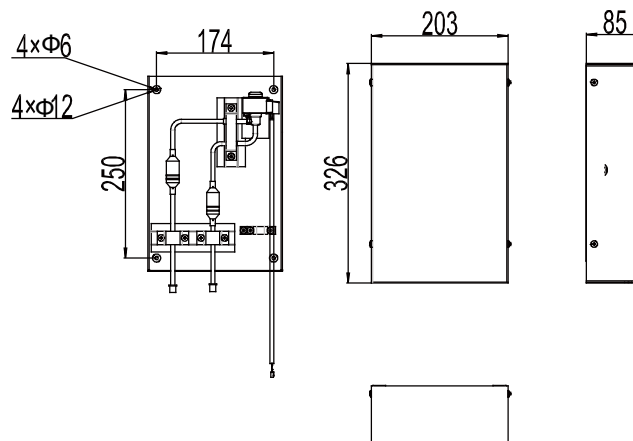

Figure 4-2

(3) Size of EXV box for GMV-N71U/C-T、GMV-N140U/C-T and GMV-N280U/C-T (Unit: mm):

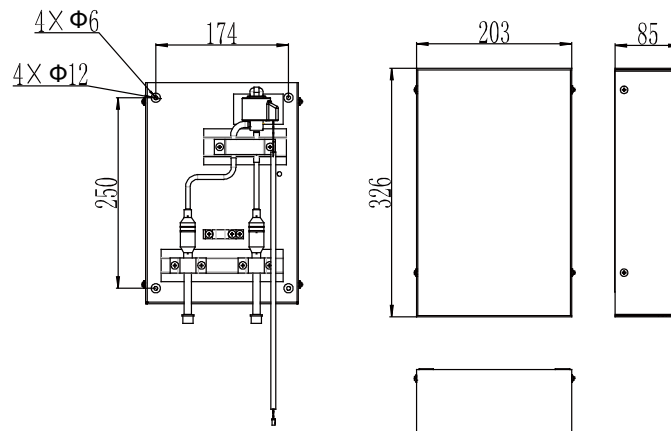

Figure 4-3

(4) Size of EXV box for GMV-N560U/C-T (Unit: mm):

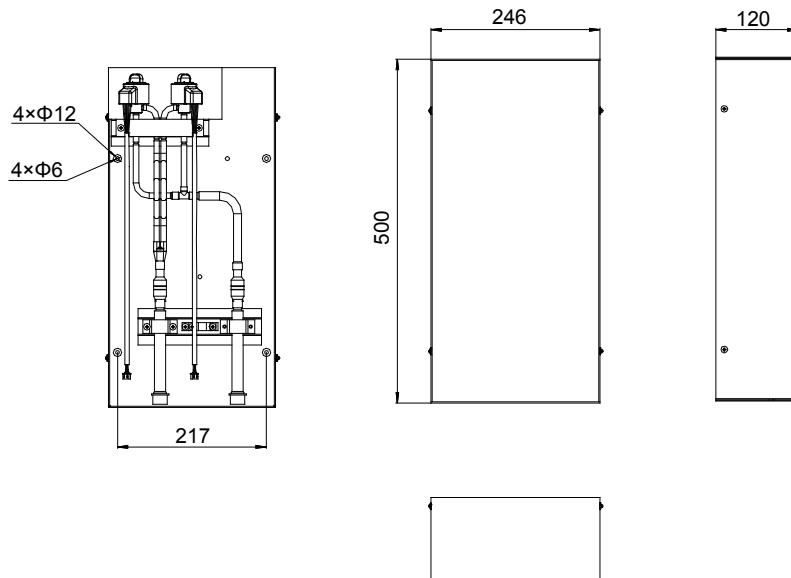
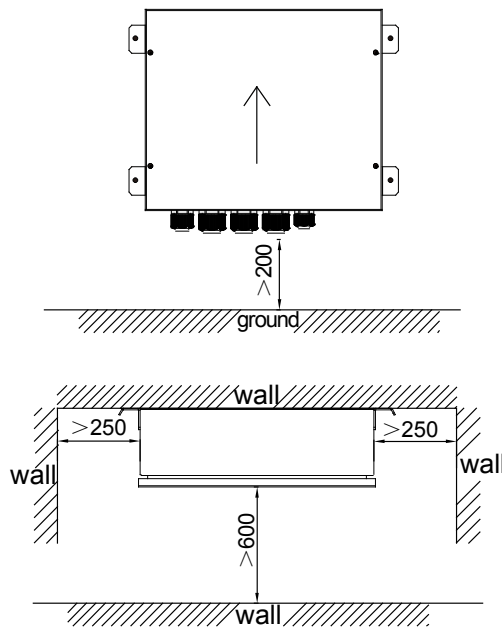

Figure 4-4

(5) Maintenance space of control space (Unit: mm):



The control box must be installed upwards as the direction of the arrow shown in the figure

Figure 4-5

(6) Maintenance space of EXV box (Unit: mm):

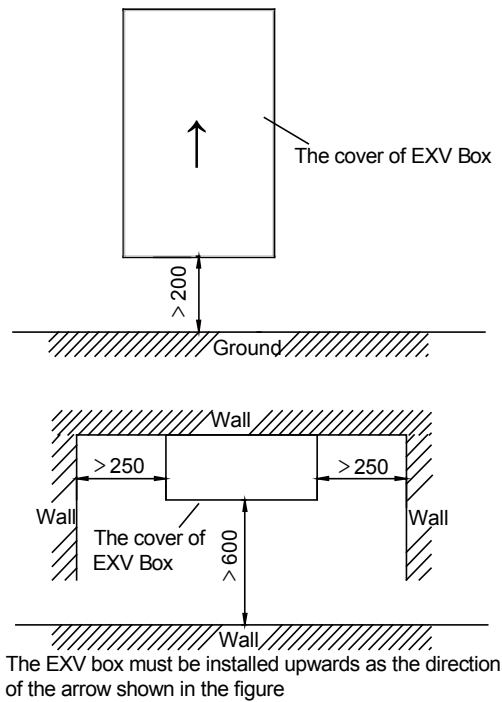

Figure 4-6

4.2 EXV Installation

4.2.1 Mechanical Installation

- (1) Remove the EXV box cover by unscrewing screws.
- (2) Drill 4 holes on correct position (measurements as indicated in figure below) and fix the valve kit box securely with 4 screws through the provided holes $\text{Ø}12$ mm.



Notes:

- ① Make sure that the EXV box is installed upwards.
- ② Make sure there is enough free space in front and in the side of the box for future maintenance.

4.2.2 Brazing Work

- (1) Prepare the inlet/outlet field piping just in front of the connection (do not braze yet).

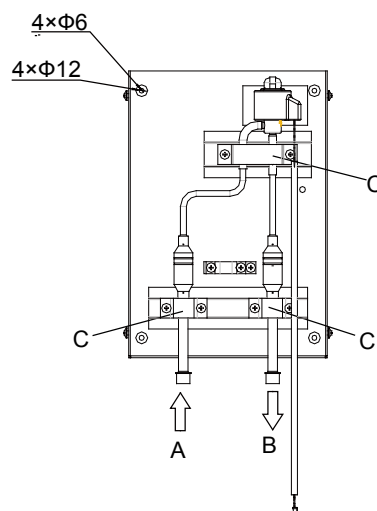

Figure 4-7

A: Inlet coming from the outdoor unit

B: Outlet to air handling unit

C: Wire clamp

- (2) Remove the wire clamp (C) by unscrewing 6xM4.2.
- (3) Braze the field piping.



Notes:

- ① Make sure there is nitrogen protection during welding.
Braze without carrying out nitrogen replacement or releasing nitrogen into the piping will create large quantities of oxidized film on the inside of the pipes, adversely affecting valves and compressors in the refrigerating system and preventing normal operation.
- ② When brazing while inserting nitrogen into the piping, nitrogen must be set to 0.02 MPa with a pressure-reducing valve (=just enough so that it can be felt on the skin).

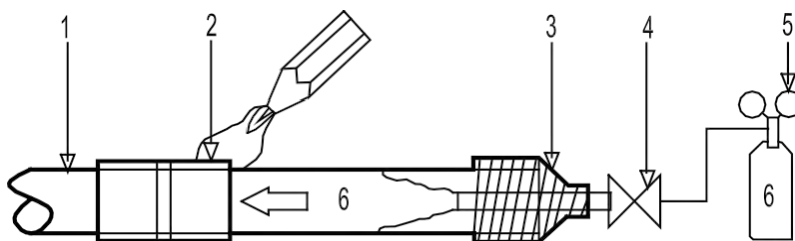

Figure 4-8

- 1: Refrigerant piping
- 2: Part to be brazed
- 3: Taping
- 4: Hand valve
- 5: Pressure-reducing valve
- 6: Nitrogen

For details, see manual of the outdoor unit.

- ③ Make sure to cool the filters and valve body with a wet cloth and make sure the body temperature does not exceed 120°C during brazing.
- ④ Make sure that the other parts such as electrical box, tie wraps and wires are protected from direct brazing flames during brazing.
- ⑤ The EXV box is required to be installed in a vertical direction within the range of 90±15° (not allowed for horizontal work). Welding the connection tubes first before refrigerant pipes in order to avoid face-down soldering.
- ⑥ All field piping must be provided by a licensed refrigeration technician and must comply with the relevant local and national codes.
 - a) For refrigerant piping of outdoor unit, refer to the installation manual supplied with the outdoor unit.
 - b) The maximum allowed piping length depends on the connected outdoor model.
- ⑦ Secure the wire clamp (C) in place again (6xM4.2).
- ⑧ Make sure that field pipes are fully insulated. Make sure that there is no gap between both ends in order to avoid condensation dripping (finish the connection with tape eventually).

4.3 Piping Installation

When one AHU-KIT is connected to one AHU, the piping installation diagram is as follows:

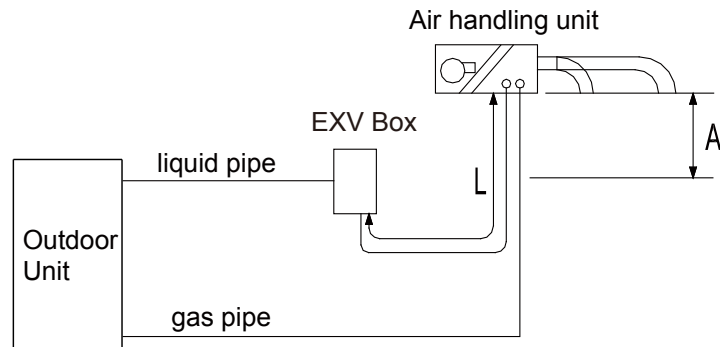

Figure 4-9

When several AHU-KITs are connected to one AHU, the piping installation diagram is as follows:

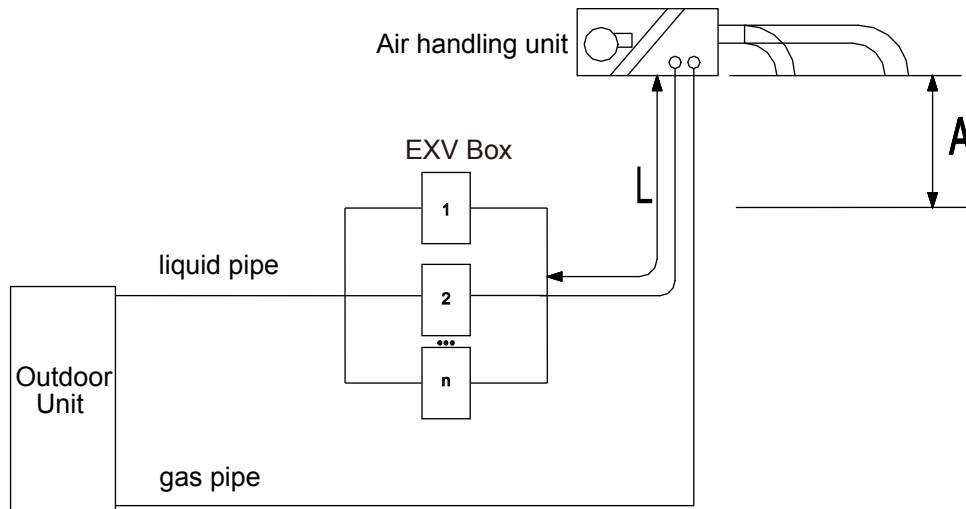

Figure 4-10



Notes:

A: When the air handling unit is installed at the top of the EXV box, vertical distance between the bottom of the air handling unit to the EXV box is no more than 2 m; if the air handling unit is installed under the EXV box, vertical distance between the bottom of the air handling unit to the EXV box is no more than 2 m.

L: The length of liquid pipe between the air handling unit to EXV box is no more than 2 m.

L is to be considered as a part of the total maximum piping length. See installation manual of the outdoor unit for piping installation.

4.4 Installation of the Control Box

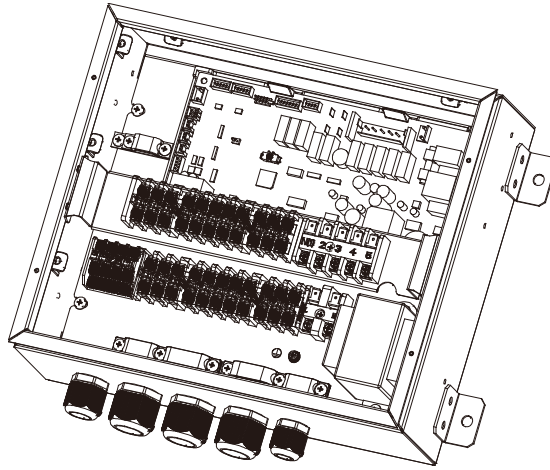

Figure 4-11

4.4.1 Mechanical Installation

- (1) Fix the control box with its hanger brackets to the mounting surface.
- (2) Open the lid of the control box.
- (3) For electrical wiring: refer to the following contents.
- (4) Install the screw nuts.
- (5) Close the unnecessary openings.
- (6) Close the lid securely after installation to ensure that the control box is watertight.

4.4.2 Wire connection Inside the Control Box

4.4.2.1 Wiring of Control Accessories when One AHU-KIT is Connected to One AHU



Notes:

- ① Pull the wires inside through the screw nut and close the nut firmly in order to ensure a good pull relieve and water protection.
- ② The cables require an additional pull relief. Fixing the cable with the wire clamp.

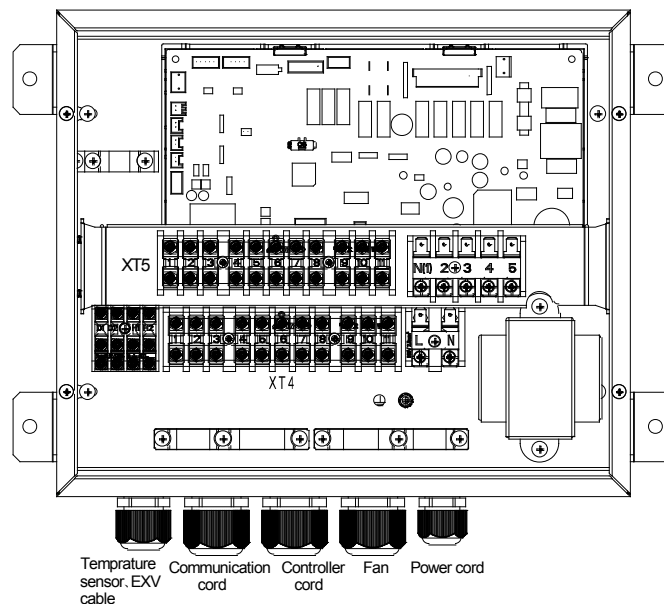

Figure 4-12

Precautions:

- ① Temperature sensor cable and remote controller wire should be kept away from power cable in a distance of at least 50mm. Violating this rule may generate electric noise and lead to malfunctions.
- ② Use wires as specified and connect them tightly with wiring terminals. Keep the wires in order and do not obstruct other devices. Insecure connection may result in overheating or even cause electric shock or fire hazard.

Wiring connection:

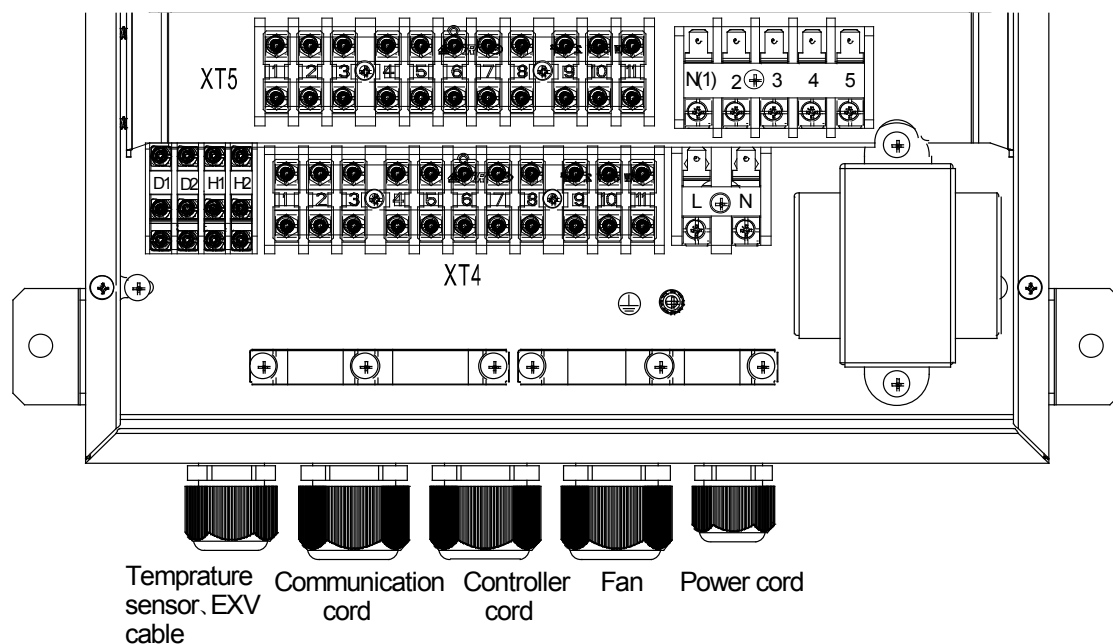

Figure 4-13

Connecting cables according to the following instructions, as figure shown above.

- L..... Live
 N..... Neutral
 PE..... Protective earth (screw)
 2.....High gear of fan
 3.....Middle gear of fan
 4..... Low gear of fan
 D1/D2.....Communication wires
 H1/H2.....Wired controller



Notes:

- ① The 2, 3, 4 of fan gear lines are shorted by the factory default.
- ② Neutral line of fan connects to the N (1).
- ③ It can be connected to any of them (2, 3, 4) when there is only one gear.
- ④ Disconnect the short cable between 2 and 3 when there are two gears, then connect the high gear cable to 2, and connect low gear cable to either 3 or 4.
- ⑤ When there are three gears, disconnect the short cables between 2 and 3, 3 and 4, then connect the high gear cable, middle gear cable and low gear cable to 2,3,4 for each.
- ⑥ Pull the wires inside through the screw nut and close the nut firmly in order to ensure a good

pull relieve and water protection.

- ⑦ Put through the wires to the coil, tighten the coil while maintaining loose condition of wires to ensure it is not closely tied up and is waterproof.
- ⑧ Wiring connection of XT4 and XT5 refer to the following contents.

4.4.2.2 Wiring of Control Accessories when Several AHU-KITs are in Parallel Connection with One AHU

For the wiring of control accessories when several AHU-KITs are in parallel connection with one AHU, connect fan control wire and external signal feedback signal wire of air handling unit to any one AHU-KIT. Please refer to the wiring method of AHU-KIT for the connection method.

4.5 Installation of the Temperature Sensors

4.5.1 Refrigerant Temperature Sensors

Location of the temperature sensor: A correct installation of the temperature sensors is required to ensure a good operation:

- (1) IN Temp. sensor(Liquid Temp. sensor)

Install the IN temperature sensor after the distributor and on the coldest temperature pipe of a heat exchanger.

- (2) OUT Temp. sensor (Gas Temp. sensor)

Install the OUT temperature sensor 200mm after the outlet of the heat exchanger.

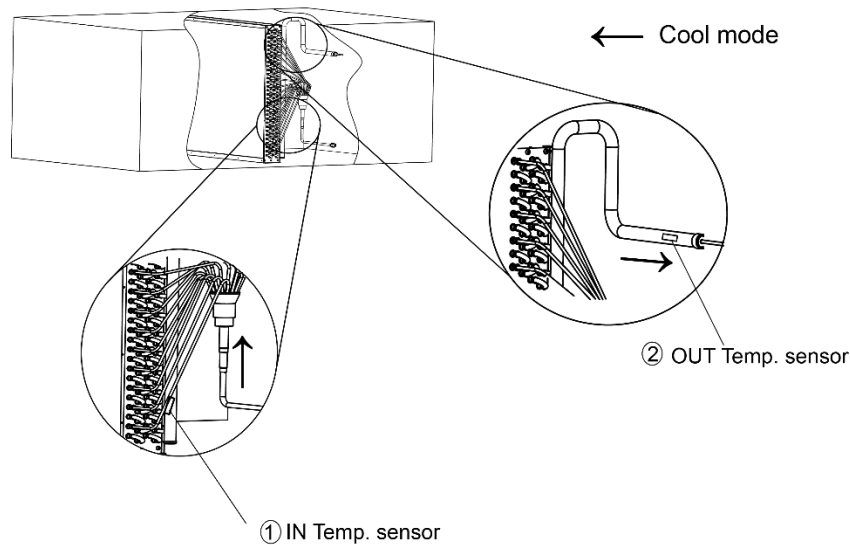

Figure 4-14

- ①IN Temp. sensor (Liquid Temp. sensor)
- ②OUT Temp. sensor (Gas Temp. sensor)

Installation of the temperature sensor cable :

- (1) The length of temperature sensor wire is 10 m.
- (2) Put the temperature sensor cable in an individual protective tube.
- (3) Apply stress release in the temperature sensor wire to prevent the temperature sensor wire from getting loose due to stress. Stress or looseness of temperature sensor wire will lead to poor contact and inaccuracy of temperature measuring.

Fixation of the temperature sensor:

- 1) Put the temperature sensor wire slightly down to avoid water accumulation on top of the temperature sensor.

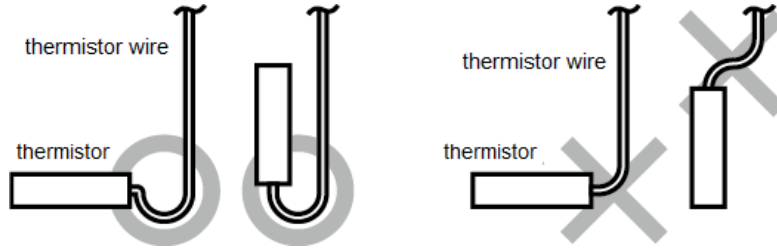

Figure 4-15

- 2) Keep the temperature sensor and air handling unit in good contact. Put the top of the temperature sensor on the air handling unit, because the top of temperature sensor is the most sensitive part. Please fix the temperature sensor on the horizontal plane of copper tube (within $\pm 30^\circ$), and make them close together.

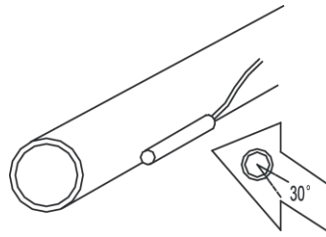

Figure 4-16

- 3) Fix the temperature sensor with insulating aluminum tape in order to ensure good heat transference.

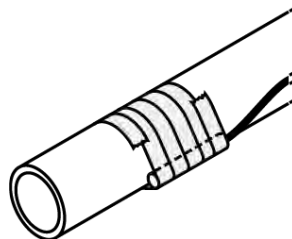

Figure 4-17

- 4) Cover the temperature sensor with rubber belt to prevent looseness of temperature sensor.

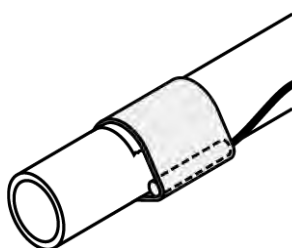

Figure 4-18

- 5) Use two wire ties to bind the temperature sensor securely.

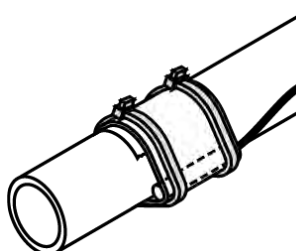

Figure 4-19

- 6) Wrap the temperature sensor with insulator.

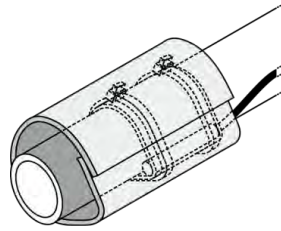

Figure 4-20

4.5.2 Air Temperature Sensor and Air Outlet Temperature Sensor

The air temperature sensor can be installed in the space which needs temperature control, or the inlet scoop of air handling unit.

The air temperature outlet sensor can be installed in the outlet scoop of air handling unit.



Notes:

- ① For connection to outdoor unit and to AHU-KIT unit: Pull the wires inside through the screw nut and close the nut firmly in order to ensure a good pull relieve and water protection.
- ② The cables require an additional pull relief. Fixing the cable with the wire clamp.
- ③ The connection of temperature sensor requires enough space.

4.5.3 Installation of Temperature Sensor When Several AHU-KITs are in Parallel Connection with One AHU

When several AHU-KITs are in parallel connection with one AHU, all linkage AHU-KIT inlet pipes' and outlet pipes' temperature sensor must be installed at the position of corresponding pipeline of air handling unit. Install the ambient temperature sensor at the same position of air return outlet. Please refer to above installation method of single AHU-KIT temperature sensor. The installation diagram is as below:

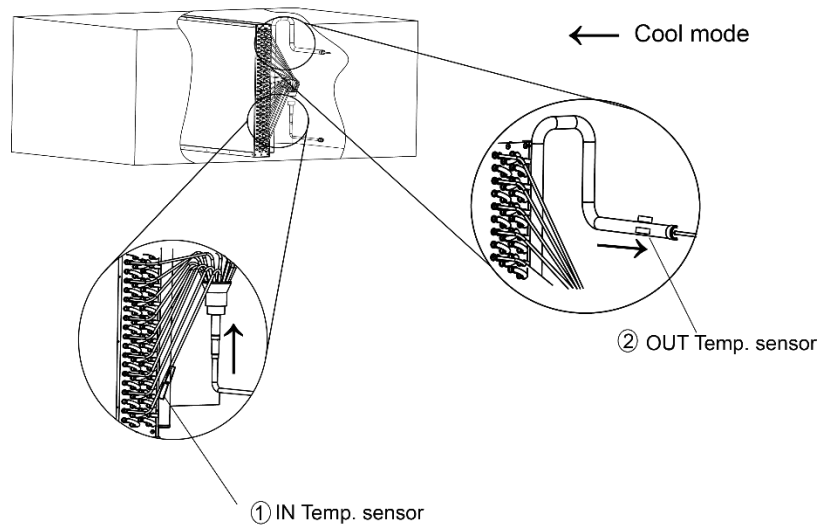

Figure 4-21

① IN Temp. sensor (Liquid Temp. sensor)

② OUT Temp. sensor (Gas Temp. sensor)

4.6 Installation of the EXV Cable

Installation steps:

- (1) Making the cable terminal through the Cable-Cross Loop , and then winding the cable on the magnetic ring for three times, at last inserting the terminal into a corresponding slot(see circuit diagram).
- (2) Using bundles to fix the magnetic ring is required. It's also need to insert the bundle into the reserved hole on the control box.
- (3) Fixing the cable with the wire clamp, and tightening the Cable-Cross Loop.

Installation requirements:

- (1) Ensure that the cable in the control box is in a relaxed state, and both the joint of terminal and the fixed place of magnetic ring are all not under a stress.
- (2) Ensure that the cable sheath port is located in the control box in order to prevent the rain.

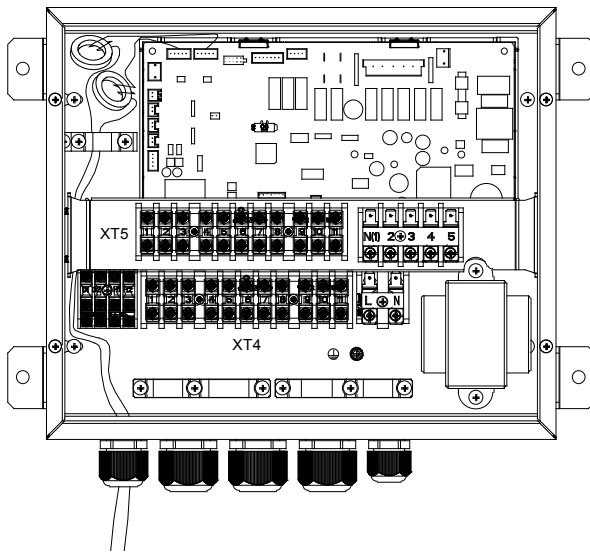

Figure 4-22

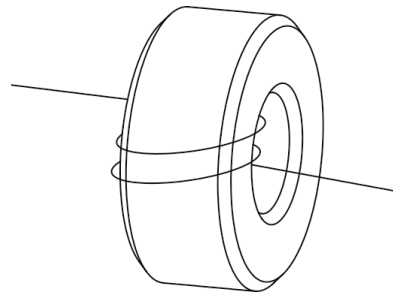

Figure 4-23

The quantity of expansion valve coil is determined by the actual number of fittings , The length of EXV Cable wire is 10 m (71,140,280,560 type) or 2.5 m (36 type).

4.7 Installation of Wired Controller

Please refer to User Manual of Wired Controller for the installation details.



Note:

When installation is finished, the unit must be tested and debugged before operation. Please refer to Instruction Manual of ODU for auto addressing and debugging details.

5 Wire Connection



Notes:

- ① Units must be earthed securely, or it may cause electric shock.
- ② Please carefully read the wiring diagram before carry out the wiring work, incorrect wiring could cause malfunction or even damage the unit.
- ③ The capacity of power supply should be big enough.
- ④ The unit should be powered by independent circuit and specific socket.

- ⑤ The wiring should be in accordance with related regulations in order to ensure the units reliable running.
- ⑥ Install circuit breaker for branch circuit according to related regulations and electrical standards.
- ⑦ All wiring must use pressure terminal or single wire. Multi-twisted wire that connects directly to the wiring board may cause fire hazard.
- ⑧ Keep cable away from refrigerant piping, compressor and fan motor.
- ⑨ Do not alter the inner wires of air conditioner. Manufacturer does not assume responsibility for damage or abnormal operation due to this reason.
- ⑩ If the unit is installed in places with strong electromagnetic interference, it's recommended to use twin-twisted shield wire. During wire connection, please pay attention that the metal shield layer of the twin-twisted wire must be grounded(outer case) in order to prevent the unit from electromagnetic interference.
- ⑪ The communication wires should be separated from power cord and connection wire between indoor unit and outdoor unit.
- ⑫ The appliance shall be installed in accordance with national wiring regulations.
- ⑬ For security, it is suggested that the exposed wires of EXV and temperature sensors wrapped in insulated tubes for good isolation.

5.1 Connect Cables and Terminals of Wiring Board

- (1) Connection of Wire and Patch Board Terminal (as shown below)
 - 1) Strip about 25mm insulation of the wire end by stripping and cutting tool.
 - 2) Remove the wiring screws on the terminal board.
 - 3) Shape the tail of wire into ring by needle nose plier, and keep the gauge of ring in accordance with screw.
 - 4) Use the screwdriver for tightening the terminal.
- (2) The connection of stranded wire (as shown below)
 - 1) Strip about 10mm insulation of the end of stranded wire by stripping and cutting tool.
 - 2) Loosen the wiring screws on terminal board.
 - 3) Insert the wire into the ring tongue terminal and tighten by crimping tool.
 - 4) Use the screwdriver for tightening the terminal.

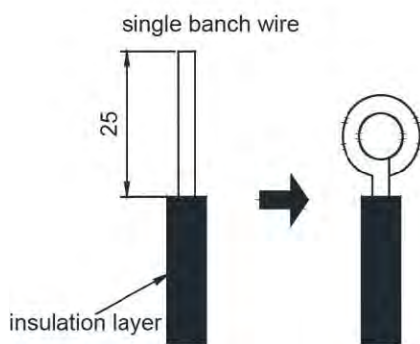

Figure 5-1

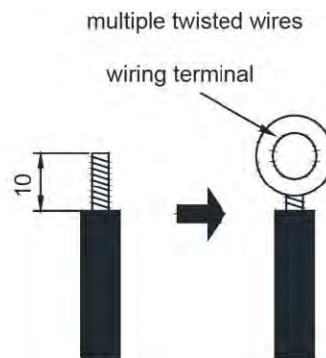

Figure 5-2

5.2 Power Cord Connection



Notes:

Each indoor unit must be installed with a independent circuit breaker for short-circuit protection and overload protection. In general, this circuit breaker is under close status.

During operation process, all indoor units and outdoor units in one system must be energized. Otherwise, the system can't operation normally.

Power supply of each indoor unit must be from the same source.

Power connection diagram for one AHU-KIT connected to one AHU:

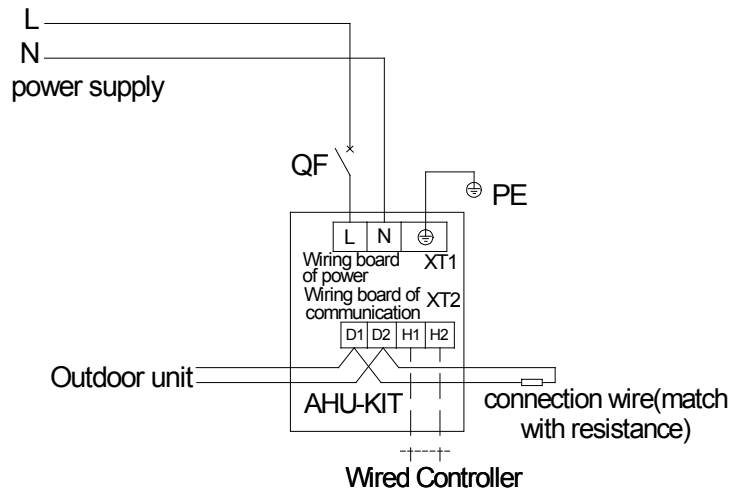

Figure 5-3

For units with single-phase power supply:

- (1) Detach the electric box lid.
- (2) Let the power cord pass through the wiring through-holes.
- (3) Connect the power cord to terminal “L, N, PE”.
- (4) Fix the power card with wiring clamp.

Power connection diagram for several AHU-KITs in parallel connection with one AHU:

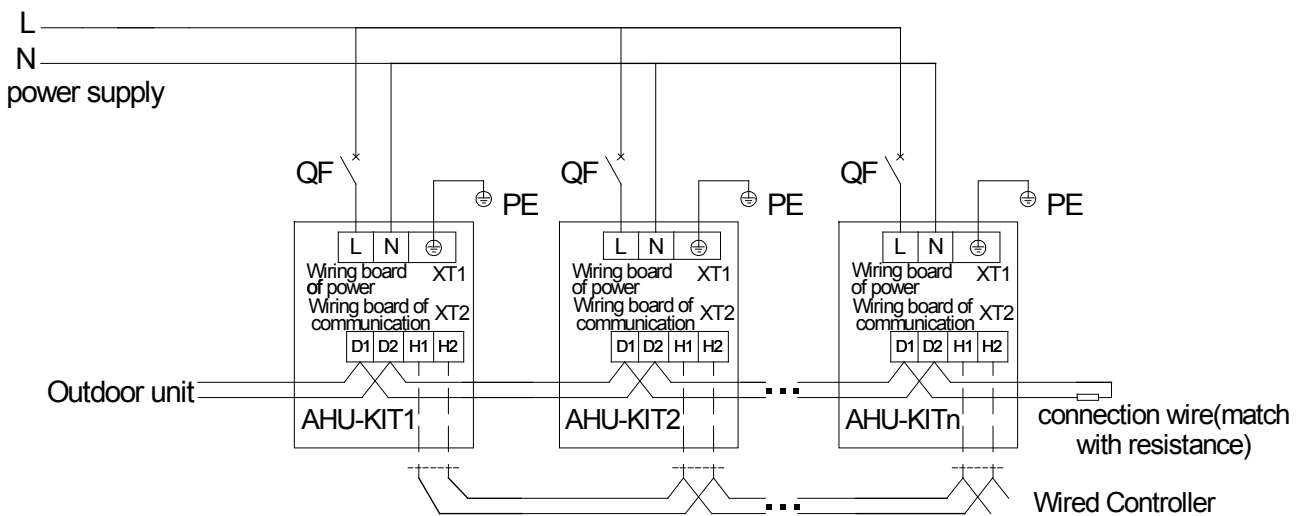

Figure 5-4

- (1) Detach the electric box lid.
- (2) Let the power cord pass through the wiring through-holes.

- (3) Connect the power cord to terminal “L, N, PE”.
- (4) Fix the power card with wiring clamp.

5.3 Connection of Communication Wire between Indoor Unit and Outdoor Unit (or Indoor Unit)

- (1) Detach the control box lid.
- (2) Let the Communication cable pass through the wiring through-holes.
- (3) Connect the communication wire to terminal D1 and D2 of indoor 4-bit wiring board, as shown below.

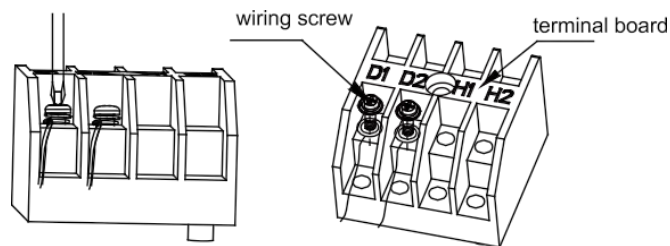

Figure 5-5

- (4) Fix the communication cable with clamp of electric box.
- (5) For more reliable communication, make sure connect the terminal resistor to the most downstream IDU of the communication bus (terminal D1 and D2), as shown below, terminal resistor is provided with each ODU.

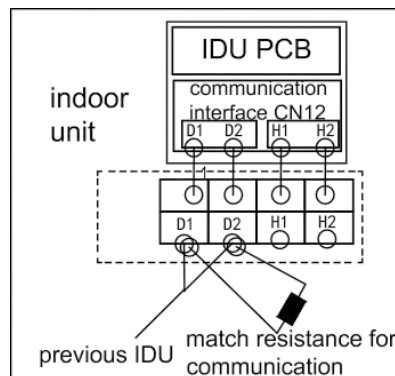

Figure 5-6

5.4 Connect Communication Wire of Wired Controller

- (1) Open electric box cover of indoor unit.
- (2) Let the communication wire go through the rubber ring.
- (3) Connect the communication wire to terminal H1 and H2 of indoor 4-bit wiring board.
- (4) Fix the communication wire with wire clip on the electric box.
- (5) Wiring instructions of remote receiving light board and wired controller.

As following shows the installation of wired controller:

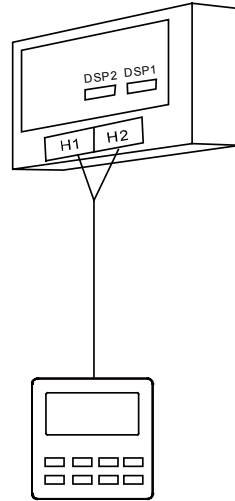

Figure 5-7

5.5 Illustrate for Connection of Wired Controller and Indoor Units (AHU-KIT) Network

- (1) Communication wire of indoor unit and outdoor unit (or indoor unit) is connected to D1, D2.
- (2) Wired controller is connected to H1, H2.
- (3) One indoor unit can connect two wired controllers that must be set as master one and slave one.

(4) One wired controller can control 16 indoor units in maximum at the same time (as shown below).

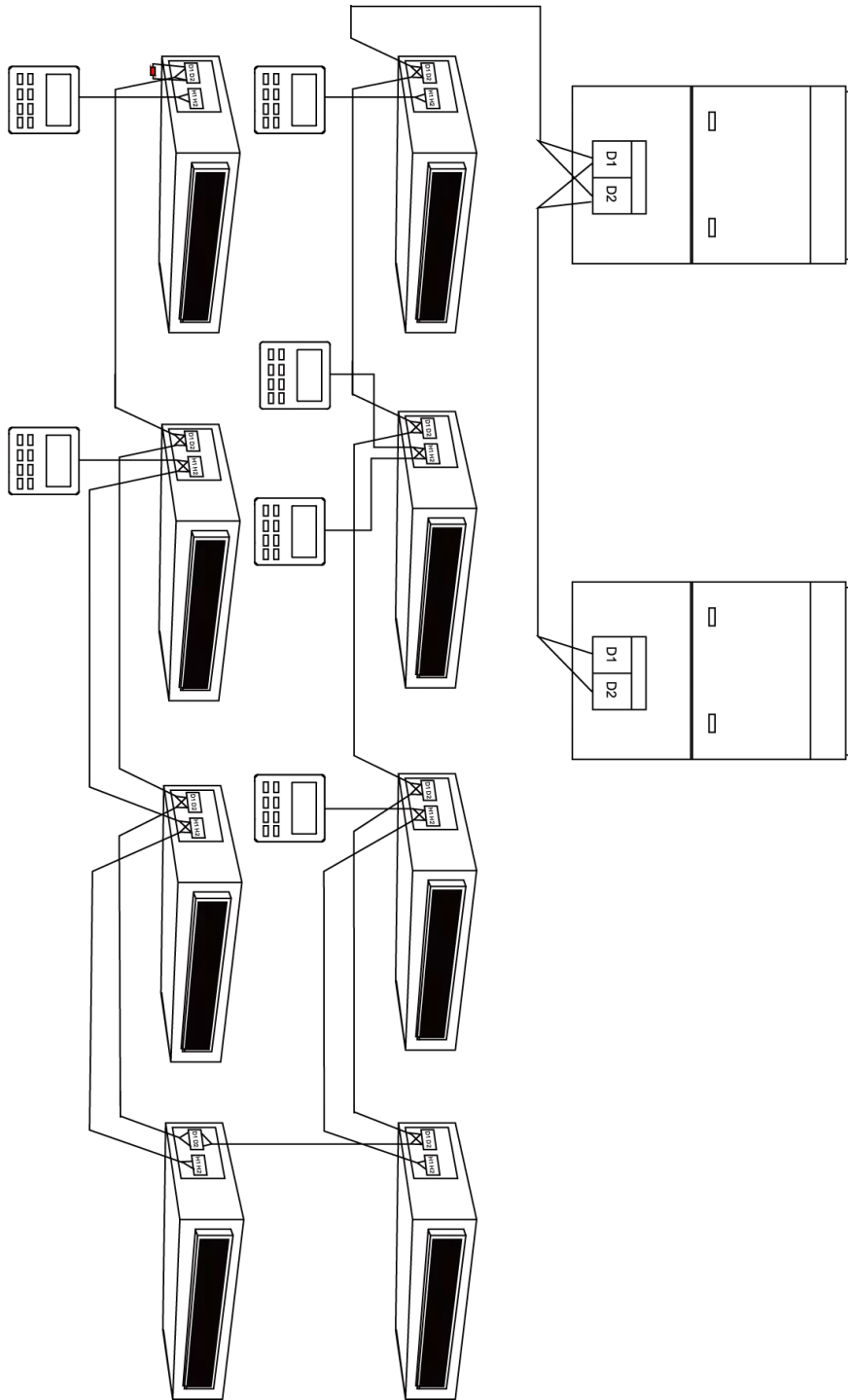

Figure 5-8



Notes:

- ① The type of indoor units must be the same if they are controlled by the same wired controller.
- ② When the indoor unit is controlled by two wired controllers, the addresses of the two wired controllers should be different through address setting. Address 1 is for main controller; Address 2 is for slave controller. Detailed settings please refer to the instruction manual of wired controller.

6 Function Setting

6.1 Statement on Linkage Function Setting

When several AHU-KITs are in parallel connection with one AHU, you must activate linkage function after installation for normal operation. Setting way is as below:

Step 1: Set group control IDU quantity

After making sure all AHU-KITs are energized, set AHU-KIT quantity through wired controller P14, detailed operation is as follows:

Under on or off status, press “Function” button for 5s to enter into the first level menu interface; Under parameter code “C00” status, (after pressing “Mode” button for three times”) press “Function” button for 5s to enter into the second level menu. The temperature area displays “P00”. Press “▲” and “▼” button can swing to the second level parameter code. Enter P14 engineer debugging interface, the top right corner of the interface will display “01”, which means the number of AHU-KIT under the control of wired controller is 1, short press “Mode”, and revise actual controlled AHU-KIT quantity through pressing “▲” and “▼” button, If two AHU-KITs are in parallel connection, please set 02, short press “Confirmed/Cancel” button, the setting is successful.

Step 2: Linkage function startup setting. The operation is as below:

Operate it according to above operation to enter P53 engineer debugging interface, the top right corner of the interface will display “00”, which means AHU-KIT linkage function is invalid; short press “Mode”, and conduct revision through pressing “▲” and “▼” button, set “01”, which means AHU-KIT linkage function is valid, short press “Confirmed/Cancel” button, the setting is successful.

6.2 Fresh air Function Setting

When it needs the fresh air indoor unit control, set the fresh air function with wired controller according to below method:

When the AHU adapter is energized, set the fresh air function with wired controller P60 by operation method as below:

Under on or off status, press “Function” button for 5s to enter into the first level menu interface. Under parameter code “C00” status, (after pressing “Mode” button for three consecutive times.) press “Function” button for 5s again to enter into the second level menu. The temperature area displays “P00”. Press “▲” and “▼” buttons can switch to the second level parameter code. After entering into P60 engineering debugging interface, the top right corner of interface will display “00”, which indicates it will control according to normal indoor unit. Short press “Mode” button and then press “▲” and “▼” buttons to modify it. Setting is “01”, which indicates fresh air is invalid. Short press “Confirm/Cancel” button, the setting is successful.



Note:

When setting the fresh air function, the air outlet temperature sensor must be installed.

6.3 Selection of Controller

6.3.1 Introduction to Functions

AHU-KIT adapter can be controlled via ASAMI wired controller, and can also be controlled via the third party controller by adjusting dial code, which can realize ON/OFF control, mode setting, temperature adjustment, feedback of unit operating status, etc.

6.3.2 Selection of Controller

AHU-KIT adapter can be controlled via ASAMI wired controller or the third party controller. Select the type of controller according to the first digit of “S2” dial code in the mainboard, for specific settings are as below:

S2				Type of controller
1	2	3	4	
0	0	0	0	ASAMI wired controller
1	0	0	0	Third party controller

Correctly dial the code switch to the right position, it is not allowed to dial to the middle position. Dialing the switch to “ON” direction refers to “0”, and the objective direction refers to “1”, as shown below (note: the black part is the dial lever):

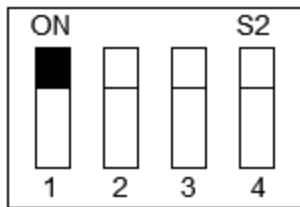

It means it has connected to Gree wired controller

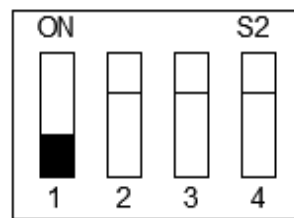

It means it has connected to the third party controller

Figure 6-1



Notes:

- ① Power supply must be cut off before adjusting any dial codes on the mainboard. Only when the adjustment is done can the power supply be reconnected, otherwise it may cause electric shock or invalid adjustment;
- ② Under the control mode of ASAMI wired controller, only control signal from ASAMI wired controller can be received, control signal of the third party controller cannot be received;
- ③ Under the control mode of the third party controller, only control signal from the third party's controller can be received, control signal of ASAMI wired controller cannot be received;
- ④ Even though the third party controller is selected, engineering setting of AHU-KIT adapter still needs to be set by ASAMI wired controller, such as “linkage function”, “fresh air function”, etc.;
- ⑤ When several sets of AHU-KIT adapter are simultaneously used, and one controller needs to control several sets of unit and the controller is the third party controller, the first bit of S2 dial code of adaptor for the third party's controller is adjusted as “1”, and the first bit of S2 dial code of other adaptor is adjusted as “0” and connected to ASAMI wired controller.

6.3.3 Connection between the Third Party Controller and AHU-KIT Adapter

AHU-KIT adapter is connected with the third party controller via dry contact analog quantity signal interface to realize control of unit, feedback of operating status and error protection, etc.

(1) Definition of interfaces

1) Signal from the third party controller to AHU-KIT adapter

Function	Type of interface	Wiring board	Wiring number	Description of signal
ON/OFF	Dry contact	XT5	4、5	When it is connected, it means ON; when it is disconnected, it means OFF
Cooling mode	Dry contact	XT5	6、7	When it is connected, it means cooling; when it is disconnected, it means not cooling
Heating mode	Dry contact	XT5	8、9	When it is connected, it means heating; when it is disconnected, it means not heating
Air supply mode	Dry contact	XT5	10、11	When it is connected, it means air supply; when it is disconnected, it means not air supply
Feedback of AHU error status	Dry contact	XT4、XT5	XT4(1)、XT5(1)	When it is connected, it means AHU has no error; when is it disconnected, it means AHU has error
Temperature setting	Analog voltage signal DC (0-10V)	XT5	2、3	Corresponding set temperature for input DC 0-10V is 16-30℃ (please see the setting of signal for temperature control)

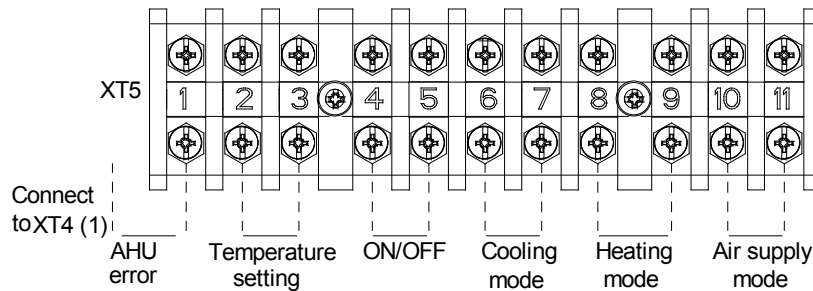

Figure 6-2

2) Signal from AHU-KIT adapter to the third party controller

Function	Type of interface	Wiring board	Wiring number	Description of signal
Operating status of AHU-KIT	Dry contact	XT4	2、3	When it is connected, it means the AHU-KIT is on; when it is disconnected, it means the AHU-KIT is off. (The input terminal cannot be connected to strong power and recommended voltage is 24V or less.)
Defrosting status of unit	Dry contact	XT4	4、5	When it is connected, it means the unit is in defrosting status; when it is disconnected, it means the unit is not in defrosting status. (The input terminal cannot be connected to strong power and recommended voltage is 24V or less.)
Error status of ODU and AHU-KIT	Dry contact	XT4	6、7	When it is connected, it means the unit has error; when it is disconnected, it means the unit is normal. (The input terminal cannot be connected to strong power and recommended voltage is 24 or less.)

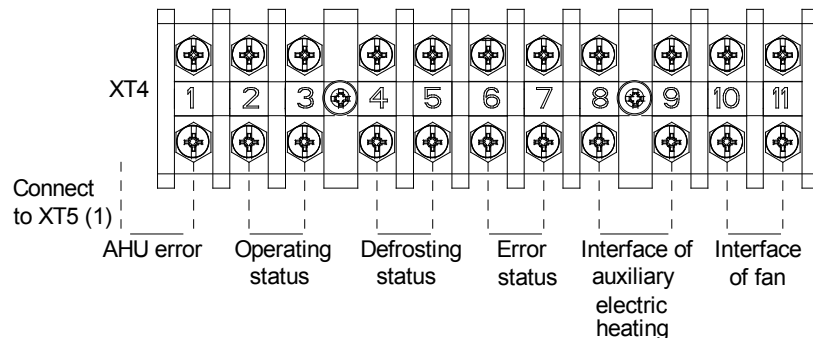

Figure 6-3

(2) Definition for input signal of temperature setting

AHU-KIT adapter provides the relation of direct and inverse ratio between DC 0-10V input voltage signals of and the corresponding set temperature. Select the direct and inverse ratio relation between the input voltage and the corresponding set temperature according to the second bit of “S2” dial code on the mainboard. The specific settings are as below:

S2				Relation between input voltage and set temperature
1	2	3	4	
1	0	0	0	Direct ratio between input voltage and set temperature
1	1	0	0	Inverse ratio between input voltage and set temperature

1) Setting of dial code

Correctly dial the code switch to the right position, it is not allowed to dial to the middle position. Dialing the switch to “ON” direction refers to “0”, and the objective direction refers to “1”, as shown below (note: the black part is the dial lever):

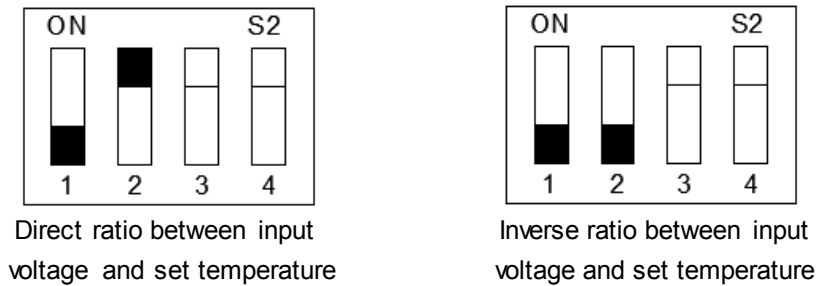

Figure 6-4

2) Definition of input voltage signal

When the second bit of “S2” dial code is dialed to “0”, that is, the input voltage and set temperature is direct ratio, then the relation between input voltage and set temperature is as below:

Analog quantity input DC 0~10V			Set temperature (℃) Cooling	Set temperature (℃) Heating
Standard value (V)	Voltage range (V)			
	Minimum value	Maximum value		
0.5	0	1.15	Default value	Default value
1.5	1.35	1.65	16	16
2	1.85	2.15	17	17
2.5	2.35	2.65	18	18
3	2.85	3.15	19	19
3.5	3.35	3.65	20	20
4	3.85	4.15	21	21
4.5	4.35	4.65	22	22
5	4.85	5.15	23	23
5.5	5.35	5.65	24	24
6	5.85	6.15	25	25
6.5	6.35	6.65	26	26
7	6.85	7.15	27	27
7.5	7.35	7.65	28	28
8	7.85	8.15	29	29
8.5	8.35	8.65	30	30
9.5	8.85	10	Default value	Default value

When the second bit of “S2” dial code is adjusted to “1”, that is, input voltage and set temperature is inverse ratio, then the relation between input voltage and set temperature is as below:

Analog quantity input DC 0~10V			Set temperature (℃) Cooling	Set temperature (℃) Heating
Standard value (V)	Voltage range (V)			
	Minimum value	Maximum value		
0.5	0	1.15	Default value	Default value
1.5	1.35	1.65	30	30

Standard value (V)	Analog quantity input DC 0~10V		Set temperature (℃) Cooling	Set temperature (℃) Heating
	Voltage range (V)			
	Minimum value	Maximum value		
2	1.85	2.15	29	29
2.5	2.35	2.65	28	28
3	2.85	3.15	27	27
3.5	3.35	3.65	26	26
4	3.85	4.15	25	25
4.5	4.35	4.65	24	24
5	4.85	5.15	23	23
5.5	5.35	5.65	22	22
6	5.85	6.15	21	21
6.5	6.35	6.65	20	20
7	6.85	7.15	19	19
7.5	7.35	7.65	18	18
8	7.85	8.15	17	17
8.5	8.35	8.65	16	16
9.5	8.85	10	Default value	Default value



Notes:

- ① If the AHU-KIT adapter is installed in the position with strong electromagnetic interference, the voltage signal may be impacted, which should be shielded to ensure the accuracy of input voltage signal.
 - ② When the AHU-KIT detects that the corresponding set temperature of voltage is “default value”:
 - a) If the unit is under cooling mode, the default set temperature is 26℃ .
 - b) If the unit is under heating mode, the default set temperature is 20℃ .
 - c) If the unit is under air supply mode, the default set temperature is 26℃ .
 - ③ Input voltage should not be over 10V, otherwise it may damage the controller.
- (3) Diagram for integrated connection of system

When an AHU adapter connects to one set of air conditioner and adopts the third party controller, the connection is shown as below:

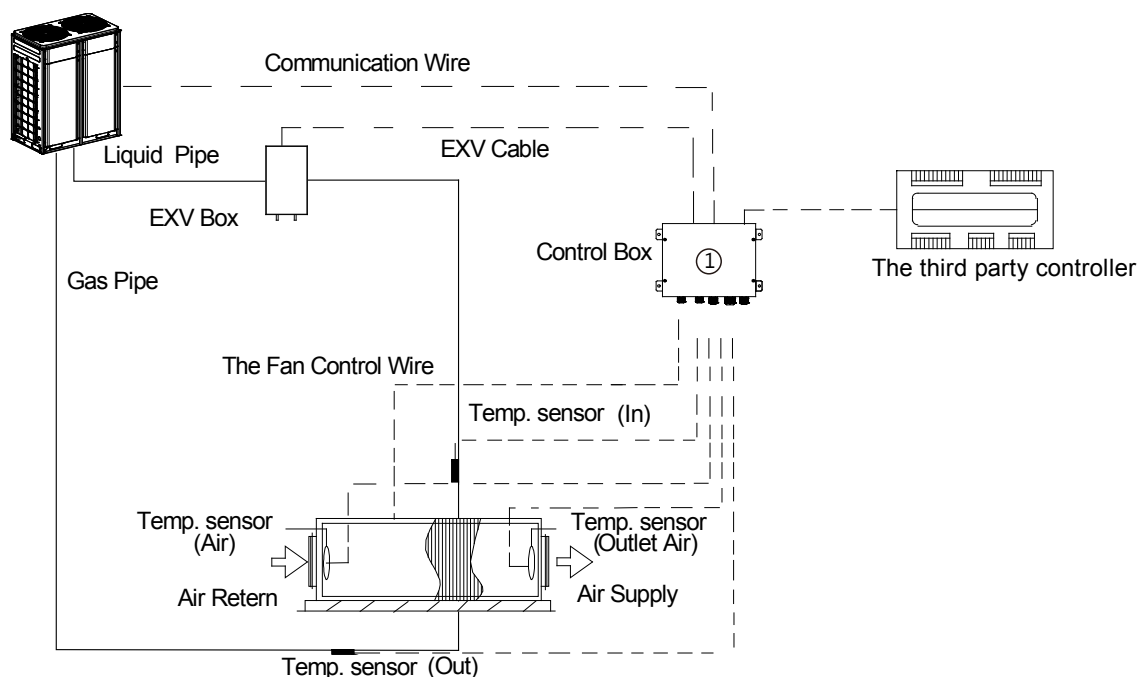

Figure 6-5

When several sets of AHU adapters ($n \leq 3$) connect in parallel and connect to one set of air conditioner,

the diagram is shown as below:

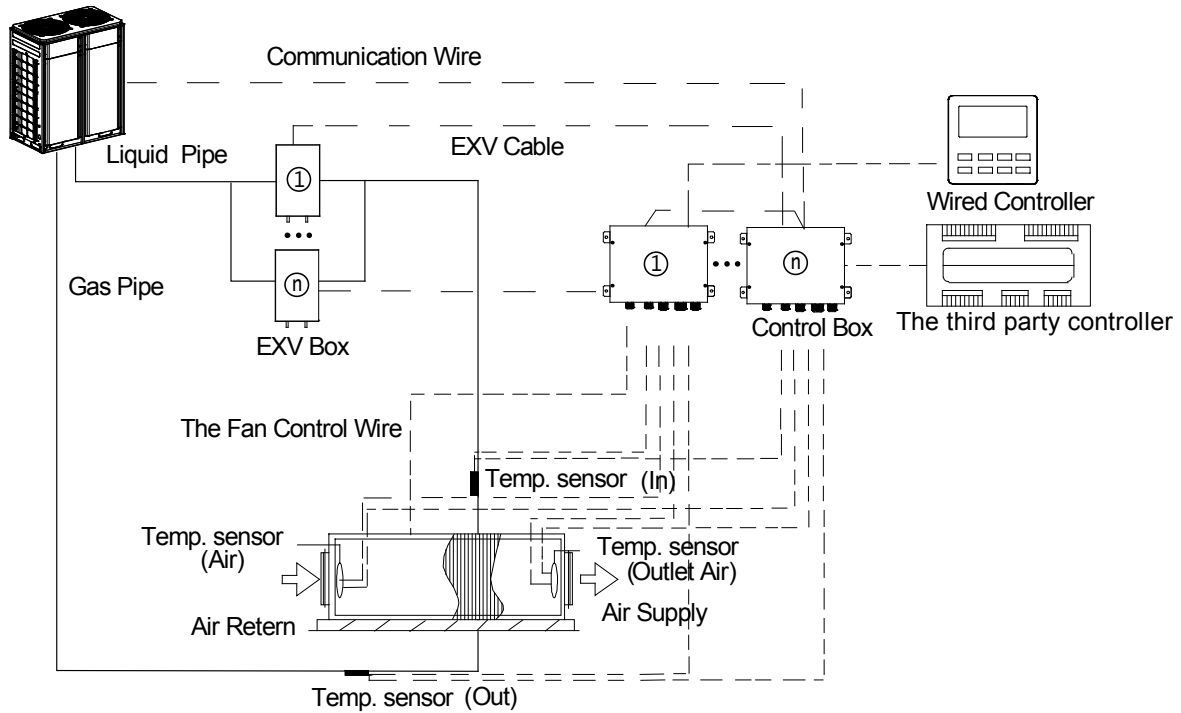

Figure 6-6



Notes:

- ① Length of connection wire between the third party controller to AHU-KIT adapter should not be over 15 meters.
- ② When several sets of AHU-KIT adapter connect in parallel and adopts the third party controller, the first bit of S2 dial code of adapter connected to the third party controller is adjusted to “1”, and the first bit of S2 dial code of the other adapters is adjusted to “0” and connect to ASAMI wired controller.
- ③ When AHU-KIT adapter adopts the third party controller, AHU-KIT adapter needs to connect to ASAMI wired controller while setting the master IDU. The methods for setting the master IDU through the wired controller are as follows:
 - a) Step 1: Set an IDU to power-off status.
 - b) Step 2: Press and hold the "MODE" button on the wired controller for more than five seconds.
 - c) Step 3: Check whether the setting is successful. If it is, "MASTER" on the wired controller will be on. Otherwise, repeat steps 1 and 2.

7 Operation and Maintenance

7.1 Before Operation



Notes:

- ① Before initiating operation, please read the operation manuals of outdoor unit, AHU-KIT unit and the air handling unit carefully.
- ② Refer to the installation manuals of the outdoor unit, AHU-KIT unit and the remote controller about settings of unit.

7.2 Test Operation

Before executing "test operation" as well as before operating the unit, you must check the following:

- (1) Refer to the section of "For the following items, take special care during construction and check after installation is finished".
- (2) Ensure the construction of refrigerant piping, drain piping and electric wiring are finished.
- (3) Check everything written in the installation manuals of the outdoor unit, AHU-KIT unit and the air handling unit.
- (4) Open the gas side stop valve.
- (5) Open the liquid side stop valve.

Executing the test operation:

- (1) Referring to the manuals of the outdoor unit and the air handling unit.
- (2) Confirm that the fan of the air handling unit is ON.

7.3 Routine Maintenance



Warning:

- ① Only a qualified service person is allowed to perform maintenance.
- ② Before obtaining access to terminal devices, all power supply circuits must be interrupted.
- ③ Water or detergent may deteriorate the insulation of electronic components and result in burn-out of these components.
- ④ Stand at solid table when cleaning the unit.
- ⑤ Do not clean the unit with hot water whose temperature is higher than 45°C to prevent fade or deformation.
- ⑥ Clean the filter with a wet cloth dipped in neutral detergent.
- ⑦ Please contact after-sales service staff if there is abnormal situation.

7.3.1 Maintenance before the Seasonal Use

- (1) Check if the air inlet and air outlet of indoor and outdoor unit are blocked.
- (2) Check if securely grounded.
- (3) Check if all the power cord and communication cable are securely connected.
- (4) Check if any error code displayed after energized.

7.3.2 Maintenance after the Seasonal Use

- (1) Set the unit in fan mode for half a day in a sunny day to dry the inner part of unit.
- (2) When the unit won't be used for a long time, please cut off power supply for energy saving; the characters on the wired controller screen will disappear after cutting off the power supply.

7.4 Disposal Requirements

Dismantling of the unit, treatment of the refrigerant, of oil and of other parts must be done in accordance with relevant local and national legislation.

8 Table of Error Codes for Indoor Unit

Error Code	Content	Error Code	Content	Error Code	Content
L0	Indoor Unit Error	L9	Quantity Of Group Control Indoor Units Setting Error	d8	Water Temperature Sensor Error
L1	Error From External Feedback	LA	Indoor Units Incompatibility Error	d9	Jumper Cap Error
L2	E-heater Protection	LH	Low Air Quality Warning	dA	Indoor Unit Hardware Address Error
L3	Water Full Protection	LC	Outdoor-Indoor Incompatibility Error	dH	Wired Controller PC- Board Error
L4	Wired Controller Power Supply Error	d1	Indoor Unit PC- Board Error	dC	Capacity DIP Switch Setting Error
L5	Anti-Frosting Protection	d3	Ambient Temperature Sensor Error	dL	Outlet Air Temperature Sensor Error
L6	Model Conflict	d4	Inlet Piping Temperature Sensor Error	dE	Indoor Unit CO ₂ Sensor Error
L7	No Master Indoor Unit Error	d6	Outlet Piping Temperature Sensor Error	C0	Communication Error
L8	Power Insufficiency Protection	d7	Humidity Sensor Error	AJ	Filter Cleaning Reminder
yJ	No Model Setting Signal Wire	yP	Multi-Model Conflict	yU	No Temperature Setting Signal Wire
db	Special Code: Field Debugging Code				

9 Troubleshooting

If your air conditioner is not working well, please check the following table first before asking for service:

Phenomenon	Troubleshooting
The unit can't start	<ul style="list-style-type: none"> ① No power supply. ② Circuit breaker is tripped because of current leakage. ③ Circuit voltage is too low. ④ ON/OFF key sets at the stop position. ⑤ Failure in control system.
The unit stops after running for a while	<ul style="list-style-type: none"> ① Obstacle in front of the condenser. ② Abnormal operation of the control system. ③ Outdoor temperature is higher than 43°C when cooling mode is used.
Poor cooling effect	<ul style="list-style-type: none"> ① Air filter is dirty or blocked. ② Too many heating sources or people in the room. ③ Doors or windows are open. ④ Obstacle at the air intake and outlet of the unit. ⑤ Setting temperature is too high or refrigerant is insufficient (e.g. refrigerant leakage). ⑥ Poor performance of the indoor temperature sensor.
Poor heating effect	<ul style="list-style-type: none"> ① Air filter is dirty or blocked. ② Doors or windows are open. ③ Wrong temperature setting (too low). ④ Refrigerant leakage. ⑤ Outdoor temperature is lower than -5°C. ⑥ Abnormal operation of the control system.
Indoor fan doesn't start up during heating	<ul style="list-style-type: none"> ① Improper location of tube sensor. ② The tube sensor inserts not well. ③ The wiring of tube sensor is broken. ④ Electricity leakage of capacitor.



Notes:

If air conditioner still fails to work normally after checking and handling as described above, please stop using it immediately and contact local service center for assistance.

ADDITIONAL SETTINGS FOR AHU KIT

1. We make the connection of the Ahu kit according to the standard GREE scheme, the sensors are installed as shown below.

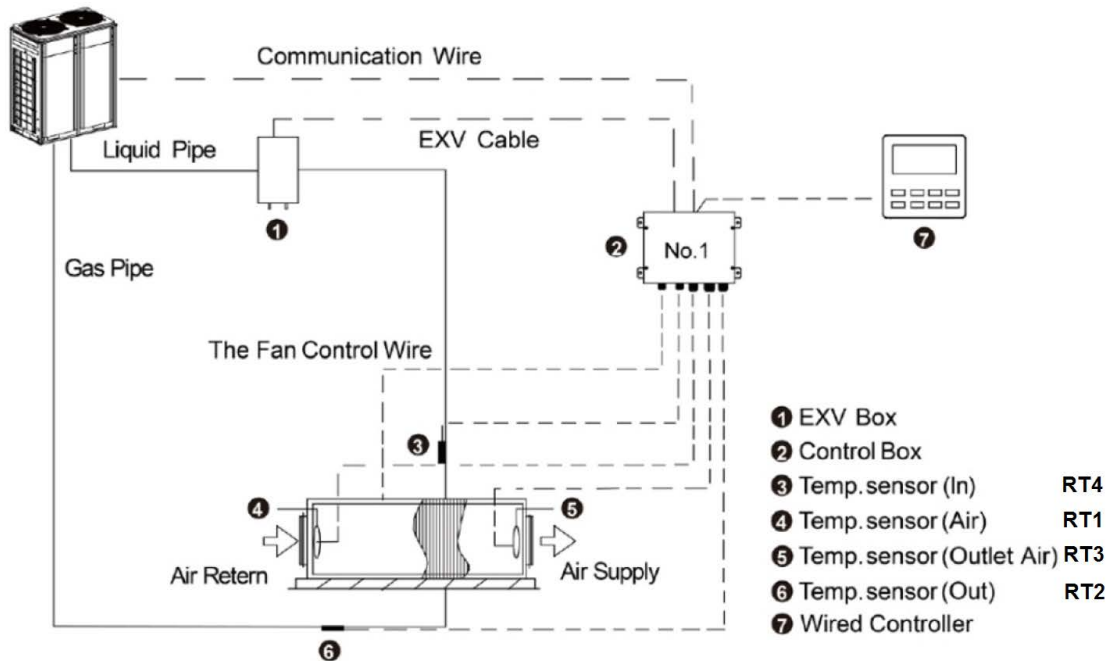

2. P60 parameter must be 01 - activates fresh air mode.

When it needs the fresh air indoor unit control, set the fresh air function with wired controller according to below method:

When the AHU adapter is energized, set the fresh air function with wired controller P60 by operation method as below:

Under on or off status, press "Function" button for 5s to enter into the first level menu interface. Under parameter code "C00" status, (after pressing "Mode" button for three consecutive times.) press "Function" button for 5s again to enter into the second level menu. The temperature area displays "P00". Press "▲" and "▼" buttons can switch to the second level parameter code. After entering into P60 engineering debugging interface, the top right corner of interface will display "00", which indicates it will control according to normal indoor unit. Short press "Mode" button and then press "▲" and "▼" buttons to modify it. Setting is "01", which indicates fresh air is valid. Short press "Confirm/Cancel" button, the setting is successful.