



# humiFog Touch

pumping station



## INSTALLATION MANUAL

→ **LEGGI E CONSERVA  
QUESTE ISTRUZIONI** ←  
**READ AND SAVE  
THESE INSTRUCTIONS**

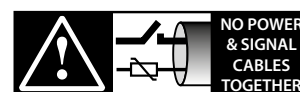

**READ CAREFULLY IN THE TEXT!**

**humiFog Touch**

+0300113EN - ENG

Up to date version available on

[www.carel.com](http://www.carel.com)



## GENERAL WARNINGS



**FAILURE TO CAREFULLY HEED THE WARNINGS SHOWN IN THIS MANUAL COULD LEAD TO FIRE OR EXPLOSION AND CONSEQUENT DAMAGE TO PROPERTY, INJURY OR DEATH.**

CAREL Industries humidifiers are advanced products, whose operation is specified in the technical documentation supplied with the product or can be downloaded, even prior to purchase, from the website [www.carel.com](http://www.carel.com). Each CAREL product, in relation to its advanced level of technology, requires setup/configuration/programming to be able to operate in the best possible way for the specific application. Failure to complete such operations, which are required/indicated in the user manual, may cause the final product to malfunction; CAREL accepts no liability in such cases. The customer (manufacturer, developer or installer of the final equipment) accepts all liability and risk relating to the configuration of the product in order to reach the expected results in relation to the specific final installation and/or equipment. CAREL may, based on prior agreements, act as a consultant for the installation/commissioning/use of the unit, however in no case does it accept liability for the correct operation of the humidifier and the final installation if the warnings or suggestions provided in this manual or in other product technical documents are not heeded. In particular, as well as observing the above warnings and suggestions, the following warnings must be observed for correct use of the product:

**ELECTRIC SHOCK HAZARD:** the humidifier contains live electrical components. Disconnect the mains power supply before accessing inside parts or during maintenance and installation.

**WATER LEAK HAZARD:** the humidifier automatically and constantly fills/drains certain quantities of water. Malfunctions in the connections or in the humidifier may cause leaks.

## CAUTION

The installation of the product must include an earth connection, using the special yellow-green terminal available in the humidifier.

Caution:

- Disconnect the appliance from the mains power supply before accessing any internal parts.
- Environmental and power supply conditions must conform to the values specified on the product rating labels.
- The product is designed exclusively to humidify rooms either directly or through distribution systems (ducts).
- Only qualified personnel who are aware of the necessary precautions and able to perform the required operations correctly may install, operate or carry out technical service on the product.
- Only water with the characteristics indicated in this manual must be used to produce the spray.
- All operations on the product must be carried out according to the instructions provided in this manual and on the labels applied to the product. Any uses or modifications that are not authorised by the manufacturer are considered improper. CAREL declines all liability for any such unauthorised use.
- Do not attempt to open the appliance in any way other than described in the manual.
- Observe the standards in force in the place where the humidifier is installed.
- The appliance is not intended for use by persons (including children) with reduced physical, sensory or mental capabilities, or lack of experience and knowledge, unless they have been given supervision or instruction concerning use of the appliance by a person responsible for their safety.
- Do not install and use the product near objects that may be damaged when in contact with water (or condensate). CAREL declines all liability for direct or indirect damage following water leaks from the humidifier.
- Do not use corrosive chemicals, solvents or aggressive detergents to clean the inside and outside parts of the humidifier, unless specifically indicated in the user manual.

- Do not drop, hit or shake the humidifier, as the inside parts and the linings may be irreparably damaged,

CAREL adopts a policy of continual development. Consequently, CAREL reserves the right to make changes and improvements to any product described in this document without prior warning. The technical specifications shown in the manual may be changed without prior warning. The liability of CAREL in relation to its products is specified in the CAREL general contract conditions, published on the website [www.carel.com](http://www.carel.com) and/or by specific agreements with customers; specifically, to the extent where allowed by applicable legislation, in no case will CAREL, its employees or subsidiaries/affiliates be liable for any lost earnings or sales, losses of data and information, costs of replacement goods or services, damage to things or people, downtime or any direct, indirect, incidental, actual, punitive, exemplary, special or consequential damage of any kind whatsoever, whether contractual, extra-contractual or due to negligence, or any other liabilities deriving from the installation or use of the product, even if CAREL or its subsidiaries/affiliates are warned of the possibility of such damage.

## DISPOSAL

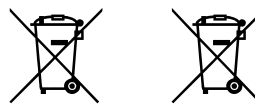

Fig. 1

Fig. 2

PLEASE READ AND KEEP.

WITH REFERENCE TO EUROPEAN UNION DIRECTIVE 2012/19/EU ISSUED ON 4 JULY 2012 AND RELATED NATIONAL LEGISLATION, PLEASE NOTE THAT:

- Waste Electrical and Electronic Equipment (WEEE) cannot be disposed of as municipal waste but must be collected separately so as to allow subsequent recycling, treatment or disposal, as required by law;
- users are required to take Electrical and Electronic Equipment (EEE) at end-of-life, complete with all essential components, to the WEEE collection centres identified by local authorities. The directive also provides for the possibility to return the equipment to the distributor or retailer at end-of-life if purchasing equivalent new equipment, on a one-to-one basis, or one-to-zero for equipment less than 25 cm on their longest side;
- the equipment may contain hazardous substances: the improper use or incorrect disposal of such may have negative effects on human health and on the environment;
- the symbol (crossed-out wheeled bin, see Figure 1), if shown on the product or on the packaging, indicates that the equipment must be disposed of separately at end-of-life;
- if at end-of-life the EEE contains a battery (Figure 2), this must be removed following the instructions provided in the user manual before disposing of the equipment. Used batteries must be taken to appropriate waste collection centres as required by local regulations;
- in the event of illegal disposal of electrical and electronic waste, the penalties are specified by local waste disposal legislation.

**Warranty on materials:** 2 years (from production date, excluding consumables).

**Approval:** the quality and safety of CAREL products are guaranteed by the ISO 9001 certified design and production system, as well as the



Intertek



WaterMark

, and marks.



# Index

- 1. PURPOSE OF THE MANUAL ..... 7**
- 2. HOW TO READ THE MANUAL ..... 7**
- 3. General safety information and instructions ..... 8**
  - 3.1 Intended use.....8
  - 3.2 General safety instructions .....8
  - 3.3 Personal protective equipment.....9
- 4. Introduction..... 10**
  - 4.1 Components.....10
  - 4.2 Air handling unit (AHU).....10
  - 4.3 Pumping station.....13
  - 4.4 Opening the packaging .....13
  - 4.5 Positioning.....14
  - 4.6 Opening.....14
  - 4.7 Identification.....14
  - 4.8 Structure.....15
  - 4.9 Accessories.....15
- 5. Installation notes ..... 18**
  - 5.1 Network connection.....18
  - 5.2 Distribution system .....19
  - 5.3 Functional diagrams - room.....19
  - 5.4 Backup and rotation.....21
- 6. Installation ..... 22**
  - 6.1 Water connections.....22
  - 6.2 Feedwater.....23
  - 6.3 Electrical connections.....23
  - 6.4 Control connections.....24
  - 6.5 Solenoid valve connections.....25
  - 6.6 Inputs and outputs.....25
- 7. Maintenance ..... 27**
  - 7.1 Routine maintenance.....27
  - 7.2 One-off service and repairs .....27
  - 7.3 Pump maintenance.....28
- 8. Technical data ..... 29**
  - 8.1 Technical specifications.....29
  - 8.2 Terminal tightening torque.....29
  - 8.3 Fuse chart.....29
- 9. Checklist ..... 30**
- 10. ANNEXES ..... 31**
  - Annex A: Wiring diagrams.....31
  - Annex B: Accessories and spare parts kits.....33



# 1. PURPOSE OF THE MANUAL

This manual contains instructions for the installation, use and maintenance of the models of humiFog unit manufactured by:

CAREL INDUSTRIES  
Via dell'Industria, 11, 35020  
Brugine - Padova (Italy)  
Tel. (+39) 049.9716611 - Fax (+39) 049.9716600  
e-mail: [carel@carel.com](mailto:carel@carel.com) - [www.carel.com](http://www.carel.com)

# 2. HOW TO READ THE MANUAL

The manual is divided into chapters and paragraphs. Each paragraph is a sub-level of the corresponding chapter. References to headings or paragraphs are indicated by the abbreviation "Chap." or "Par." followed by the number.

Example: "Chap. 2" or "Par. 2.1".

The figures in this manual are numbered consecutively according to the corresponding chapter, for example Figure 1.c is the third figure in chapter one. References to the figures are indicated by the abbreviation "Fig." followed by the number. Example: "Fig. 1.c".

The components shown in the figures are marked with numbers. A reference to component 1 in figure 2, chapter 3 will be indicated as follows: "See 1 - Fig. 3.b" or simply "(1 - Fig. 3.b)".



## IMPORTANT

The figures shown in this manual are purely indicative. The actual components may vary from those illustrated. If in doubt, contact an authorised service centre.

In addition to the instructions for installation, use and maintenance, this manual contains safety information that requires special attention. This information is denoted by the symbols described below:



## DANGER

Failure to comply with this warning will lead to an imminently hazardous situation which, if not avoided, will result in death or serious injury.



## WARNING

Failure to comply with this warning will lead to a potentially hazardous situation which, if not avoided, could result in death or serious injury.



## CAUTION

Failure to comply with this warning will lead to a potentially hazardous situation which, if not avoided, may result in minor or moderate injury.



## IMPORTANT

Failure to comply with this warning will lead to a potentially hazardous situation which, if not avoided, could cause minor damage to the unit.



**Notice:** provides supplementary information to the above safety instructions.

## 3. GENERAL SAFETY INFORMATION AND INSTRUCTIONS

### 3.1 Intended use

humiFog is a high pressure adiabatic humidification system for humidity control and evaporative cooling. It can be used both to condition the air in an AHU (air handling unit), and for direct humidification or cooling in rooms.



**IMPORTANT:** the product must only be used for its intended purpose, as envisaged by CAREL. CAREL declines all liability, both contractual and extra-contractual, for any damage to people, animals or things due to installation, control or maintenance errors or improper use.

### 3.2 General safety instructions

When using products that require electricity and a source of high-pressure water, a number of fundamental safety rules need to be observed, including:

- The appliance must not be used by children or people with reduced physical, sensory or mental capabilities, or people lacking the necessary experience or knowledge or who are not familiar with the operating instructions.
- People without specific qualifications and skills must not use the pumping station.
- People must not come into contact with the appliance if barefoot or any of the parts of their body are wet.
- No technical or cleaning operations are allowed until the appliance has been isolated from the power supply by moving the main system switch to "off" and the main switch on the appliance to "OFF".
- The safety and control devices must never be adjusted without the manufacturer's authorisation.
- The pictograms and labels affixed to the pumping station must not be removed. These must remain legible and the corresponding instructions must be observed at all times. If they are no longer legible, they must be replaced with equivalent pictograms or safety labels.
- The water connections must never be loosened during operation. Improperly secured pipes or hoses may detach without warning, resulting in injury.
- Do not block or obstruct the water drain.
- Do not pull, disconnect or twist the electrical cables coming out of the appliance, even when this is disconnected from the mains power supply.
- Never expose the appliance to the elements. It is designed for indoor use only.
- Do not dispose of the packaging material in the environment and keep it out of the reach of children, as it is a potential hazard. It must be disposed of in accordance with current legislation.
- Do not activate the pumping station without it being adequately supplied with water.
- The customer is responsible for ensuring that the humidification system complies with local guidelines on occupational health and safety and prevention of bacterial proliferation.
- In the event of water leaks, disconnect the pumping station from the power supply, shut off the water supply and promptly notify CAREL's Technical Service or other professionally qualified personnel.
- Periodically check that the water circuit operating pressure is above 1 bar and below than the maximum limit specified for the appliance. Otherwise, contact CAREL's Technical Service or other professionally qualified personnel.
- If the pumping station is not used for an extended period, the following operations need to be carried out:
  - Turn the main switch on the appliance to "OFF"
  - Turn the main system switch to "off"
  - Close the system water taps
  - Empty the system if there is the risk of freezing.
- This instruction manual is an integral part of the appliance and consequently must be kept with care and must ALWAYS accompany the pumping station even if it is transferred to another owner or installed in another system. If damaged or loss, another copy can be ordered from CAREL's local Technical Service.
- Read this instruction manual read carefully to ensure proper and safe installation, operation and maintenance of the appliance. The owner must be adequately informed and trained on how to use the appliance. Users must be familiar with all the information needed for safe operation of the system.
- Before connecting the pumping station to the water and power supply, it can be exposed to temperatures between -10°C and 40°C. Once commissioned, it can be exposed to temperatures between 5°C and 40°C.
- Periodically check that the water drains are not blocked.



### 3.3 Personal protective equipment

---



**DANGER:** strictly follow the instructions provided in the manual.

Personal protective equipment (PPE) means any equipment intended to be worn and kept by workers in order to protect themselves against one or more risks likely to threaten their health or safety during work, as well as any device or accessory intended for this purpose.

All PPE described in this manual are intended to protect personnel from health and safety risks.

Below is a list of personal protective equipment to be used and the procedures to be adopted to protect workers from the residual risks that exist during the various phases of the humidifier's life cycle.



**GLOVES TO PROTECT AGAINST PHYSICAL ELEMENTS:**

these must protect the person's hands against cuts, abrasion and heat.

**NON-SLIP SAFETY FOOTWEAR:** these must prevent falls on slippery surfaces and protect the person's feet from impact, crushing and puncture wounds.

**SAFETY HARD HAT:** this must protect the person's head against bumps or material accidentally falling from above.

**SAFETY GLASSES:** these must protect the person's eyes from all risks due to contact with hazardous substances or materials.

**PROTECTIVE MASK:** this protects the wearer's respiratory tract against all risks associated with the inhalation of dangerous substances.

**PROTECTIVE CLOTHING:** this guarantees the body adequate protection against thermal and chemical agents.

**EARMUFFS:** these must attenuate noises that would otherwise be harmful to the person's hearing.

**INSTRUCTION MANUAL:** this must be referred to whenever necessary, in order to avoid adopting unsafe procedures.

# 4. INTRODUCTION

## 4.1 Components

- Pumping station, comprising the system pump and the electrical panel;
- zone electrical panel;
- distribution system and droplet separator for humidification in air handling units;
- blower unit for in-room humidification.

The range includes the pumping station in the humiFog multizone and humiFog multizone Touch versions, which differ in terms of the components supplied, the accessories available and the different system configuration modes.

The system can comprise:

- single zone: 1 pumping station with 1 atomisation system;
- multizone: 1 pumping station that supplies up to 12 independent atomisation systems.



**Notice:**

- to connect the pumping station to the blowers, use the water circuit assemblies and electrical panels supplied separately by Carel (see the list of accessories);
- to facilitate commissioning, plates already equipped with electrical connectors are available for simply and quickly connecting the electrical panels to the solenoid valves on the distribution manifolds.

The following diagrams provide an overview of the systems that can be implemented.

## 4.2 Air handling unit (AHU)

Internal rack valves

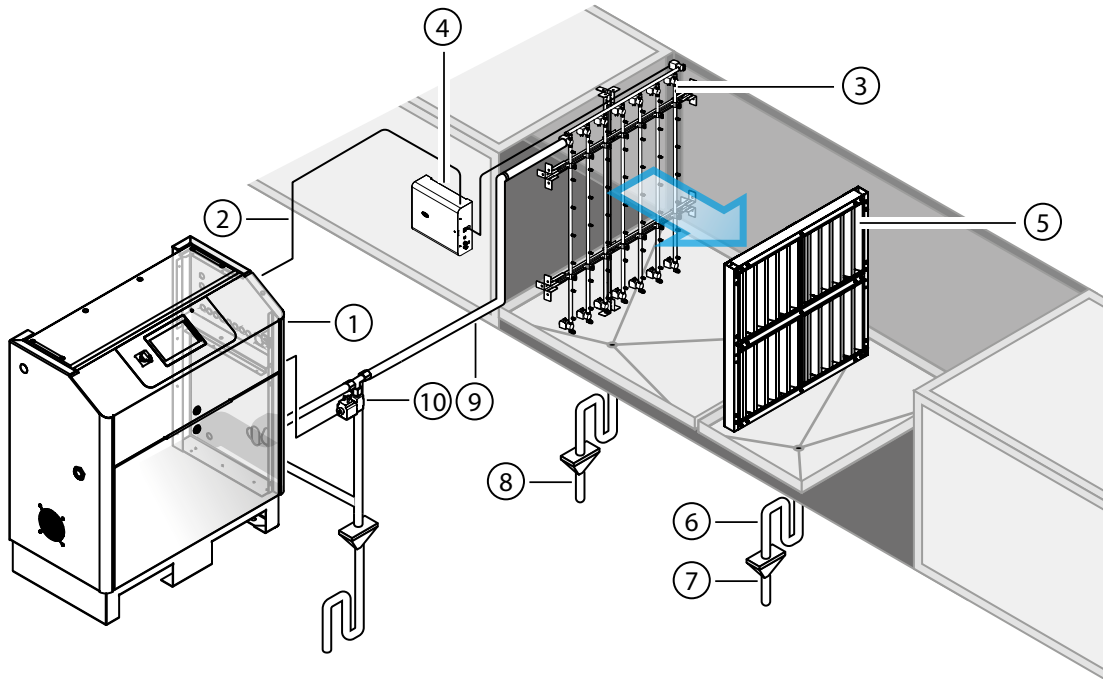

Fig. 4.a

Ref.	Description
1	Pumping station
2	Electrical cables
3	Distribution manifolds
4	Zone-electrical panel
5	Droplet separator
6	Drain trap
7	Open funnel drain (after droplet separator)
8	Open funnel drain (before droplet separator)
9	High pressure water line
10	Line drain valve

Tab. 4.a

Multizone

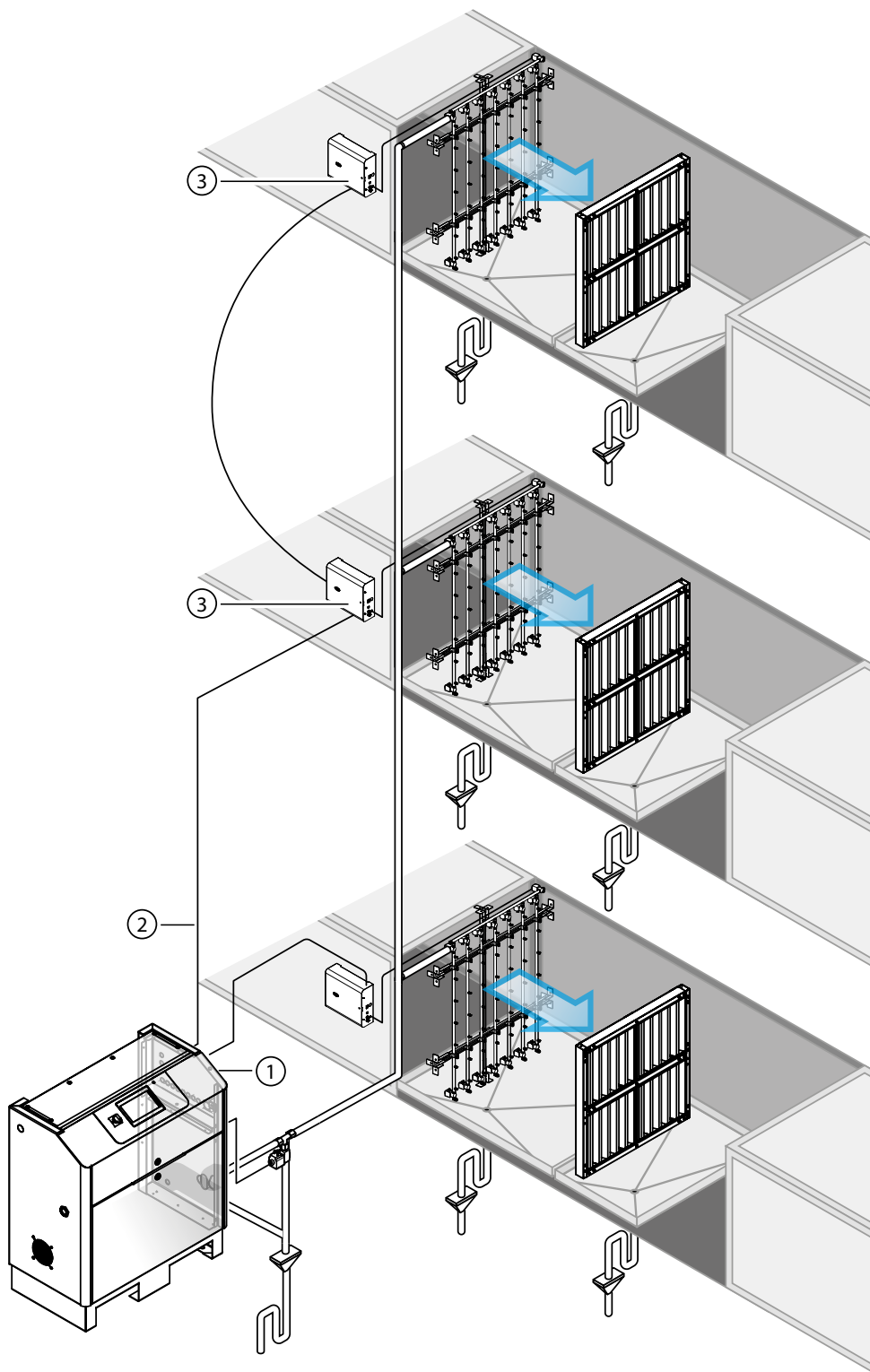

Fig. 4.b

Ref.	Description
1	Pumping station
2	Ethernet cable
3	Zone electrical panel

Tab. 4.b



**Notice:** for the Ethernet connection from the pumping station to the zone electrical panels, see "Installation notes".

### 4.2.1 Room

Single zone

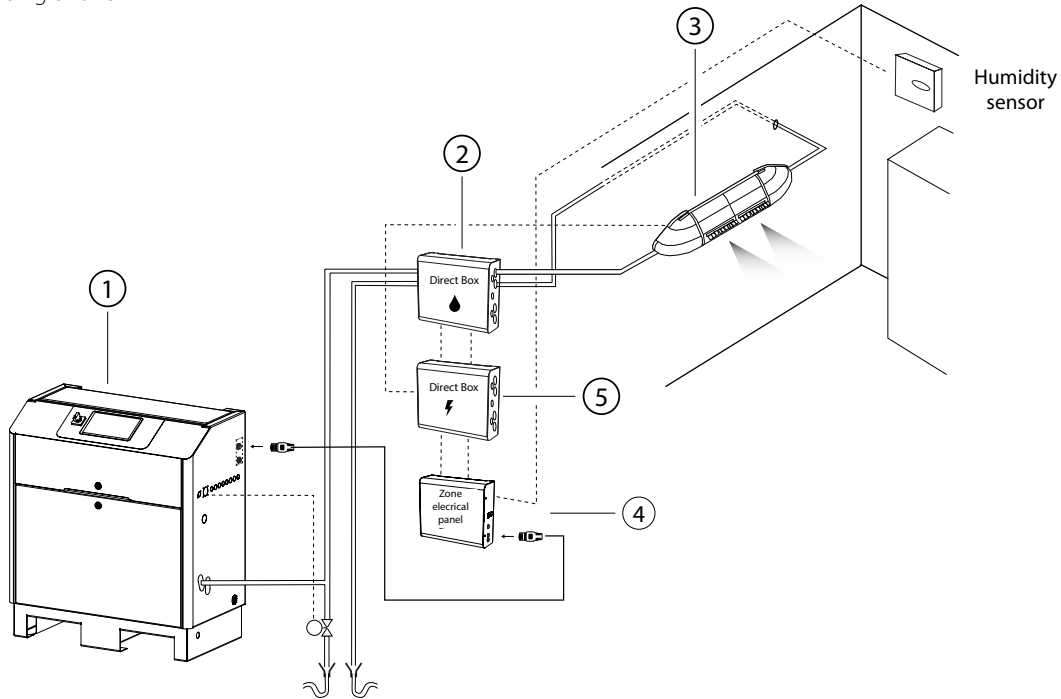

Fig. 4.c

Multizone

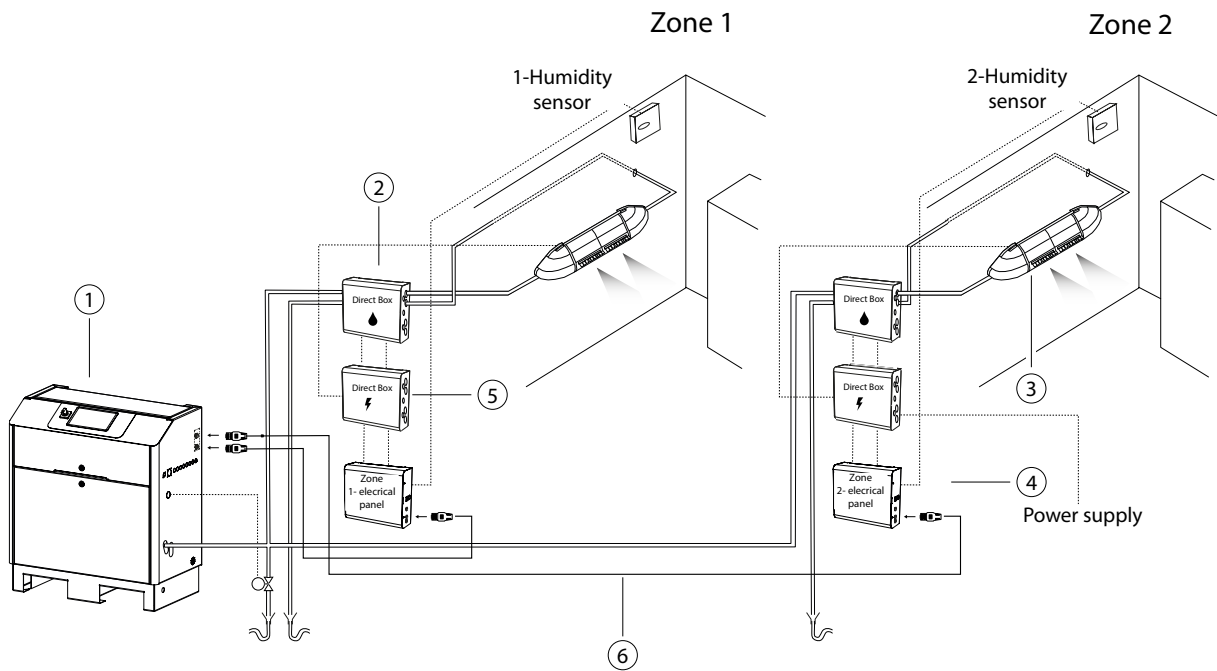

Fig. 4.d

Ref.	Description
1	Pumping station
2	Directbox hydraulic
3	Blower unit
4	Zone electrical panel
5	Directbox electric
6	Ethernet cable

Tab. 4.c

### 4.3 Pumping station

#### 4.3.1 Part numbers

humiFog multizone Touch models

U	A	*	*	*	*	*	5	0	*
Range	Flow-rate kg/h	Model	Power supply and approval			Revision no.	Customisation	Pump type	
UA:	150: 150 kg/h	1: humiFog	2: 230 Vac 50/60 Hz, 1~, UL			5: Fifth revision	0: Carel	0: Brass	
humiFog	300: 300 kg/h	multizone	U: 208 Vac 50/60 Hz, 1~, UL					1: Stainless steel	
	500: 500 kg/h	Touch	M: 460 Vac 50/60 Hz, 3~, UL					2: Silicone-free stainless steel	
	800: 800 kg/h								
	1K2: 1200 kg/h								

Tab. 4.a



Notice: in accordance with the requirements of UL998 in the most recent edition.

#### 4.3.2 Dimensions - inches

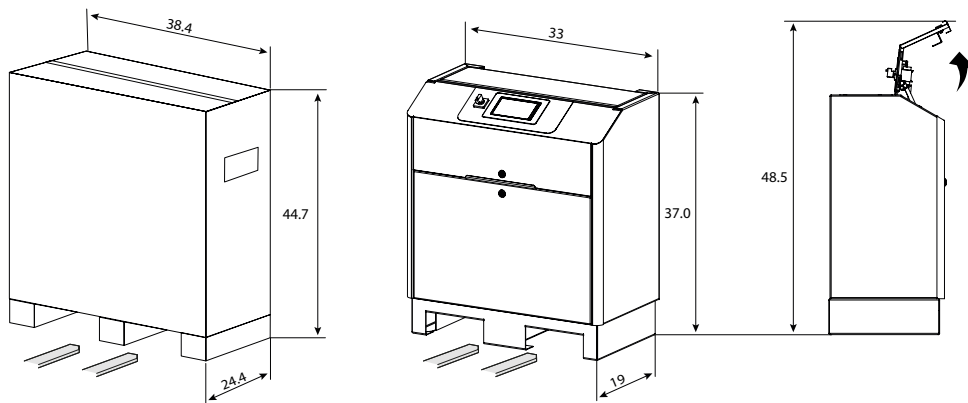

Fig. 4.e

#### 4.3.3 Weight - lb

humiFog multizone Touch models	Weight with/without packaging [lb]
UA150**500/UA150**501/UA150**502	229/ 207
UA300**500/UA300**501/UA300**502	231/ 209
UA500**500/UA500**501/UA500**502	253/ 231
UA800**500/UA800**501/UA800**502	280/ 258
UA1K2**500/UA1K2**501/UA1K2**502	278/ 256

Tab. 4.b

### 4.4 Opening the packaging

- check that the packaging is intact upon delivery and notify the carrier immediately, in writing, of any damage that may be due to improper or negligent transport;
- move the pallet with the pumping station to the installation site before removing it from the packaging, lifting the box using suitable lifting/handling equipment;
- place it near the position where it will be installed;
- remove the packaging.



IMPORTANT: make sure the load does not swing when lifting it.

#### 4.4.4 Material supplied

After opening the packaging and removing the front panel, check that the following are present:

- 1 cable gland (A) for the power supply cable;
- 1 cable gland (B) for the electric cable coming out of the pumping station;
- 1 key (C) for opening the panels,
- NPT fittings (D)
- installation manual

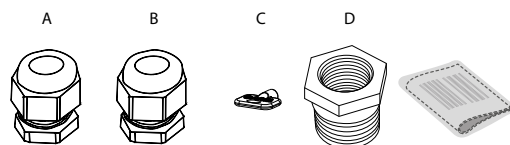

Fig. 4.f



## 4.8 Structure

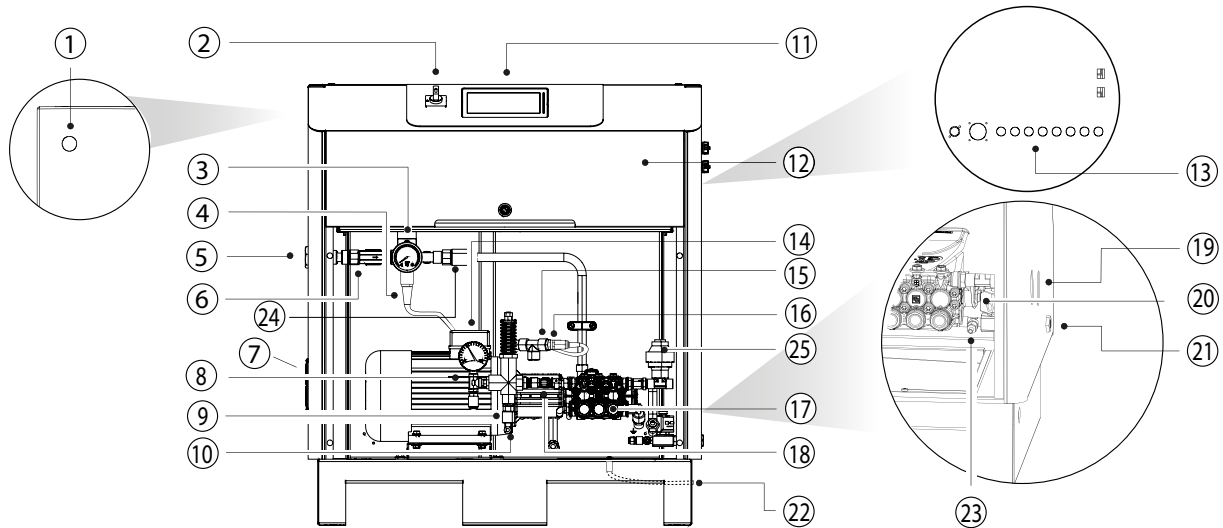

Fig. 4.j

Ref.	Description
1	Opening for the power cable
2	On/Off switch
3	Inlet pressure gauge
4	Low pressure probe
5	Water inlet
6	Supply solenoid valve
7	Cooling fan
8	High pressure switch
9	Temperature probe
10	Thermostat
11	User terminal
12	Electrical panel
13	Openings for cable glands
14	High pressure outlet pressure gauge
15	High pressure control valve
16	High pressure probe
17	Piston pump
18	Elastic joint (internal)
19	Water outlet
20	Cabinet drain solenoid valve
21	Cabinet drain
22	Oil collection tank drain
23	Pressure relief valve
24	Conductivity meter
25	Damper

Tab. 4.c

## 4.9 Accessories

### Zone electrical panel

Electrical panel to be connected to the pumping station for managing multizone in-room or duct systems.



Fig. 4.k

Ref.	Description
UA000SU500	208 V 60 Hz electrical panel
UA000S2500	230 V 60 Hz electrical panel

Tab. 4.d

### 4.9.1 In-room humidification

#### directBOX hydraulic

Water circuit assembly for interfacing the pumping station with the blowers for in-room humidification. It contains the solenoid valves for pressurising 1/2 water lines (zone/step). See technical leaflet +050001828.



Fig. 4.l

Ref.	Description
UAKDLASV10	directBOX hydraulic for managing 1 zone/step
UAKDLASV20	directBOX hydraulic for managing 2 zones/steps

Tab. 4.e

#### directBOX electric

Electrical panel for interfacing the pumping station with the blowers for in-room humidification. It receives the control signal for the fill and drain valve (1 or 2 zones/steps) and relays this to the directBOX hydraulic to actuate the valves. At the same time it controls the blower fans, which are only activated when there is a humidification request. See technical leaflet +050001828.



Fig. 4.m

Ref.	Description
UAKDLAEL10	directBOX electric for managing 1 zone/step
UAKDLAEL20	directBOX electric for managing 2 zones/steps

Tab. 4.f

#### Blower unit

The blowers are positioned directly in the room to be humidified and cooled. They differ in terms of flow rate and direction of spray. They are connected to the pumping station via the directBOX hydraulic and directBOX electric accessories. See technical leaflet +050001852.



Fig. 4.n

Ref.	Description
DLA0****00	Blower with 2 nozzles, 1.45 l/h, 230 V 50 Hz, front delivery

Tab. 4.g



**Notice:**

- X: 2/4/8 = 2/4/8 nozzles
- P: D/U = 230V - 50 Hz/120V - 60 Hz power supply
- T: F/B = delivery from front/front and rear
- Y: 0/1/2 = 1.45/2.80/4.00 l/h.



### Manifolds with nozzles

The distribution system is designed according to the specific application and comprising manifolds, solenoid valves, nozzles, pipes and fittings.

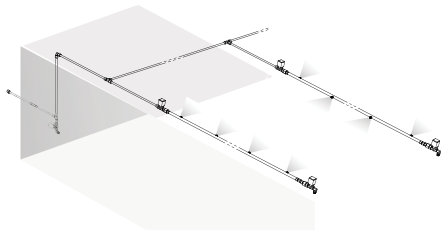

Fig. 4.o

## 4.9.2 Ducted humidification

### Racks

The distribution system is designed according to the specific application and comprising manifolds with nozzles and fixing frame in the duct, available in the fully- or partially-assembled versions.

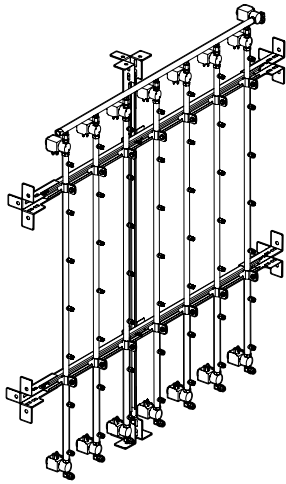

Fig. 4.p

The racks are available with:

- horizontal or vertical collectors;
- solenoid valves fitted on the rack or outside of the air handling unit.

### Droplet separator

Frame with stainless steel or fiberglass modules.



**Notice:** the modules are sized according to the specific application.



Fig. 4.q

# 5. INSTALLATION NOTES

## 5.1 Network connection

See the technical data table for the specifications of the connection cables.

### 5.1.1 Zone panel connection

The connection is made using an Ethernet cable from the pumping station to the zone panels, as shown in the figure.

**IMPORTANT:** the maximum allowed length of an Ethernet connection between two devices is 100 m (for longer distances, use switch P/N KITSE08000).

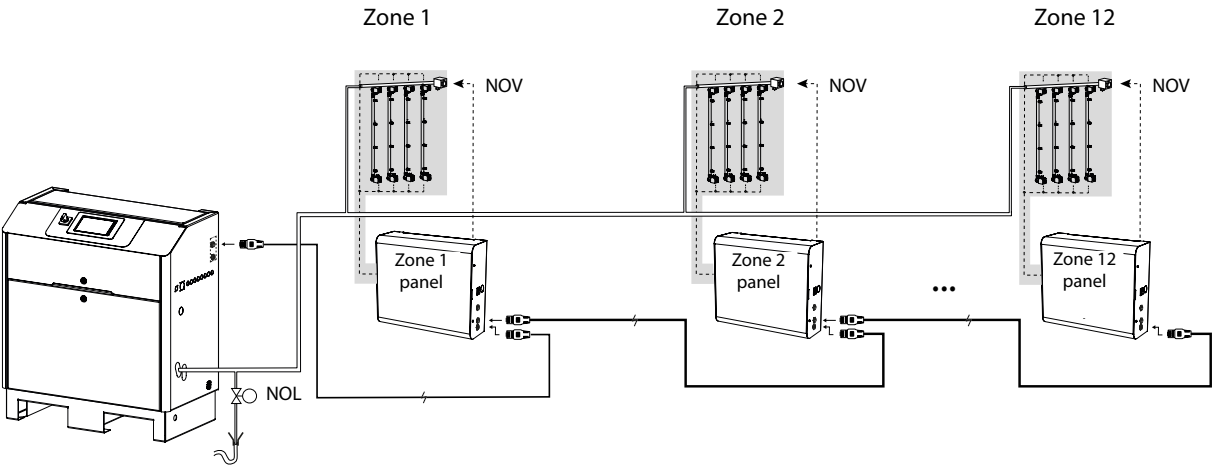

Fig. 5.a

Ref.	Description
NOL	Normally open line drain valve
NOV	Normally open vent valve

Tab. 5.b

### 5.1.2 Supervisor connection

The connection to the supervisor network can be made in two ways:

- between the Ethernet port on the pumping station and the supervisor network
- via RS485 serial link between the BMS2 port on the pumping station controller and the supervisor network. In the latter case, the communication settings need to be changed when commissioning the system.

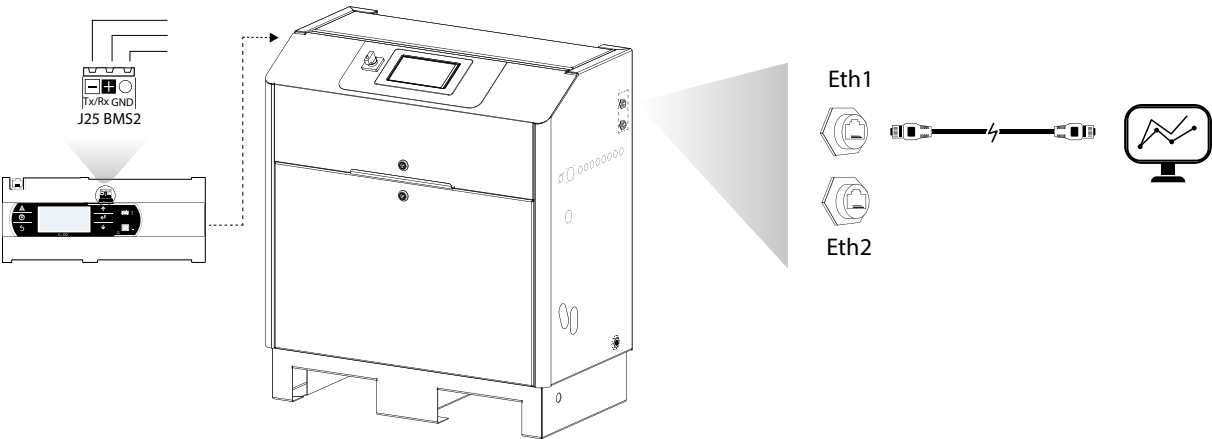

Fig. 5.b

## 5.2 Distribution system

### 5.2.1 Drain valve management (NOL)

The pumping station manages and controls the line drain valve (NOL, normally open). The zone panel can also manage a connected line drain valve.



**Notice:** the line drain valve must be fitted at the lowest point in the water circuit and wired to the nearest electrical panel (pumping station or zone panel), so that when opened, the entire system is emptied.

#### Case 1: Pumping station located below the distribution manifolds

Connect the drain valve near to pumping station that will control its opening.

#### Case 2: Pumping station located above the distribution manifolds, placed at different heights.

The drain valve must be connected near to the lowest distribution manifold.



**Notice:** the control signal for the zone 12 drain valve is output J12 NO3 on the zone electrical panel controller. See the corresponding manual.

#### Case 3: Distribution manifolds located both above and below the pumping station

Connect multiple drain valves at the lowest points in the water circuit.

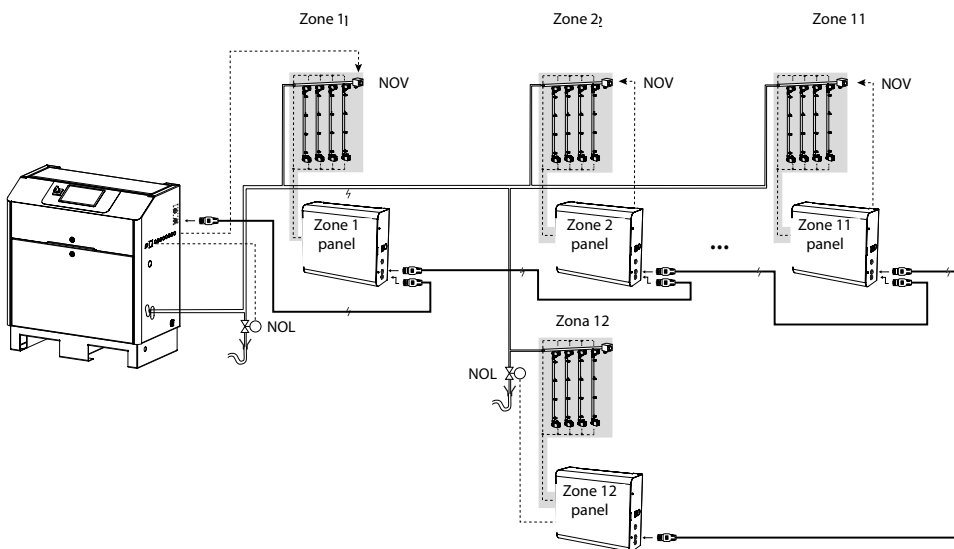

Fig. 5.c

## 5.3 Functional diagrams - room



**IMPORTANT:** the blower fill and drain valves are contained in the directbox hydraulic panel. The maximum allowable length for the water line leaving and re-entering the directbox or that, if no directbox is installed, connects the fill valve to the drain valve, is 1181 inches.



**Notice:** when making the water connections, always observe the following warnings:

- limit as much as possible the length of the fill/drain line on each distribution circuit;
- ensure a minimum slope of the piping to assist emptying during the drain cycle.

### Case 1: 1 zone with 1 steps

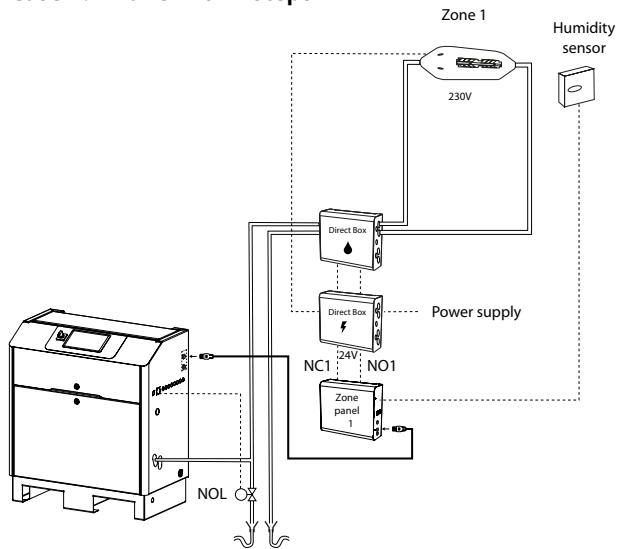

Fig. 5.d

### Case 2: 1 zone with 2 steps

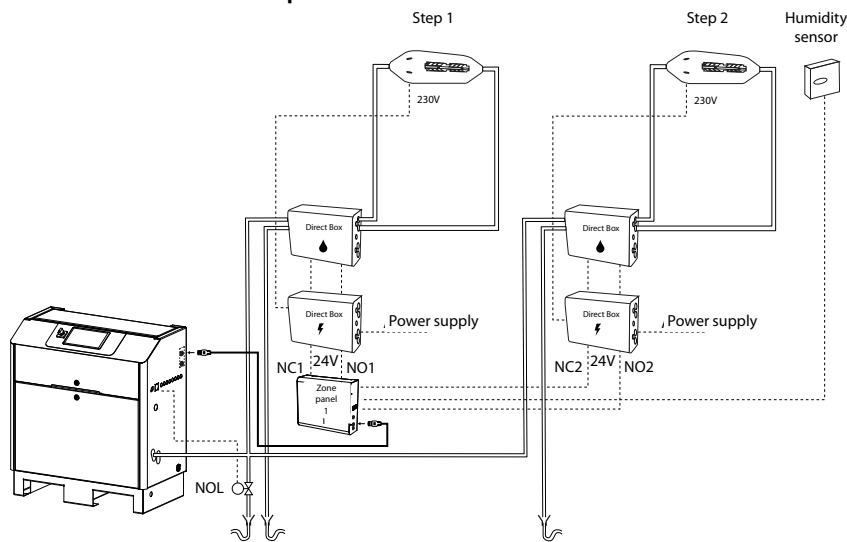

Fig. 5.e

### Case 3: 2 zones with 1 step

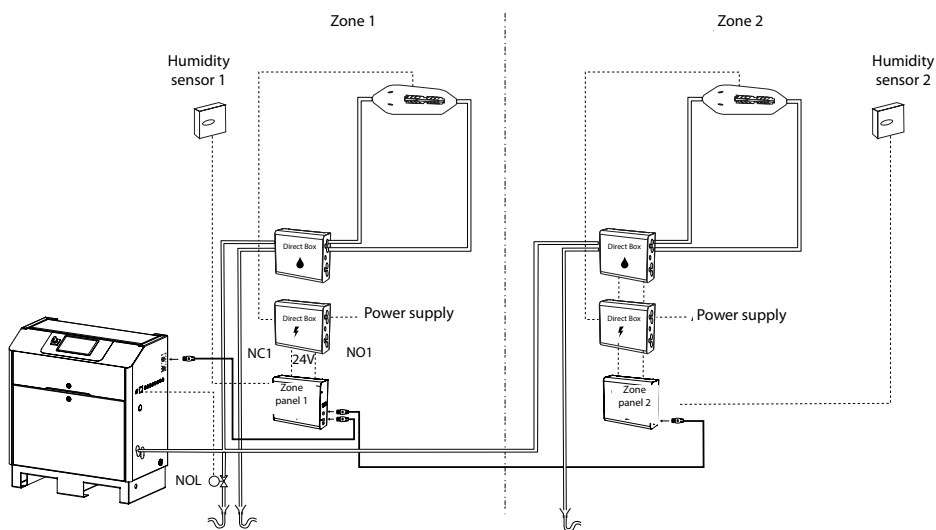

Fig. 5.f

## 5.4 Backup and rotation

### 5.4.1 Backup and rotation connection

The backup and rotation system configuration uses two pumping stations, one primary and the other backup, as well as a zone panel for each zone.

1. Connect the primary pumping station to the backup pumping station via an RJ45 Ethernet cable between the Ethernet port on the two units.
2. Connect one of the two pumping stations to the zone electrical panel as described in the paragraph on *Zone panel connections*.
3. Connect the solenoid valves in the zone distribution system to the corresponding zone electrical panel.

When connecting the NOL valves, there are two distinct possibilities:

- connect the two NOL valves in series, each of which to a different pumping station (as per the following diagram) if the lowest point is near the pumping stations or the NOL valve needs to be connected near to the pumping stations,
- connect a single NOL valve to the nearest zone electrical panel if there is no need to install the NOL valve near the pumping stations.



**Notice:** always install a non-return valve on the outlet line. A non-return valve is required on the outlet line of each individual pumping station, before the two pump water lines join.

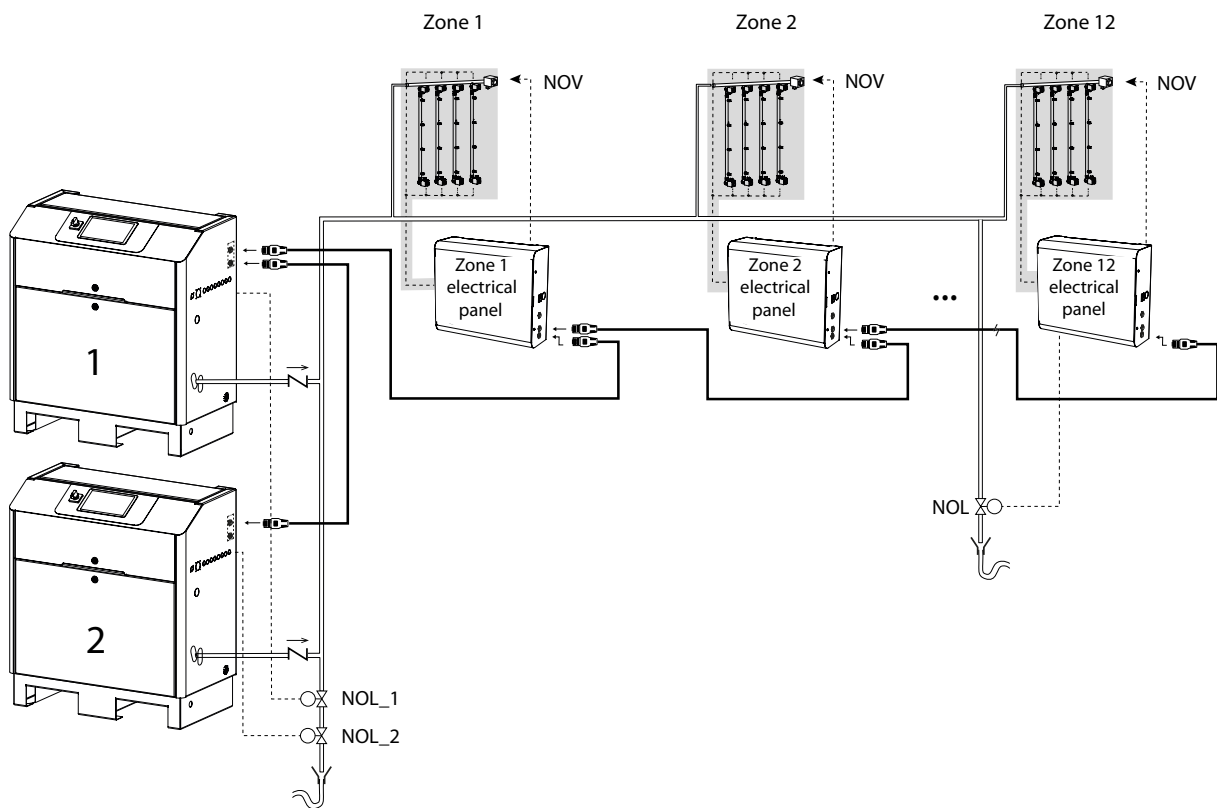

Fig. 5.g

# 6. INSTALLATION

## 6.1 Water connections

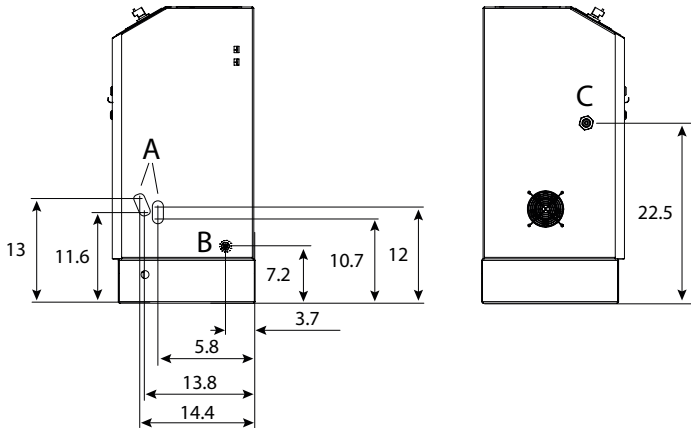

Fig. 6.a

Model	Water inlet (C)	Water outlet (A)	Drain (B)
150	3/4"G - F	M16 x 1.5 - M	1/4"G - F
300	3/4"G - F	M16 x 1.5 - M	1/4"G - F
500	3/4"G - F	M16 x 1.5 - M	1/4"G - F
800	3/4"G - F	M22 x 1.5 - M	1/4"G - F
1200	3/4"G - F	M22 x 1.5 - M	1/4"G - F

Tab. 6.p

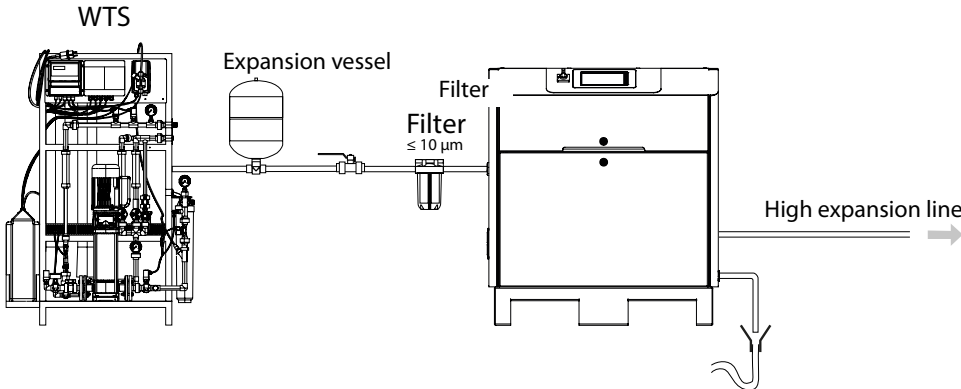

Fig. 6.b

Ref.	Description
WTS	Water Treatment System
Filter	Filter
Expansion vessel	Expansion vessel
High pressure line	High pressure line

Tab. 6.q

1. Install a 10 μm mechanical filter on the feedwater line to trap any solid impurities;
2. Install a shut-off valve upstream of the pumping station to shut off the supply line and carry out maintenance;
3. Install an expansion vessel upstream of the pumping station to dampen the variations in pressure that may occur on the water supply line;
4. Connect the power line to the pumping station;



**Notice:** the internal diameter of the feedwater pipe must be no less than:

0.4 in	UA150-300
0.6 in	UA 500-800-1K2

5. Connect the water drain. Use piping suitable for demineralised water. The drain pipe must be below the pumping station drain to ensure the natural downflow of water;
6. Prepare a funnel to interrupt continuity of the drain pipe and a drain trap to prevent odours for returning;



**Notice:** the funnel and the drain trap must be installed at a height that guarantees the natural downflow of water.

7. Connect the high pressure line to the pumping station.

## 6.2 Feedwater

humiFog must only be supplied with demineralised water.

The use of demineralised water guarantees:

- minimum maintenance;
- no clogging of the nozzles;
- no dust (the droplets that evaporate do not release mineral salts into the AHU/room);
- greater hygiene.

The feedwater must be treated so as to ensure the limit values listed in the table. Under normal circumstances, this means that the water must derive from a reverse osmosis system.

Feedwater specifications	unit of measure	limits	
		min.	max.
(pH) (**)		6.5	8.5
Specific conductivity at 68 °F (**) (σR, 68 °F) for steel pump	μS/cm	0	50
Specific conductivity at 68 °F (**) (σR, 68 °F) for brass pump	μS/cm	30	50
Total hardness (**) (TH)	ppm CaCO3	0	25
Temporary hardness	ppm CaCO3	0	15
Total quantity of dissolved solids (cR)	ppm	(*)	(*)
Dry residue at 356° (R356°F)	ppm	(*)	(*)
Iron + Manganese	ppm Fe+Mn	0	0
Chlorides	ppm Cl	0	10
Silicon dioxide	ppm SiO2	0	1
Residual chlorine	ppm Cl-	0	0
Calcium sulphate	ppm CaSO4	0	5

Tab. 6.r

(1) values dependent on the specific conductivity; in general:

CR  $\cong$  0.65 \* σR, 68 °F; R180  $\cong$  0.93 \* σR, 68 °F

(\*\*) most important values to be taken into consideration for each type of installation.



**IMPORTANT:**

- if the specific conductivity is less than 30 μS/cm, the stainless steel pump is recommended;
- for conductivities higher than 1000 μS/cm, the water must be pre-treated prior to reverse osmosis.

## 6.3 Electrical connections

Before making the connections, make sure that the unit is disconnected from the power supply: turn the main system switch and pumping station switch to OFF.

Install the cable glands on the left and right side of the electrical panel for the electrical cables to pass through.

### 6.3.1 Electrical panel

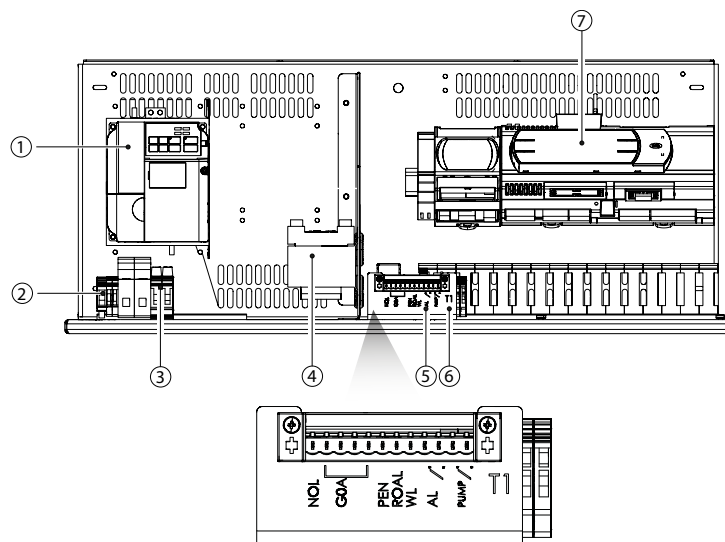

Fig. 6.c

Ref.	Description
1	Inverter
2	Power terminal
3	Fuses F1 to F8 (F8 for three-phase model only)
4	Transformer A (see wiring diagram)
5	Connector T1
6	Fuse F10
7	Electronic controller

Tab. 6.s

### 6.3.2 Power supply



**Notice:** recommended cable size: 0.004 in<sup>2</sup> (AWG 13).

Check that the unit's power supply voltage corresponds to the rated data.  
The connection must be made in compliance with national and local regulations in force.



**IMPORTANT**

- cables must comply with local regulations;
- install a switch upstream of the pumping station to isolate it from the power supply line;
- provide a TT earth system, with earth fault current protection => 30 mA.

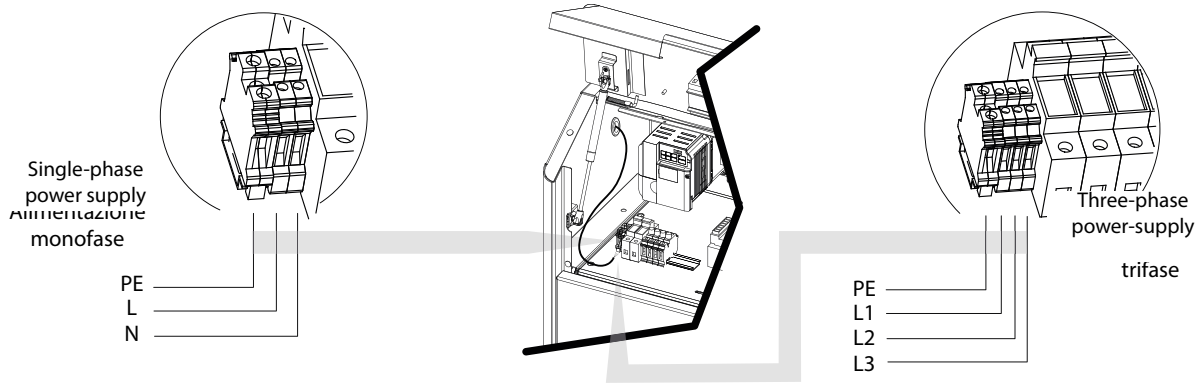

Fig. 6.d

### 6.4 Control connections

The type of control is selected on the user interface. See the humidification system **commissioning manual**.



**Notice:** for all control connections:

- cable sizes: 0.0005 to 0.0008 in<sup>2</sup> (AWG 22/20) up to 1181 inches
- recommended cable size: 0.00124 to 0.002 in<sup>2</sup> (AWG 18/16) > 1181 inches

#### 6.4.1 Enable pumping station production (PEN): Pump Enable



**Notice:** the pumping station is supplied with the PEN-GOA contacts jumpered. To enable the pumping station remotely, remove the jumper and connect a voltage-free contact.

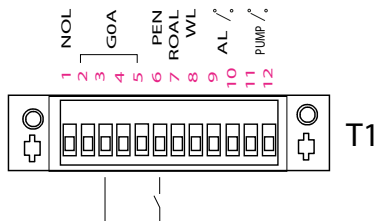

Fig. 6.e

Connector	Terminals
T1	PEN-GOA

Tab. 6.t



## 6.5 Solenoid valve connections

Cable type	Max length
0.00124 in <sup>2</sup> (AWG 18)	1181 in

Tab. 6.u

### 6.5.1 Line drain solenoid valve connection

The line drain valve (NOL) empties the water line that connects the pumping station to the distribution system in each zone.



**IMPORTANT:** this should be installed near the pumping station and in any case at the lowest point in the system, to facilitate emptying by gravity.

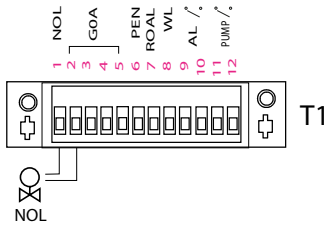

Fig. 6.f

Connector	Terminals
T1	NOL - GOA

Tab. 6.d



**Notice:** recommended cable size: for lengths < 1181 inches: 0.00124 in<sup>2</sup> (AWG 18).

## 6.6 Inputs and outputs

### 6.6.1 Water treatment system (WTS) alarm input

Alarm input from the reverse osmosis water treatment system (WTS).



**Notice:** the pumping station is supplied with the ROAL - GND terminals jumpered.

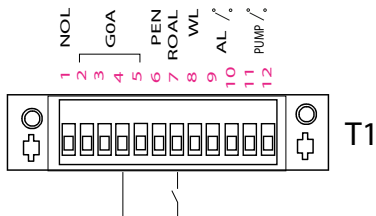

Fig. 6.g

Connector	Terminals	Device
T1	ROAL - GOA	Alarm signal from water treatment system (contact open/closed = alarm present/absent)

Tab. 6.e

### 6.6.2 Water leakage alarm input

Water leakage alarm input, detected by the flood sensor.

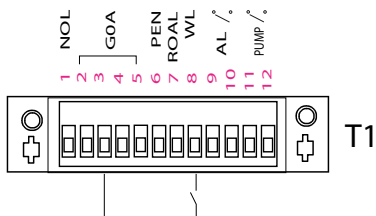

Fig. 6.h

Connector	Terminals	Device
T1	WL - GOA	Flood sensor (contact open/closed = alarm present/absent)

Tab. 6.f

### 6.6.3 Alarm output

The alarm output is activated when one or more alarms are detected. The contact/output can be relayed to a supervisory system.

Relay electrical specifications	Power 500 VA; Voltage 250 V; Current 2 A resistive/inductive	
Relay status and operation	Contact open	alarms present
	Contact closed	no alarms present

Tab. 6.v

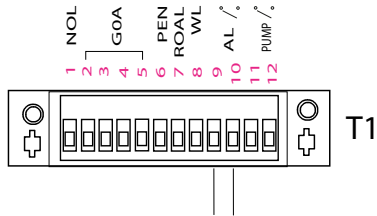

Fig. 6.i

Connector	Terminals
T1	AL

Tab. 6.w

### 6.6.4 Pump status output

Programmable digital output for the following functions:

- pump status (default)
- unit working life
- maintenance warning
- no water alarm
- low inlet pressure (LP) warning
- low inlet pressure (LP) alarm
- frozen water alarm

With the exception of the unit working life function, the relay logic can also be selected between NO (default) and NC.

Relay electrical specifications	Power 500 VA; Voltage 250 V; Current 2 A resistive/inductive		
Relay status and operation	Pump status	Contact open	Pump stopped
		Contact closed	Pump running
	Unit working life	Contact open	Unit off
		Contact closed	Unit on
	Maintenance warning	Contact open	No warnings
		Contact closed	Warnings present
	No water alarm	Contact open	No warnings
		Contact closed	Warnings present
	Low inlet pressure (LP) warning	Contact open	No warnings
		Contact closed	Warnings present
	Low inlet pressure (LP) alarm	Contact open	No alarm
		Contact closed	Alarms present
	Frozen water alarm	Contact open	No alarm
		Contact closed	Alarms present

Tab. 6.x

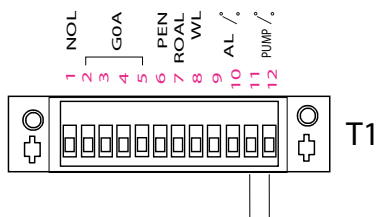

Fig. 6.j

Connector	Terminals
T1	PUMP

Tab. 6.y

## 7. MAINTENANCE

### 7.1 Routine maintenance



**IMPORTANT:** before carrying out any maintenance operations, disconnect the power supply by moving the main system switch and the main switch on the appliance to "off".



**IMPORTANT:** maintenance on the product must be performed by an authorised company that, once the work has been completed, issues the owner a declaration of conformity that the work has been carried out in compliance with the national and local standards in force and the instructions provided by CAREL in the manual supplied with the appliance.



**IMPORTANT:** maintenance must be carried out on the pumping station at least once a year.



**IMPORTANT:** routine maintenance on the pumping station and the humidification system should be performed at the recommended intervals specified in this paragraph. These maintenance operations must only be carried out by qualified personnel.

Routine maintenance is recommended every 3 months, and mainly involves a visual inspection to check that the main components are working correctly. Below is a list of suggested operations:

- **Check the conditions of the inlet water filter.**

The filter cartridge should be replaced once a year. To change the cartridge, switch the unit off and shut-off the feedwater supply line. Empty the filter through the small valve at the bottom. Unscrew the housing from the top ring nut using the tool supplied. Remove the filter cartridge from inside the housing and insert a new one (P/N ACKF100000SP). Screw the housing back on, making sure that the O-ring is still in good condition, to ensure tightness. Close the valve at the bottom of the filter housing and turn the water supply back on.

- **Check the pump oil level.**

Use the dipstick on the yellow pump cap to visually check the oil level. The oil level is correct when measured in the curved portion of the dipstick. If the level is lower than the minimum level shown in the figure, top up with oil to restore the correct level (oil part number UAKOIL0000SP). Generally, the oil level should remain constant and there should be no need to top it up periodically.

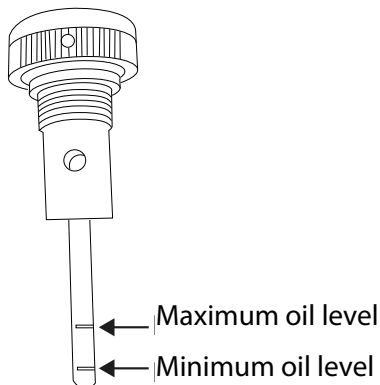

Fig. 7.a

- **Check** that there are no water leaks both inside the cabinet and on the distribution line and on the fittings.

### 7.2 One-off service and repairs

One-off service and repairs are performed in the event of malfunctions or breakages of certain components.

The components that are susceptible to breakage are listed below:

- solenoid valves
- pressure reducer
- pressure switches
- pump motor
- pump
- electronic controller
- fuses
- nozzles
- nozzle manifold
- blower fan

To replace these components, to contact authorised specialist personnel.

To identify the spare part code, see chapter 10 Annexes.

## 7.3 Pump maintenance

The pump is the most complex mechanical device inside the pumping station, as well as the heart of the high pressure system. It therefore requires specific regular maintenance, comprising the activities described below.

Check/replace	Pump	
	monthly	every 1000 h (*)
check oil level	X	
check/change oil		X
check/replace gaskets and valves		X

Tab. 7.a

### 7.3.1 Oil change



**IMPORTANT:** change the oil in the pump (P/N UAKOIL0000SP) after the first 50 operating hours. Failure to change the oil after the first 50 hours can cause damage to the pump and shorten its working life. In fact, the oil supplied with the pump tends to accumulate debris due to transport and initial operation, and cannot guarantee a longer working life.



**IMPORTANT:** if no leaks or malfunctions are found during the "1000 h" check, replacement may be postponed.

(\*) In normal operating conditions, except for the first oil change after 50 hours, the oil needs to be changed every 3000 operating hours. Every 1000 hours, a notification is generated by the electronic controller, while the 3000 operating hours are signalled by the electronic controller via the "3000 hour maintenance" alarm on the display. To change the oil, see the specific maintenance and spare parts manual.

### 7.3.2 Replace gaskets and valves

The gaskets and valves must be replaced every 3000 hours, as signalled by the "3000 hour maintenance" alarm on the display. However, under particularly stressful conditions, replacement may be required before the specified interval. It is recommended to check pump operating status every 1000 hours (as notified by the controller). If the pump generates high noise, or is unable to reach the required working pressure (70 bars), or if water leaks are detected between the pump body and the pump head, it may be necessary to replace the gaskets and valves after a shorter period of time. Valves and gaskets are consumable parts, and their wear is not a result of product malfunctions. To replace the gaskets and valves, see the specific maintenance and spare parts manual.

### 7.3.3 50 hour oil change warning

The first "oil change required" warning for maintenance is signalled after 50 hours of operation: this indicates that an oil change is required. The warning typically appears a few days after starting the system. Therefore, when first operating the appliance, make sure a bottle of oil is available for the first oil change, and that the procedure for changing the oil is clearly understood. The warning can be easily reset by pressing the "alarm" button on the user interface. For practical reasons, the warning can also be reset after 40 hours of operation (but not any earlier).

After changing the oil, the unit's hour counter needs to be reset.

### 7.3.4 Maintenance warning, reset hour counter

After 1000 hours of operation, humiFog generates a "1000 hour maintenance" notification. This alerts the user to check that the system is working properly. If the pump is able to reach the rated operating pressure (70 bars), no action is required.

The notification can be easily reset by pressing the "alarm" button on the user interface. The same occurs after 2000 hours of operation. After 3000 hours of operation, on the other hand, humiFog generates a "3000 hour maintenance" alarm. In this case, work needs to be performed on the unit, changing the oil and replacing the pump gaskets and valves (as described in the previous paragraphs). Then reset the alarm and reset the unit hour counter.

If for some reason the gaskets and valves need to be replaced before 3000 hours of operation, the hour counter also needs to be reset. Whenever the gaskets and valves are replaced, it is also recommended to change the oil before resetting the hour counter.

## 8. TECHNICAL DATA

### 8.1 Technical specifications

	UA1501*50*	UA3001*50*	UA5001*50*	UA8001M50*	UA1K21M50*
<b>ENVIRONMENTAL CONDITIONS</b>					
Operating temperature (°F)	41 to 104°F				
Operating humidity (rH)	0 to 90% non-condensing				
Storage temperature (°F)	-14 to 122°F				
Storage humidity (rH)	0 to 90% non-condensing				
Ingress protection	IP20				
<b>WATER CIRCUIT DATA</b>					
Maximum flow-rate (lb/h)	331 lb/h	661 lb/h	1.102 lb/h	1.763 lb/h	2.645 lb/h
Water conductivity (µS/cm)	<50 µS/cm				
Feedwater pressure (psi)	29-72.5 psi				
Water temperature (°F)	41 to 68°F				
Power supply	G3/4"F				
Outlet	M16x1.5 male			M22x1.5 male	
Main drain	G1/4"F				
Oil collection tank drain	Ø0.5"				
<b>PHYSICAL SPECIFICATIONS</b>					
Weight (lb)	207	209	231	258	256
Dimensions w x d x h	33 x 19 x 37				
Height (inches)	37				
Height with panel open (inches)	49				
Width (inches)	33				
Depth (inches)	19				
Clearance at top (inches)	20				
Clearance at sides (inches)	20				
Clearance at front (inches)	39				
<b>ELECTRICAL SPECIFICATIONS</b>					
Power supply voltage (Vac)	230-208 V (UA***1250* - UA***1U50*)			460 V	
Phases	1			3	
Frequency (Hz)	50/60 Hz (±1%)				
Power (kW)	0.65 kW	1.25kW	1.65 kW	3.35 kW	4.35 kW
FLA current (A)	11 A	14.1 A	14.1 A	8.2 A	8.2 A
Cable size at terminal (in <sup>2</sup> )	0.004 in <sup>2</sup>				
SCCR (kA)	5 kA				
Connections	NPT with adapter				
<b>CONTROLLER SPECIFICATIONS</b>					
Type	c.pCO				
Probe inputs	0 to 1 Vdc, 0 to 10 Vdc, 2 to 10 Vdc, 0 to 20 mA, 4 to 20 mA, NTC				
Serial communication	three-wire RS485 / Fieldbus / BMS				
Communication protocol	Modbus / BACNET				
USB port	1 type A USB port				
Ethernet port	2 Ethernet ports				

Tab. 8.a

### 8.2 Terminal tightening torque

Ref.	Tightening torque (Nm)
Single terminal	5.3 min to 7 max
Double terminal	5.3 min to 7 max
Terminal with fuse	13 min to 16 max
Earth terminal	13 min to 16 max

Tab. 8.b

### 8.3 Fuse chart

Fuse	Pumping station				
	UA1501*5**	UA3001*5**	UA5001*5**	UA8001M5**	UA1K21M5**
F1	1A T 5x20 250 V	1A T 5x20 250 V	1A T 5x20 250 V	1A T 10.3x38 500 V	1A T 10.3x38 500 V
F2	1A T 5x20 250 V	1A T 5x20 250 V	1A T 5x20 250 V	1A T 10.3x38 500 V	1A T 10.3x38 500 V
F5	4A T 5x20 250 V	4A T 5x20 250 V	4A T 5x20 250 V	4A T 5x20 250 V	4A T 5x20 250 V
F6	12A T 10.3x38 500 V	20A F 10.3x38 500 V	25A F 10.3x38 500 V	25A F 10.3x38 500 V	25A F 10.3x38 500 V
F7	12A T 10.3x38 500 V	20A F 10.3x38 500 V	25A F 10.3x38 500 V	25A F 10.3x38 500 V	25A F 10.3x38 500 V
F8	-	-	-	25A F 10.3x38 500 V	25A F 10.3x38 500 V
F10	6.3A T 5x20 250 V	6.3A T 5x20 250 V	6.3A T 5x20 250 V	6.3A T 5x20 250 V	6.3A T 5x20 250 V

Tab. 8.c

# 9. CHECKLIST

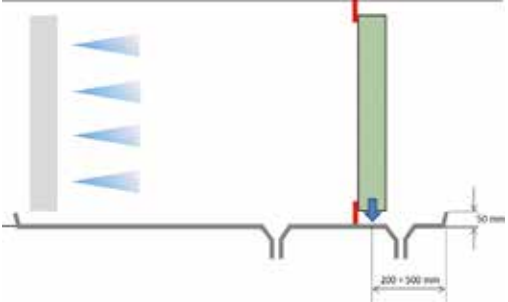
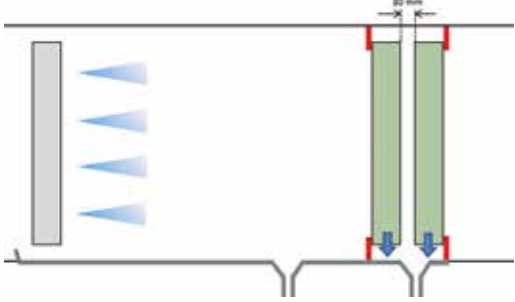
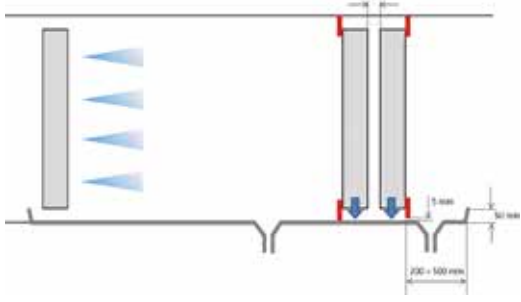
Final installation checklist			
<b>1. Installation site</b>		<b>Yes</b>	<b>No</b>
1.a	Temperature range 34 - 104 °F.		
1.b	Protected against rain and humidity.		
1.c	Protected against direct sunlight.		
<b>2. Water line</b>		<b>Yes</b>	<b>No</b>
2.a	All water connections fitted correctly.		
2.b	Materials compatible for use with water treated by reverse osmosis (stainless steel/plastic).		
2.c	Piping on pumping station feedwater line suitable for an operating pressure range of 2 to 5 bars.		
2.d	Piping of water outlet line from pumping station to the atomisation system suitable for pressures of up to 100 bars.		
2.e	Length of the outlet line from the pumping station to the atomisation system within the limits specified by the manufacturer (par. 5.2).		
2.f	NOL drain solenoid valves installed at the lowest points of the circuit to facilitate drainage of water (Fig. 5.c).		
2.g	Drain pipe and drain tank installed in accordance with the manufacturer's instructions (par. 4.2).		
<b>3. Electrical connections</b>		<b>Yes</b>	<b>No</b>
3.a	Solenoid valves wired in accordance with the manufacturer's instructions (par. 6.2).		
3.b	Connection cables suitably sized for the maximum distance between the pumping station or the zone controller and the rack (par. 6.3).		
3.c	Enabling and control signals wired in accordance with the manufacturer's instructions (par. 6.4).		
3d	Ethernet connection in accordance with the manufacturer's instructions.		
<b>4. Droplet separator</b>		<b>Yes</b>	<b>No</b>
4.a	Double droplet separator at a distance of 3.15"		
4.b	Size of the drain tank underneath the separator from 7.87" to 19.70"		
4.c	Separator installed in accordance with the manufacturer's instructions provided in the quick guide +0500066IE, depending on the type: - single layer  - double layer  - double layer 		

# 10. ANNEXES

## Annex A: Wiring diagrams

Single-phase power supply: UA150\* - UA300\* - UA500\*

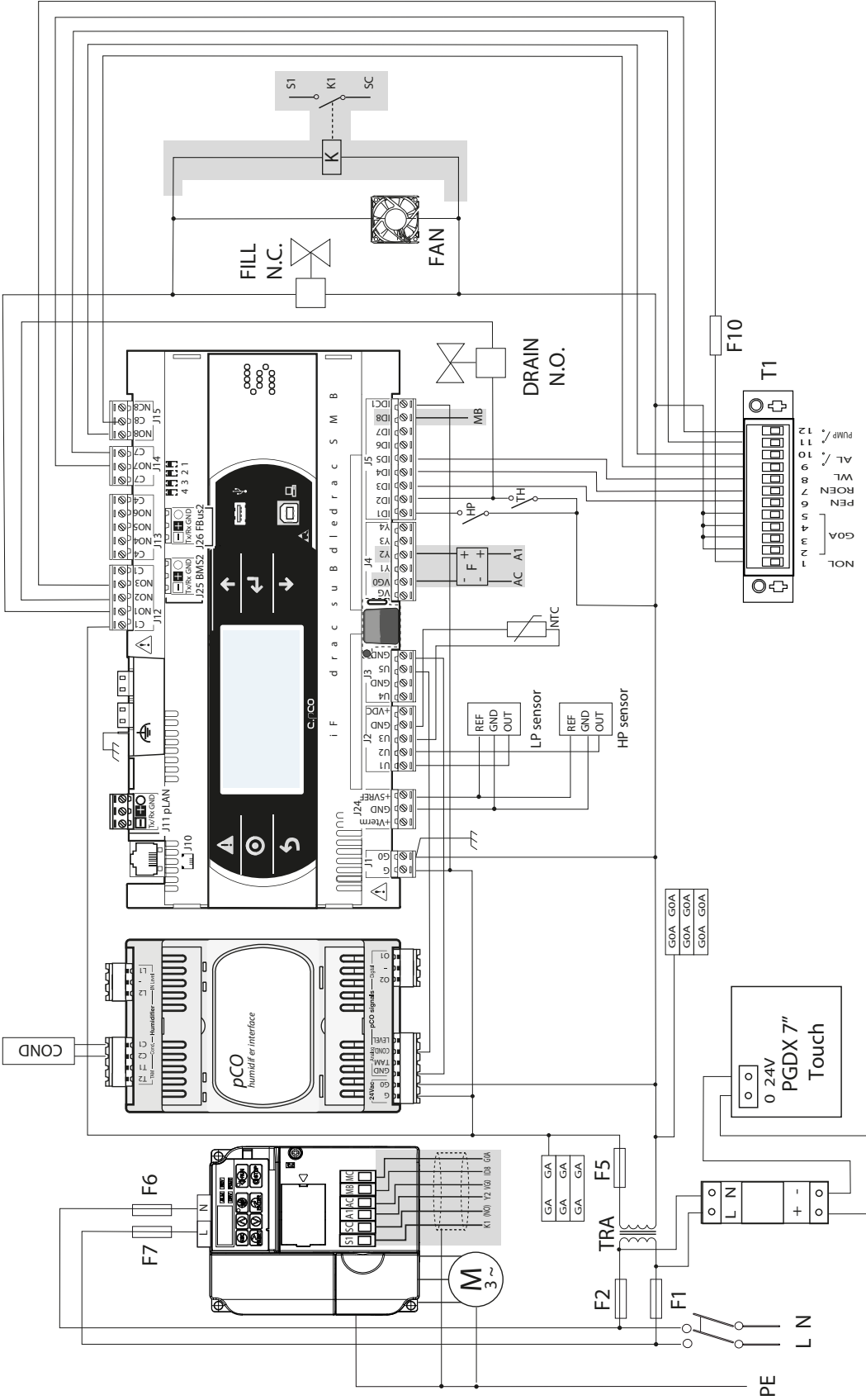

Fig. 10.a

Three-phase power supply: UA800\* - UA1K2\*

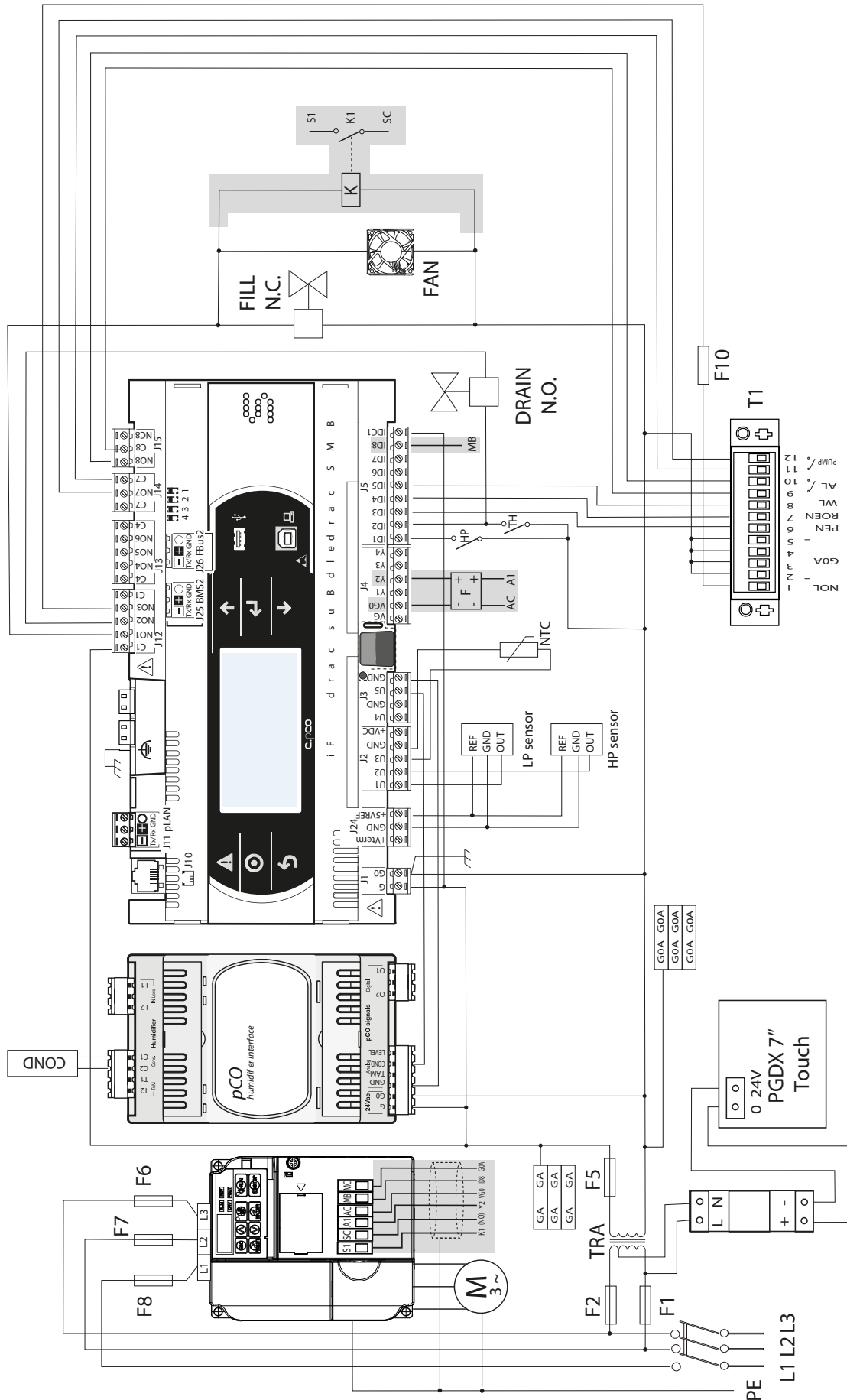

Fig. 10.b



# Annex B: Accessories and spare parts kits

## 1 Mechanical/electrical parts

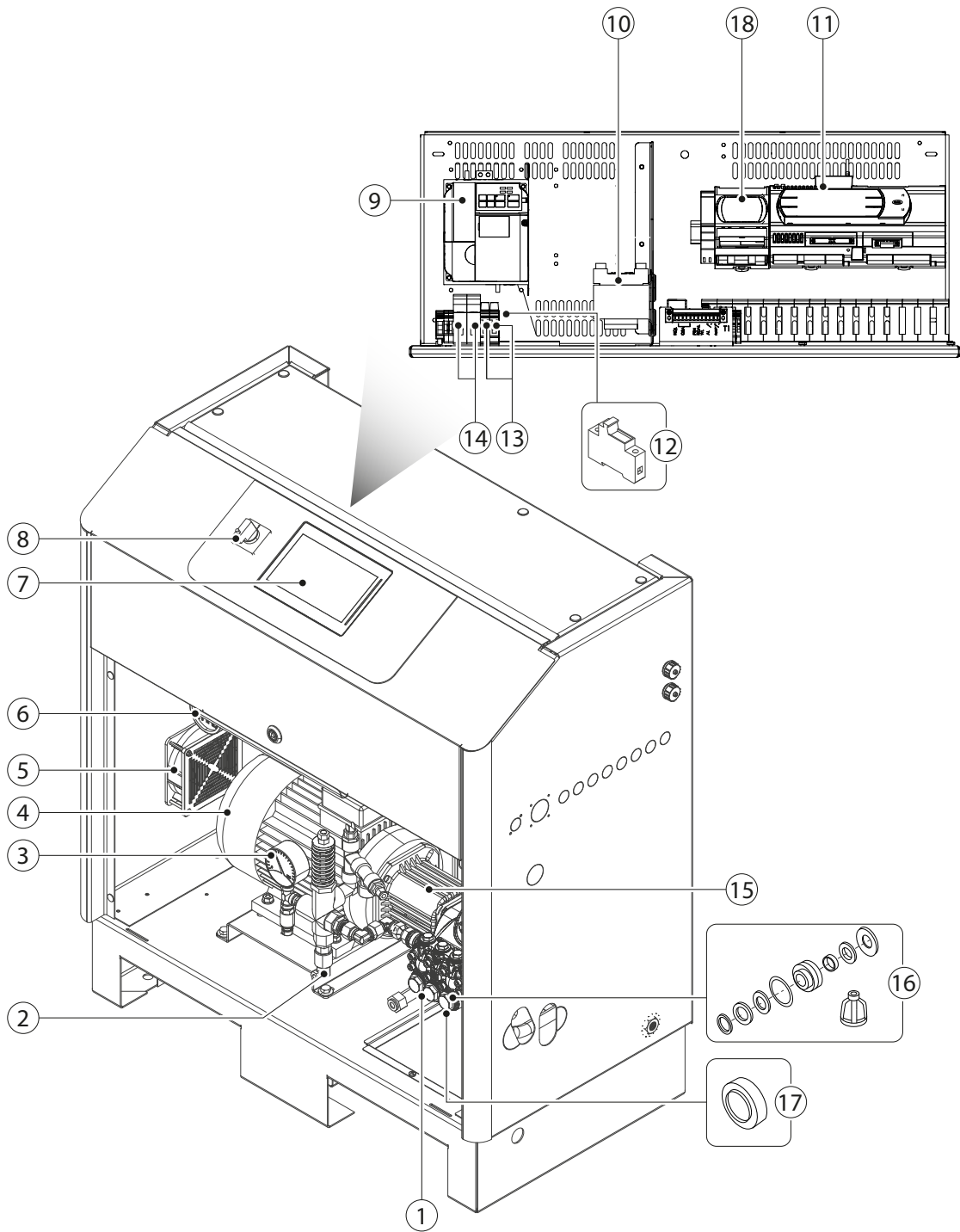

Fig. 10.c

Part number	Description	Ref. figure	Qty per humidifier
UAKP150T00SP	Brass pump for UA150	1	
UAKP300T00SP	Brass pump for UA300	1	
UAKP500T00SP	Brass pump for UA500	1	
UAKP800T00SP	Brass pump for UA800	1	
UAKP1K2T00SP	Brass pump for UA1K2	1	
UAKP150T01SP	Stainless steel pump for UA150	1	
UAKP300T01SP	Stainless steel pump for UA300	1	
UAKP500T01SP	Stainless steel pump for UA500	1	
UAKP800T01SP	Stainless steel pump for UA800	1	
UAKP1K2T01SP	Stainless steel pump for UA1K2	1	
UAKCV0HP00	Pressure control bypass valve, brass	2	
UAKCV0HP01	Pressure control bypass valve, stainless steel	2	
UAKMWH001	Pressure gauge, 0 to 100 bars	3	
UAKM075T60SP	Electric motor for UA150*2-UA150*U, 50-60 Hz UL	4	
UAKM150T60SP	Electric motor for UA300*2-UA300*U, 50-60 Hz UL	4	
UAKM220T60SP	Electric motor for UA500*2-UA500*U, 50-60 Hz UL	4	
UAKM300T60SP	Electric motor for UA800*MU, 50-60 Hz UL	4	
UAKM400T60SP	Electric motor for UA1K2*M, 50-60 Hz UL	4	
URKFANL200	Unit cooling fan	5	
ECKMA10000	Pressure gauge, 0 to 10 bars	6	
UAKPGDX700SP	Touch display for UA*5 pumping station	7	
UAKINT0000	Main switch	8	
UAKVFD0155SP	Variable frequency driver UA150**5	9	
UAKVFD0305SP	Variable frequency driver UA300**5	9	
UAKVFD0505SP	Variable frequency driver UA500**5	9	
UAKVFD0805SP	Variable frequency driver UA800**5	9	
UAKVFD1K25SP	Variable frequency driver UA1K2**5	9	
URKTR10000	100 VA 230/400V 24V transformer	10	
UAKCPCOT00SP	Touchscreen electronic controller for UA*5* pumping station	11	
URKFH10000	2-pole fuse holder	12	
URKFH20000	3-pole fuse holder	12	
UAKFTR0AC1SP	Transformer fuse kit for UA150-300-500 UL	13	
UAKFTR0DE1SP	Transformer fuse kit for UA800-1K2 UL	13	
UAKFVFDA01SP	Inverter fuse kit for UA150 UL	14	
UAKFVFDBE1SP	Inverter fuse kit for UA300-500-800-1K2 UL	14	
UAK0BMC150SP	Pump-motor coupling and flange for UA150	15	
UAK0BMC300SP	Pump-motor coupling and flange for UA300	15	
UAK0BMC500SP	Pump-motor coupling and flange for UA500	15	
UAK0BMC800SP	Pump-motor coupling and flange for UA800	15	
UAK0BMC1K2SP	Pump-motor coupling and flange for UA1K2	15	
UAKVGO1502SP	Gasket and valve kit for UA150-300-500 with brass pump	16	
UAKVGO1802SP	Gasket and valve kit for UA800 with brass pump	16	
UAKVGO2202SP	Gasket and valve kit for UA1K2 with brass pump	16	
UAKVGX1502SP	Gasket and valve kit for UA150-300-800 with stainless steel pump	16	
UAKVGX1802SP	Gasket and valve kit for UA800 with stainless steel pump	16	
UAKVGX2202SP	Gasket and valve kit for UA1K2 with stainless steel pump	16	
UAKAR00001SP	Oil seal kit for UA150-300-500-800-1K2*5*0 brass, UA1K2*5*1 stainless steel	17	
UAKAR00002SP	Oil seal kit for UA150-300-500-800 stainless steel	17	
PCOUMI2000	Electronic expansion alongside the touchscreen controller	18	
UAKVG000EX	Extractor rod for UA****5 gaskets and valves		
UAKVG015EX	Seal and valve extractor for UA150-300-500		
UAKVG022EX	Seal and valve extractor for UA800		
UAKVG018EX	Seal and valve extractor for UA1K2		
UAKVGX15IN	Gasket and valve inserter for UA150-300-500 with stainless steel pump		
UAKVGX18IN	Gasket and valve inserter for UA800 with stainless steel pump		
UAKVGO15IN	Gasket and valve inserter for UA150-300-500 with brass pump		
UAKVGO18IN	Gasket and valve inserter for UA800 with brass pump		
UAKVG022IN	Gasket and valve inserter for UA1K2 with stainless steel and brass pump		
UAKART0001	UA150-300-500-800 brass oil seal extractor and inserter		
UAKART0002	UA1K2 stainless steel and brass oil seal extractor and inserter		
UAKART0003	UA150-300-500-800 stainless steel oil seal extractor and inserter		

Tab. 10.a

**2 Water circuit parts**

Fig. 10.d

Part number	Description	Ref. figure	Quantity per humidifier
UAKTS00000SP	High temperature thermostat	19	
UAKPSHP000	High pressure switch (HP)	20	
ECKFSV0000	Water fill solenoid valve for UA*4, UA*D, EC*, UA1505*, UA3005*, UA5005*	21	
MCKFSVAC00	Water fill solenoid valve for UA8005*, UA1K25*, brass	21	
UGKEVOUT00SP	Water fill solenoid valve for UA8005*, UA1K25*, stainless steel	21	
UAKCV0DR00	Cabinet drain solenoid valve, brass	22	
UAKCV0DR01	Cabinet drain solenoid valve, stainless steel	22	
UAKSAFVAL0	Safety valve	23	
UAKRACLP01SP	PVC low pressure fittings kit	24	
UAKTRAS05V	0-5 V high pressure probe	25	
SPKT0013P0	Low pressure probe	26	
SPKT0011S0	Low pressure probe	26	
HSCONDUT00	Conductivity meter	27	
UAKSMZ0000SP	Pulsation damper	28	
UAKOIL0000SP	Oil for humiFog pump	-	





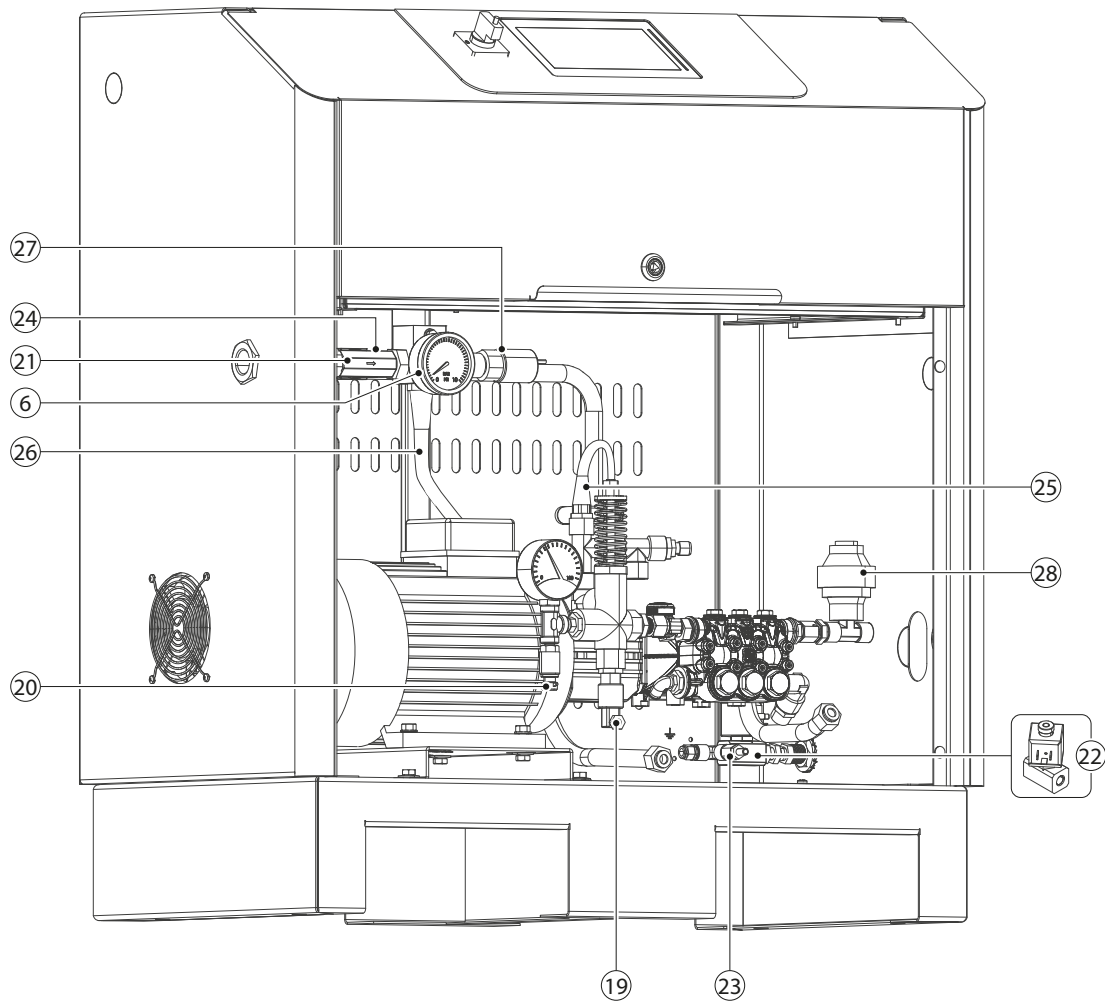



# CAREL

---

CAREL INDUSTRIES - Headquarters  
Via dell'Industria, 11 - 35020 Brugine - Padova (Italy)  
Tel. (+39) 049.9716611 - Fax (+39) 049.9716600  
e-mail: [carel@carel.com](mailto:carel@carel.com) - [www.carel.com](http://www.carel.com)

humiFog Touch +0300113EN rel. 1.0 - 15.03.20221