



# Gree VRF communication protocol V2.0

MC30-24/D1 (BM)

ME30-24/D1 (BM)

**GREE ELECTRIC APPLIANCES, INC. OF ZHUHAI**

**Thanks for choosing Gree central air conditioner VRF Protocol Gateway. To ensure proper use of the Gateway in the building management system, please read this communication protocol carefully before operation and keep it for future reference.**

## Content

Chapter 1: BACnet Protocol .....	3
1 Structure of BACnet Protocol .....	4
2 Object and Property of BACnet Protocol .....	4
2.1 Definition of BACnet Object .....	4
2.2 Table of BACnet Protocol Point .....	4
3 VRF Parameters List .....	5
3.1 VRF Object_List Parameters List .....	20
Chapter 2: Modbus Protocol .....	22
1 Terms and Definitions .....	23
2 Brief Introduction of BMS .....	24
3 Modbus Protocol Format .....	24
3.1 General .....	24
3.2 Protocol Interface .....	24
3.3 Hardware Interface .....	24
3.3.1 Modbus RTU Mode .....	24
3.3.2 Modbus TCP Mode .....	25
3.4 Modbus communication frame format .....	25
3.4.1 Universal Communication Frame Format of Modbus under RTU Mode .....	25
3.4.2 Modbus TCP mode general communication frame format .....	25
3.5 Modbus Standard Protocol Format .....	25
3.5.1 Coil (Bit) .....	25
3.5.2 Register (Word, 16 Bit) .....	26
3.5.3 Modbus RTU mode example .....	27
3.5.4 Modbus TCP mode example .....	30
4 Communication Protocol for CAN Series Unit .....	35
4.1 General .....	35
4.2 Precautions before the Development of BMS Interface .....	35
4.3 Definitions of Effective Data .....	38
4.3.1 ODU and IDU of Multi VRF Units .....	39
Error parameter .....	47
4.3.2 Energy recovery ventilation system .....	57
5. Precautions before the Use of Gateway .....	68
Annex A .....	69
A.1 CRC Calculation Method .....	69
A.2 How to Calculate CRC .....	69
A.3 CRC Example (For Reference Only) .....	70
References .....	70

# Chapter 1: BACnet Protocol

## 1 Structure of BACnet Protocol

The structure of BACnet standard protocol is specific to building self-control system characteristics, a simplified 4-layer structure from OSI 7-layer structure; this 4-layer is corresponding to the application layer, network layer, data link and physical layer in OSI model. BACnet standard protocol defines its application layer and network layer, and provides the following 5 solutions to its data link and physical layers.

BACnet Layers				Equivalent OSI Layers
BACnet Application Layer				Application
BACnet Network Layer				Network
ISO8802-2 (IEEE802.2) Type1	MS/TP	PTP	LonTalk	Data Link
ISO8802-3 (IEEE802.3)	ARCNET	EIA-485 (RS485)		EIA-232 (RS232)

## 2 Object and Property of BACnet Protocol

### 2.1 Definition of BACnet Object

BACnet defines a group of objects with property to represent any functions of building self-control equipment, thus provide a standard method to represent building self-control equipment. The Gateway defines 9 objects, the enumeration number, name and application sample of these objects are introduced as follows.

No.	Object name	Application sample
0	Analog Input	Sensor input
1	Analog Output	Control output
2	Analog Value	The set valve value or other analog control system parameter
3	Binary Input	Switch input
4	Binary Output	Relay output
5	Binary Value	Digital control system parameter
13	Multi-state Input	Indicate a multi-state processing program situation, such as open/close refrigerator and defrosting cycle etc.
14	Multi-state Output	Indicate a multi-state processing program expectation status, e.g. started cooling time for refrigerator.
19	Multi-state Value	Indicate a multi-state processing program parameter, such as AC fan speed setting and mode setting, etc.

Each object has a set of property, the property value describes the features and functions of the objects.

### 2.2 Table of BACnet Protocol Point

One BACnet object ID is consist of the following 5 parts:

BACnet object ID (32bits)				
10 bits	3 bits	2 bits	9 bits	8 bits
Reserved	Model series (assigned to be 0)(M)	Equipment type(01,02,03)(D)	Equipment migration(N)	Parameter No.(P)

**Equipment type:** include the gateway itself (0), IDU (1), ODU (2) and IO module (3).

**Equipment migration:** for IDU object, it means the IDU No.;

**Parameter number:** the sequence of parameter number after data conversion;

**ID value of BACnet object:**

BACnet ID = P+N\*256+D\*256\*512+M\*256\*512\*4;

For example indoor ambient temperature of object (IndoorUnitAmbientTemp\_01\_01\_01) , its BACnet object

ID is (IndoorUnitAmbientTemp\_01\_01\_01) with the following meaning:

BACnet object ID(32bits)

10 bits	3 bits	2 bits	9 bits	8 bits
Reserved	Model series (assigned to be 0)(M)	Equipment type(01,02,03)(D)	Equipment migration(N)	Parameter No.(P)
0	0:Multi VRF	1:IDU	1	1

If the value of initial IDU engineering code object (FirstIndoorUnitNum\_01\_00\_00 with object ID of 1) of this Gateway is M, then IndoorUnitAmbientTemp\_01\_01\_01 (131329) represents a IDU parameter with the engineering code of (M+1).

### 3 VRF Parameters List

ODU and IDU of Multi VRF Units:

Equipment	Object type	Parameter name	Instance No.	Current value
IDU	Indoor ambient temperature	AI	(N-1)*256+131072	Actual value(°C):-30~138
	Rated capacity of IDU	AI	(N-1)*256+131073	Actual value(KW): 2.2;2.5;2.8;3.2;3.6;4.0;4.5;5.0;5.6;6.3;7.1; 8.0;9.0;10.0;11.2;12.5;14.0;16.0;18.0; 22.4;25.0;28.0;33.5;35.0;40.0;45.0;50.0; 56.0
	Indoor relative humidity	AI	(N-1)*256+131104	Actual value(%):20~90
	Hardware version	AI	(N-1)*256+131105	Actual value=Transmission value/100
	Software version	AI	(N-1)*256+131106	Actual value=Transmission value/100
	Communication protocol version	AI	(N-1)*256+131107	Actual value=Transmission value/100
	Temperature setting	AV	(N-1)*256+131072	Actual value(°C):16.0~30.0
	Lower limit temperature setting for cooling energy saving	AV	(N-1)*256+131073	Actual value(°C):16.0~30.0
	Upper limit temperature setting for heating energy saving	AV	(N-1)*256+131074	Actual value(°C):16.0~30.0
	Lower limit temperature setting for dehumidifying energy saving	AV	(N-1)*256+131075	Actual value(°C):16.0~30.0
	Humidity setting	AV	(N-1)*256+131090	Actual value(%):0~100
	With IDU or not	BI	(N-1)*256+131072	0:No , 1:Yes
	Other malfunctions	BI	(N-1)*256+131073	0:No , 1:Yes
	Communication error between gateway and IDU	BI	(N-1)*256+131074	0:No , 1:Yes
	IDU general error	BI	(N-1)*256+131075	0:No , 1:Yes
	IDU protection	BI	(N-1)*256+131076	0:No , 1:Yes
	Indoor fan protection	BI	(N-1)*256+131077	0:No , 1:Yes
	Full water protection	BI	(N-1)*256+131078	0:No , 1:Yes
	Power supply overload protection	BI	(N-1)*256+131079	0:No , 1:Yes
	Anti freezing protection	BI	(N-1)*256+131080	0:No , 1:Yes
Mode conflict	BI	(N-1)*256+131081	0:No , 1:Yes	

Malfunction of indoor circuit board	BI	(N-1)*256+131082	0:No , 1:Yes
IDU temperature sensor malfunction	BI	(N-1)*256+131083	0:No , 1:Yes
Ambient temperature sensor malfunction	BI	(N-1)*256+131084	0:No , 1:Yes
Inlet temperature sensor malfunction	BI	(N-1)*256+131085	0:No , 1:Yes
Outlet temperature sensor malfunction	BI	(N-1)*256+131086	0:No , 1:Yes
Humidity sensor malfunction	BI	(N-1)*256+131087	0:No , 1:Yes
Communication malfunction	BI	(N-1)*256+131088	0:No , 1:Yes
Engineering number conflict of IDU	BI	(N-1)*256+131089	0:No , 1:Yes
Missing main IDU	BI	(N-1)*256+131090	0:No , 1:Yes
One controller for multiple units, and the number of IDU is inconsistent (HBS network)	BI	(N-1)*256+131091	0:No , 1:Yes
Main mode of IDU/subordinate mode of IDU	BI	(N-1)*256+131092	0:Slave IDU 1:Master IDU
Auxiliary electrical heating of IDU	BI	(N-1)*256+131093	0:Off , 1:On
ON/OFF	BV	(N-1)*256+131072	0:Off , 1:On
Energy saving setting	BV	(N-1)*256+131073	0:Off , 1:On
Remote shield energy saving function	BV	(N-1)*256+131074	0:No shield , 1:Shield
Remote shield temperature setting function	BV	(N-1)*256+131075	0:No shield , 1:Shield
Remote shield mode function	BV	(N-1)*256+131076	0:No shield , 1:Shield
Remote shield on/off function	BV	(N-1)*256+131077	0:No shield , 1:Shield
Remote lock function	BV	(N-1)*256+131078	0:No lock 1:Lock
IDU memory	BV	(N-1)*256+131079	0:Standby 1:Power-failure memory
Give priority to IDU when supplying power	BV	(N-1)*256+131080	0:No , 1:Yes
8 degrees Celsius heating function setting	BV	(N-1)*256+131081	0:Cancel 8 degrees Celsius heating 1:Start 8 degrees Celsius heating
Dry	BV	(N-1)*256+131082	0:Off , 1:On
Ventilation	BV	(N-1)*256+131083	0:Off , 1:On
Shield ON	BV	(N-1)*256+131084	0:No shield , 1:Shield
Shield OFF	BV	(N-1)*256+131085	0:No shield , 1:Shield
Shield timer	BV	(N-1)*256+131086	0:No shield , 1:Shield
Forbid opening auxiliary heating	BV	(N-1)*256+131087	0:Cancel low-temperature dehumidification 1:Start low-temperature dehumidification
Dehumidifying under low temperature	BV	(N-1)*256+131088	0: Auxiliary heating is allowable 1: Auxiliary heating is not allowable
Cancel filter cleaning remind	BV	(N-1)*256+131089	0:No , 1:Yes
Rapid Cooling/heating	BV	(N-1)*256+131100	0: Invalid 1: Rapid Cooling/heating

	All IDUs open	BO	(N-1)*256+131072	0:Invalid , 1:All on
	All IDUs closed	BO	(N-1)*256+131073	0:All off , 1:Invalid
	The subordinated ODU No. of IDU	MI	(N-1)*256+131072	Actual value:1~16
	Gate control status	MI	(N-1)*256+131073	Actual value: 1:Invalid 2:Without door control 3:Card is inserted 4:Card is disconnected
	Operation mode setting	MV	(N-1)*256+131072	Actual value: 1:Invalid 2:Cooling 3:Dehumidifying 4:Fan 5:Heating 6:Auto 7:Floor heating 8:Rapid heating 9:Heat supply
IDU	Fan speed setting	MV	(N-1)*256+131073	Actual value: 1:Invalid 2:Auto fan speed 3:Low 4: Medium-low 5:Medium 6:Medium-high 7:High 8:Turbo 9:Fan stop
	Vertical swing	MV	(N-1)*256+131074	Actual value: 1:Invalid 2:Off 3:15 swing 4:1 position 5:2 position 6:3 position 7:4 position 8:5 position 9:35 swing 10:25 swing 11:24 swing 12:14 swing 13:13 swing
	Horizontal swing	MV	(N-1)*256+131075	Actual value: 1:Invalid 2:Off 3:Homodromous 4:swing 5:1 position 6:2 position 7:3 position 8:4 position 9:5 position 10:35 swing 11:25 swing 12:24 swing 13:14 swing 14:13 swing 15:15 position 16:Opponent swing
	Quiet	MV	(N-1)*256+131076	Actual value: 1:Invalid data 2:Quiet off 3:Auto quiet 4:Quiet

	Sleep	MV	(N-1)*256+131077	Actual value: 1:Invalid data 2:Sleep off 3:Sleep 1 4:Sleep 2 5:Sleep 3
	Static pressure value(Motor model for AC)	MV	(N-1)*256+131087	Actual value: 1:Invalid 2:static pressure 1 3:static pressure 2 4:static pressure 3 5:static pressure 4 6:static pressure 5 7:static pressure 6 8:static pressure 7 9:static pressure 8 10:static pressure 9
	Static pressure value(Motor model for DC)	MV	(N-1)*256+131088	Actual value: 1:Invalid 2:static pressure 1 3:static pressure 2 4:static pressure 3 5:static pressure 4 6:static pressure 5 7:static pressure 6 8:static pressure 7 9:static pressure 8 10:static pressure 9 11:static pressure 10 12:static pressure 11 13:static pressure 12 14:static pressure 13
ODU	Outdoor ambient temperature	AI	(N-1)*256+262144	Actual value(°C):-30~155
	Module 1 effective value of power grid side phase voltage	AI	(N-1)*256+262145	Actual value(V):0~510
	Module 1 PV DC bus voltage	AI	(N-1)*256+262146	Actual value(V):0~65535
	Module 1 power grid side current	AI	(N-1)*256+262147	Actual value(A):0~255.99
	Module 1 power grid side grid connection power	AI	(N-1)*256+262148	Actual value(KW):-327.680~327.670
	Module 1 PV power	AI	(N-1)*256+262149	Actual value(KW):0~655.350
	Module 1 quantity of side grid connection	AI	(N-1)*256+262150	Actual value(KWH):-9.102~9.102
	Module 1 quantity of PV power generation	AI	(N-1)*256+262151	Actual value(KWH):0~18.204
	Module 1 PV side input current	AI	(N-1)*256+262152	Actual value(A):0~255.99
	Module 1 Power of PV DC input side 1 power generation	AI	(N-1)*256+262153	Actual value(KW):0~655.350
	Module 1 Power of PV DC input side 2 power generation	AI	(N-1)*256+262154	Actual value(KW):0~655.350
	Module 1 Power generation of PV DC input side 1	AI	(N-1)*256+262155	Actual value(KWH):0~18.204
	Module 1 Power generation of PV DC input side 2	AI	(N-1)*256+262156	Actual value(KWH):0~18.204
	Module 2 effective value of power grid side phase voltage	AI	(N-1)*256+262157	Actual value(V):0~510
Module 2 PV DC bus voltage	AI	(N-1)*256+262158	Actual value(V):0~65535	



Module 2 power grid side current	AI	(N-1)*256+262159	Actual value(A):0~255.99
Module 2 power grid side grid connection power	AI	(N-1)*256+262160	Actual value(KW):-327.680~327.670
Module 2 PV power	AI	(N-1)*256+262161	Actual value(KW):0~655.350
Module 2 quantity of side grid connection	AI	(N-1)*256+262162	Actual value(KWH):-9.102~9.102
Module 2 quantity of PV power generation	AI	(N-1)*256+262163	Actual value(KWH):0~18.204
Module 2 PV side input current	AI	(N-1)*256+262164	Actual value(A):0~255.99
Module 2 Power of PV DC input side 1 power generation	AI	(N-1)*256+262165	Actual value(KW):0~655.350
Module 2 Power of PV DC input side 2 power generation	AI	(N-1)*256+262166	Actual value(KW):0~655.350
Module 2 Power generation of PV DC input side 1	AI	(N-1)*256+262167	Actual value(KWH):0~18.204
Module 2 Power generation of PV DC input side 2	AI	(N-1)*256+262168	Actual value(KWH):0~18.204
Module 3 effective value of power grid side phase voltage	AI	(N-1)*256+262169	Actual value(V):0~510
Module 3 PV DC bus voltage	AI	(N-1)*256+262170	Actual value(V):0~65535
Module 3 power grid side current	AI	(N-1)*256+262171	Actual value(A):0~255.99
Module 3 power grid side grid connection power	AI	(N-1)*256+262172	Actual value(KW):-327.680~327.670
Module 3 PV power	AI	(N-1)*256+262173	Actual value(KW):0~655.350
Module 3 quantity of side grid connection	AI	(N-1)*256+262174	Actual value(KWH):-9.102~9.102
Module 3 quantity of PV power generation	AI	(N-1)*256+262175	Actual value(KWH):0~18.204
Module 3 PV side input current	AI	(N-1)*256+262176	Actual value(A):0~255.99
Module 3 Power of PV DC input side 1 power generation	AI	(N-1)*256+262177	Actual value(KW):0~655.350
Module 3 Power of PV DC input side 2 power generation	AI	(N-1)*256+262178	Actual value(KW):0~655.350
Module 3 Power generation of PV DC input side 1	AI	(N-1)*256+262179	Actual value(KWH):0~18.204
Module 3 Power generation of PV DC input side 2	AI	(N-1)*256+262180	Actual value(KWH):0~18.204
Module 4 effective value of power grid side phase voltage	AI	(N-1)*256+262181	Actual value(V):0~510
Module 4 PV DC bus voltage	AI	(N-1)*256+262182	Actual value(V):0~65535
Module 4 power grid side current	AI	(N-1)*256+262183	Actual value(A):0~255.99
Module 4 power grid side grid connection power	AI	(N-1)*256+262184	Actual value(KW):-327.680~327.670
Module 4 PV power	AI	(N-1)*256+262185	Actual value(KW):0~655.350

Module 4 quantity of side grid connection	AI	(N-1)*256+262186	Actual value(KWH):-9.102~9.102
Module 4 quantity of PV power generation	AI	(N-1)*256+262187	Actual value(KWH):0~18.204
Module 4 PV side input current	AI	(N-1)*256+262188	Actual value(A):0~255.99
Module 4 Power of PV DC input side 1 power generation	AI	(N-1)*256+262189	Actual value(KW):0~655.350
Module 4 Power of PV DC input side 2 power generation	AI	(N-1)*256+262190	Actual value(KW):0~655.350
Module 4 Power generation of PV DC input side 1	AI	(N-1)*256+262191	Actual value(KWH):0~18.204
Module 4 Power generation of PV DC input side 2	AI	(N-1)*256+262192	Actual value(KWH):0~18.204
Grid-connected power	AI	(N-1)*256+262193	Actual value(KWH):0~3.403*10^38
MPPT1 power generation	AI	(N-1)*256+262194	Actual value(KWH):0~3.403*10^38
Power of MPPT1 power generation	AI	(N-1)*256+262195	Actual value(KW):0~65.5350
MPPT2 power generation	AI	(N-1)*256+262196	Actual value(KWH):0~3.403*10^38
Power of MPPT2 power generation	AI	(N-1)*256+262197	Actual value(KW):0~65.5350
Power number of indoor	AI	(N-1)*256+262198	Actual value:0~255
Module 1 percentage setting for PV side limit power	AV	(N-1)*256+262144	Actual value(%):0~100
Module 2 percentage setting for PV side limit power	AV	(N-1)*256+262145	Actual value(%):0~100
Module 3 percentage setting for PV side limit power	AV	(N-1)*256+262146	Actual value(%):0~100
Module 4 percentage setting for PV side limit power	AV	(N-1)*256+262147	Actual value(%):0~100
Upper limit setting of ODU capacity	AV	(N-1)*256+262148	Actual value(%):30~100
Percentage upper limit setting of demand power	AV	(N-1)*256+262149	Actual value(%):0~100
Communication malfunction between gateway and ODU	BI	(N-1)*256+262144	0:No , 1:Yes
With ODU or not	BI	(N-1)*256+262145	0:No , 1:Yes
Other malfunctions	BI	(N-1)*256+262146	0:No , 1:Yes
Back flow protection for 4-way valve	BI	(N-1)*256+262147	0:No , 1:Yes
Pressure ratio is abnormal	BI	(N-1)*256+262148	0:No , 1:Yes
High pressure protection	BI	(N-1)*256+262149	0:No , 1:Yes
Low pressure protection	BI	(N-1)*256+262150	0:No , 1:Yes
High discharge temperature protection	BI	(N-1)*256+262151	0:No , 1:Yes
Overload protection	BI	(N-1)*256+262152	0:No , 1:Yes

ODU	Communication malfunction	BI	(N-1)*256+262153	0:No , 1:Yes
	Outdoor ambient temperature sensor malfunction	BI	(N-1)*256+262154	0:No , 1:Yes
	Discharge sensor fall-off malfunction	BI	(N-1)*256+262155	0:No , 1:Yes
	High pressure sensor malfunction	BI	(N-1)*256+262156	0:No , 1:Yes
	Low pressure sensor malfunction	BI	(N-1)*256+262157	0:No , 1:Yes
	Discharge sensor malfunction	BI	(N-1)*256+262158	0:No , 1:Yes
	Capacity match abnormal	BI	(N-1)*256+262159	0:No , 1:Yes
	Defrosting sensor malfunction	BI	(N-1)*256+262160	0:No , 1:Yes
	Subcooler sensor malfunction	BI	(N-1)*256+262161	0:No , 1:Yes
	Vapour separator sensor malfunction	BI	(N-1)*256+262162	0:No , 1:Yes
	Fan drive board malfunction	BI	(N-1)*256+262163	0:No , 1:Yes
	Compressor drive board malfunction	BI	(N-1)*256+262164	0:No , 1:Yes
	Compressor drive board working abnormal	BI	(N-1)*256+262165	0:No , 1:Yes
	Voltage protection for compressor drive board power	BI	(N-1)*256+262166	0:No , 1:Yes
	Fan drive board working abnormal	BI	(N-1)*256+262167	0:No , 1:Yes
	Voltage protection for fan drive board power	BI	(N-1)*256+262168	0:No , 1:Yes
	Module 1 malfunction	BI	(N-1)*256+262169	0:No , 1:Yes
	Module 2 malfunction	BI	(N-1)*256+262170	0:No , 1:Yes
	Module 3 malfunction	BI	(N-1)*256+262171	0:No , 1:Yes
	Module 4 malfunction	BI	(N-1)*256+262172	0:No , 1:Yes
	High pressure over low protection	BI	(N-1)*256+262173	0:No , 1:Yes
	Unrecoverable malfunction in ODU system	BI	(N-1)*256+262174	0:No , 1:Yes
	Recoverable malfunction in ODU system	BI	(N-1)*256+262175	0:No , 1:Yes
	Discharge temperature over low protection	BI	(N-1)*256+262176	0:No , 1:Yes
	Pressure sensor malfunction	BI	(N-1)*256+262177	0:No , 1:Yes
	General malfunction of ODU	BI	(N-1)*256+262178	0:No , 1:Yes
	Compressor operation status	BI	(N-1)*256+262179	0:Off , 1:On
	Unit debugging status	BI	(N-1)*256+262180	0:Normal 1:Debug
Power supply is insufficient	BI	(N-1)*256+262181	0:No , 1:Yes	
Module 1 side grid connection status ON/OFF of power	BI	(N-1)*256+262182	0:Off , 1:On	

grid			
Module 1 MPPT ON/OFF status	BI	(N-1)*256+262183	0:Off , 1:On
Module 1 percentage setting for PV side limit power	BI	(N-1)*256+262184	0: Normal 1: Limit frequency
Module 1 mark of electric quantity statistics	BI	(N-1)*256+262185	0: Power calculation is not done 1: Power calculation is done
Module 2 side grid connection status ON/OFF of power grid	BI	(N-1)*256+262186	0:Off , 1:On
Module 2 MPPT ON/OFF status	BI	(N-1)*256+262187	0:Off , 1:On
Module 2 percentage setting for PV side limit power	BI	(N-1)*256+262188	0: Normal 1: Limit frequency
Module 2 mark of electric quantity statistics	BI	(N-1)*256+262189	0: Power calculation is not done 1: Power calculation is done
Module 3 side grid connection status ON/OFF of power grid	BI	(N-1)*256+262190	0:Off , 1:On
Module 3 MPPT ON/OFF status	BI	(N-1)*256+262191	0:Off , 1:On
Module 3 percentage setting for PV side limit power	BI	(N-1)*256+262192	0: Normal 1: Limit frequency
Module 3 mark of electric quantity statistics	BI	(N-1)*256+262193	0: Power calculation is not done 1: Power calculation is done
Module 4 side grid connection status ON/OFF of power grid	BI	(N-1)*256+262194	0:Off , 1:On
Module 4 MPPT ON/OFF status	BI	(N-1)*256+262195	0:Off , 1:On
Module 4 percentage setting for PV side limit power	BI	(N-1)*256+262196	0: Normal 1: Limit frequency
Module 4 mark of electric quantity statistics	BI	(N-1)*256+262197	0: Power calculation is not done 1: Power calculation is done
With module 1 or not	BI	(N-1)*256+262198	0:No , 1:Yes
With module 2 or not	BI	(N-1)*256+262199	0:No , 1:Yes
With module 3 or not	BI	(N-1)*256+262200	0:No , 1:Yes
With module 4 or not	BI	(N-1)*256+262201	0:No , 1:Yes
ODU remote control emergency stop	BV	(N-1)*256+262144	0:No , 1:Yes
Remote energy saving mark	BV	(N-1)*256+262145	0:Off , 1:On
Cooling/heating mode of the whole unit	MI	(N-1)*256+262144	Actual value: 1:Invalid 2:Cooling only 3:Heating 4:Cooling and heating 5:Fan

	Emergency operation mode	MI	(N-1)*256+262145	Actual value: 1:Invalid 2:No emergency operation 3:Emergency operation of compressor 4:Emergency operation of fan 5:Emergency operation of module
	MPPT1 operation status	MI	(N-1)*256+262146	Actual value: 1:OFF 2:Standby 3:ON 4:Run
	MPPT2 operation status	MI	(N-1)*256+262147	Actual value: 1:OFF 2:Standby 3:ON 4:Run

## Hot-water and Floor-heating Units:

Equip ment	Object type	Parameter name	Instance No.	Current value
IDU	Current hot water temperature	AI	(N-1)*256+131074	Actual value(°C):-30~100
	Wired controller displays water temperature value of water tank	AI	(N-1)*256+131075	Actual value(°C):-30~100
	High temperature sterilization cycle of water tank	AV	(N-1)*256+131076	Range:0~60
	High temperature sterilization time of water tank(minute)	AV	(N-1)*256+131077	Range:0~59
	High temperature sterilization time of water tank(hour)	AV	(N-1)*256+131078	Range:0~23
	Hot water preset time(minute)	AV	(N-1)*256+131079	Range:0~59
	Hot water preset time(hour)	AV	(N-1)*256+131080	Range:0~23
	Intelligent daytime hot water insulation setting temperature of water tank with external coil or internal coil	AV	(N-1)*256+131081	Actual value(°C):35~50
	High temperature sterilization setting temperature of water tank with external coil or internal coil	AV	(N-1)*256+131082	Actual value(°C):65~70
	Outlet water setting temperature of floor heating	AV	(N-1)*256+131083	Actual value(°C):25~45

Hot water heating/insulation status	BI	(N-1)*256+131094	1:Heating 0:Insulation
Floor heating/insulation status	BI	(N-1)*256+131095	1:Heating 0:Insulation
Icon of high temperature sterilization	BI	(N-1)*256+131096	1:Normal sterilization 0:Without
Cycle pump operation status	BI	(N-1)*256+131097	1:On 0:Off
Startup status of hot water auxiliary electric heater	BI	(N-1)*256+131098	1:On 0:Off
Startup prohibitive icon of hot water auxiliary electric heater	BI	(N-1)*256+131099	1:On 0:Off
Startup status of floor heating auxiliary electric heater	BI	(N-1)*256+131100	1:On 0:Off
If floor heating shunt valve 1 is open	BI	(N-1)*256+131101	1:On 0:Off
If floor heating shunt valve 2 is open	BI	(N-1)*256+131102	1:On 0:Off
If floor heating shunt valve 3 is open	BI	(N-1)*256+131103	1:On 0:Off
If floor heating shunt valve 4 is open	BI	(N-1)*256+131104	1:On 0:Off
If floor heating shunt valve 5 is open	BI	(N-1)*256+131105	1:On 0:Off
If floor heating shunt valve 6 is open	BI	(N-1)*256+131106	1:On 0:Off
Hot water on/off	BV	(N-1)*256+131090	1:On 0:Off
Floor heating on/off	BV	(N-1)*256+131091	1:On 0:Off
Rapid hot water function	BV	(N-1)*256+131092	1:Rapid 0:Normal
Auto setting of hot water temperature	BV	(N-1)*256+131093	1:Auto 0:Without
Sunflower function	BV	(N-1)*256+131094	1:On 0:Off
Water tank and floor heating in priority under the same hydro box	BV	(N-1)*256+131095	1:Floor heating 0:Water tank
Remote lock of hot water function	BV	(N-1)*256+131096	1:Lock 0:Unlock
Rapid floor heating function	BV	(N-1)*256+131097	1:Rapid 0:Normal
Floor heating absence function	BV	(N-1)*256+131098	1:Rapid 0:Normal
High temperature sterilization setting of water tank with external coil or internal coil	BV	(N-1)*256+131099	1:Set 0:Not set
Auto setting of hydro box floor heating water temperature	BV	(N-1)*256+131101	1:Auto 0:Without
Remote lock of hydro box floor heating function	BV	(N-1)*256+131102	1:On 0:Off
Hot water volume of water tank	MI	(N-1)*256+131074	Actual value: 1:Invalid 2:1/5 capacity

				3:2/5 capacity 4:3/5 capacity 5:4/5 capacity 6:5/5 capacity
	Configuration of hydro box	MI	(N-1)*256+131075	Actual value: 1:Invalid 2:Gree water tank 3:Floor heating 4:Gree water tank + floor heating 5:Gree water tank + solar power 6:3 in 1
	Hot water operation mode	MV	(N-1)*256+131078	Actual value: 1:Invalid 2:Standard hot water 3:Preset hot water 4:Hot water at night

## Energy recovery ventilation system:

Equipment	Object type	Parameter name	Instance No.	Current value
IDU	Return air and air inlet temperature	AI	(N-1)*256+131076	Actual value(°C):-30~138
	Fresh air outlet temperature sensor	AI	(N-1)*256+131077	Actual value(°C):-30~138
	Fresh air inlet temperature sensor	AI	(N-1)*256+131078	Actual value(°C):-30~138
	Indoor relative humidity	AI	(N-1)*256+131079	Actual value(%):20~90
	Pollution degree of roughing efficiency filter	AI	(N-1)*256+131080	Actual value(%):0~100
	Pollution degree of high efficiency filter	AI	(N-1)*256+131081	Actual value(%):0~100
	Indoor air box 1: temperature sensor	AI	(N-1)*256+131082	Actual value(°C):-30~138
	Indoor air box 2: temperature sensor	AI	(N-1)*256+131083	Actual value(°C):-30~138
	Indoor air box 3: temperature sensor	AI	(N-1)*256+131084	Actual value(°C):-30~138
	Indoor air box 4: temperature sensor	AI	(N-1)*256+131085	Actual value(°C):-30~138
	Indoor air box 5: temperature sensor	AI	(N-1)*256+131086	Actual value(°C):-30~138
	Indoor air box 1: humidity sensor	AI	(N-1)*256+131087	Actual value(%):20~90
	Indoor air box 2: humidity sensor	AI	(N-1)*256+131088	Actual value(%):20~90
	Indoor air box 3: humidity sensor	AI	(N-1)*256+131089	Actual value(%):20~90
	Indoor air box 4: humidity sensor	AI	(N-1)*256+131090	Actual value(%):20~90
	Indoor air box 5: humidity sensor	AI	(N-1)*256+131091	Actual value(%):20~90
	Outdoor relative humidity	AI	(N-1)*256+131092	Actual value(%):20~90
	Working status of indoor air box	AI	(N-1)*256+131093	Range: 0~00011111 0: Not working 1: Working bit n means air box No.n
	Indoor air box 1: PM2.5 value	AI	(N-1)*256+131094	Range:0~65535
	Indoor air box 2: PM2.5 value	AI	(N-1)*256+131095	Range:0~65535

Indoor air box 3: PM2.5 value	AI	(N-1)*256+131096	Range:0~65535
Indoor air box 4: PM2.5 value	AI	(N-1)*256+131097	Range:0~65535
Indoor air box 5: PM2.5 value	AI	(N-1)*256+131098	Range:0~65535
Indoor air box 1: CO2 value	AI	(N-1)*256+131099	Range:0~65535
Indoor air box 2: CO2 value	AI	(N-1)*256+131100	Range:0~65535
Indoor air box 3: CO2 value	AI	(N-1)*256+131101	Range:0~65535
Indoor air box 4: CO2 value	AI	(N-1)*256+131102	Range:0~65535
Indoor air box 5: CO2 value	AI	(N-1)*256+131103	Range:0~65535
Temperature setting	AV	(N-1)*256+131072	Actual value(°C):16.0~30.0
Indoor air box LED indicator	AV	(N-1)*256+131084	Range: 0~00011111 0: Turn on 1: Turn off bit n means air box No.n
Indoor main air box	AV	(N-1)*256+131085	Range: 0~00011111 0:No main box 1:Set it as the main box bit n means air box No.n
PM2.5 sensor on/off	AV	(N-1)*256+131086	Range: 0~00011111 0: Off 1: On bit n means air box No.n
Indoor relative humidity setting	AV	(N-1)*256+131087	Actual value(%):0~100
Max. outdoor relative humidity setting	AV	(N-1)*256+131088	Actual value(%):0~100
Setting for indoor air box switch	AV	(N-1)*256+131089	Range: 0~00011111 0: Not working 1: Working bit n means air box No.n
IDU error	BI	(N-1)*256+131107	1:Error 0:Normal
Errors of several main wired controllers	BI	(N-1)*256+131108	1:Error 0:Normal
Conflict of IDU project No	BI	(N-1)*256+131109	1:Error 0:Normal
Main communication error of IDU	BI	(N-1)*256+131110	1:Error 0:Normal
Main communication error of IDU and ODU	BI	(N-1)*256+131111	1:Error 0:Normal
(Airflow volume) dial code setting error	BI	(N-1)*256+131112	1:Error 0:Normal
Fresh air outlet temperature sensor error	BI	(N-1)*256+131113	1:Error 0:Normal
Indoor humidity sensor error	BI	(N-1)*256+131114	1:Error 0:Normal
Anti-freezing protection	BI	(N-1)*256+131115	1:Error 0:Normal
Communication error between IDU and indoor box 1	BI	(N-1)*256+131116	1:Error 0:Normal
Communication error between IDU and indoor box 2	BI	(N-1)*256+131117	1:Error 0:Normal
Communication error between IDU and indoor box 3	BI	(N-1)*256+131118	1:Error 0:Normal
Communication error	BI	(N-1)*256+131119	1:Error



between IDU and indoor box 4			0:Normal
Communication error between IDU and indoor box 5	BI	(N-1)*256+131120	1:Error 0:Normal
Indoor fan protection	BI	(N-1)*256+131121	1:Error 0:Normal
Return air and air inlet temperature sensor error	BI	(N-1)*256+131122	1:Error 0:Normal
IFD error	BI	(N-1)*256+131123	1:Error 0:Normal
Return air and air outlet temperature sensor error	BI	(N-1)*256+131124	1:Error 0:Normal
Communication error between IDU and air box	BI	(N-1)*256+131125	1:Error 0:Normal
Electrostatic dedusting	BI	(N-1)*256+131126	1: On 0: Off
Filter dirty cleaning alarm	BI	(N-1)*256+131127	0: No 1: Filter cleaning
Filter dirty replacement alarm	BI	(N-1)*256+131128	0: No 1: Replacement alarm
IFD filter screen cleaning alarm	BI	(N-1)*256+131129	0: No 1: Replacement alarm
High efficiency filter screen replacement alarm	BI	(N-1)*256+131130	0: No 1: Replacement alarm
Fresh air inlet temperature sensor error	BI	(N-1)*256+131131	1: Error 0: Normal
Startup/shutdown setting	BV	(N-1)*256+131103	1: On 0: Off
Turbo fan speed function status	BV	(N-1)*256+131104	1: On 0: Off
Long distance shielding control mode function	BV	(N-1)*256+131105	1: Shield 0: No shield
Long distance shielding ON/OFF function	BV	(N-1)*256+131106	1: Shield 0: No shield
Long distance lock function	BV	(N-1)*256+131107	1: Shield 0: No shield
Shielding ON	BV	(N-1)*256+131108	1: Shield 0: No shield
Shielding OFF	BV	(N-1)*256+131109	1: Shield 0: No shield
Shield timer	BV	(N-1)*256+131110	1: Shield 0: No shield
Auxiliary electrical heater	BV	(N-1)*256+131111	1:Auxiliary heating ON 0:Auxiliary heating OFF
Health	BV	(N-1)*256+131112	1:On , 0:Off
Humidifier	BV	(N-1)*256+131113	1:On , 0:Off
Energy saving mode	BV	(N-1)*256+131114	1:On , 0:Off
Cancel IFD filter cleaning alarm	BV	(N-1)*256+131115	0:No 1:Command the IDU to clear
Cancel high efficiency filter screen replacement alarm	BV	(N-1)*256+131116	0:No 1:Command the IDU to clear
Cancel filter cleaning alarm	BV	(N-1)*256+131117	0:No 1:Command the IDU to clear
Cancel filter replacement alarm	BV	(N-1)*256+131118	0:No 1:Command the IDU to clear
Valid mode of IDU	MI	(N-1)*256+131076	Actual value: 0x00:Invalid

				0x01:Valid operation 0x02:Valid linkage 0x04:Valid automation
	Pollution grade of outdoor air	MI	(N-1)*256+131077	Actual value: 1:Invalid 2:Excellent 3:Good 4:Mild pollution 5:Medium pollution 6:Heavy pollution 7:Severe pollution
	Indoor air box 1: Air quality grade	MI	(N-1)*256+131078	Actual value: 1:Invalid 2:Excellent 3:Good 4:Mild pollution 5:Medium pollution 6:Heavy pollution 7:Severe pollution
	Indoor air box 2: Air quality grade	MI	(N-1)*256+131079	Actual value: 1:Invalid 2:Excellent 3:Good 4:Mild pollution 5:Medium pollution 6:Heavy pollution 7:Severe pollution
	Indoor air box 3: Air quality grade	MI	(N-1)*256+131080	Actual value: 1:Invalid 2:Excellent 3:Good 4:Mild pollution 5:Medium pollution 6:Heavy pollution 7:Severe pollution
	Indoor air box 4: Air quality grade	MI	(N-1)*256+131081	Actual value: 1:Invalid 2:Excellent 3:Good 4:Mild pollution 5:Medium pollution 6:Heavy pollution 7:Severe pollution
	Indoor air box 5: Air quality grade	MI	(N-1)*256+131082	Actual value: 1:Invalid 2:Excellent 3:Good 4:Mild pollution 5:Medium pollution 6:Heavy pollution 7:Severe pollution
	Operation speed of exhaust fan	MI	(N-1)*256+131083	Actual value: 1:Invalid data 2:The fan stops 3:Ultra-low speed 4:Low speed 5:Medium and low speed 6:Medium speed 7:Medium and high speed 8:High speed 9:Ultra-high speed 10:Quiet speed R1 11:Quiet speed R2 12:Quiet speed R3

	Operation mode setting	MV	(N-1)*256+131072	Actual value: 1:Invalid 2:Cooling 3:Dehumidifying 4:Fan 5:Heating 6:Auto 7:Floor heating 8:Rapid heating 9:Heat supply
	Control mode of fresh air unit	MV	(N-1)*256+131079	Actual value: 1:Invalid 2:Operation 3:Linkage 4:Auto
	Operation speed of fresh air unit	MV	(N-1)*256+131080	Setting : 1: invalid 2: auto fan speed 3: low fan speed 4: Medium low fan speed 5: Medium fan speed 6: Medium high fan speed 7: High fan speed Read : 1: Invalid data 2: The fan stops 3: Ultra-low speed 4: Low speed 5: Medium and low speed 6: Medium speed 7: Medium and high speed 8: High speed 9: Ultra-high speed 10: Quiet speed R1 11: Quiet speed R2 12: Quiet speed R3
	Operation mode of fresh air unit	MV	(N-1)*256+131081	Setting : 1: Invalid data 2: Total heat exchange mode 3: Bypass mode 4: Exhaust fan mode 5: Low temperature mode  Read : 1: Invalid data 2: Total heat mode 3: Bypass mode 4: Exhaust fan mode 5: Low temperature mode 6: Inner circulation 1 7: Inner circulation 2
	Positive and negative pressure setting	MV	(N-1)*256+131082	Actual value: 1:Invalid data 2:Normal fan speed 3:Positive pressure mode 4:Negative pressure mode
	Positive pressure speed setting	MV	(N-1)*256+131083	Actual value: 1:Invalid 2:Speed 0 3:Speed 1 4:Speed 2 5:Speed 3 6:Speed 4 7:Speed 5

	Fresh air uni static pressure	MV	(N-1)*256+131084	Actual value: 1:Invalid 2:0Pa 3:25Pa 4:50Pa 5:75Pa 6:100Pa
	Target value of indoor air quality grade	MV	(N-1)*256+131085	Actual value: 1:Invalid 2:Excellent 3:Good
	Outdoor air pollution grade	MV	(N-1)*256+131086	Actual value: 1:Invalid 2:Excellent 3:Good 4:Mild pollution 5:Medium pollution 6:Severe pollution 7:Serious pollution

### 3.1 VRF Object\_List Parameters List

Equipment	Object type	Parameter name	Instance No.	Current value
IDU	Indoor ambient temperature	AI	(N-1)*256+131072	Actual value(°C):-30~138
	Temperature setting	AV	(N-1)*256+131072	Actual value(°C):16.0~30.0
	Lower limit temperature setting for cooling energy saving	AV	(N-1)*256+131073	Actual value(°C):16.0~30.0
	Lower limit temperature setting for heating energy saving	AV	(N-1)*256+131074	Actual value(°C):16.0~30.0
	Communication error between gateway and IDU	BI	(N-1)*256+131074	0: No, 1: Yes
	IDU general error	BI	(N-1)*256+131075	0: No, 1: Yes
	Indoor fan protection	BI	(N-1)*256+131077	0: No, 1: Yes
	Full water protection	BI	(N-1)*256+131078	0: No, 1: Yes
	Malfunction of indoor circuit board	BI	(N-1)*256+131082	0: No, 1: Yes
	Ambient temperature sensor malfunction	BI	(N-1)*256+131084	0: No, 1: Yes
	Inlet temperature sensor malfunction	BI	(N-1)*256+131085	0: No, 1: Yes
	Outlet temperature sensor malfunction	BI	(N-1)*256+131086	0: No, 1: Yes
	Communication malfunction	BI	(N-1)*256+131088	0: No, 1: Yes
	Engineering number conflict of IDU	BI	(N-1)*256+131089	0: No, 1: Yes
	Missing main IDU	BI	(N-1)*256+131090	0: No, 1: Yes
One controller for multiple units, and the number of IDU is inconsistent (HBS network)	BI	(N-1)*256+131091	0: No, 1: Yes	

	ON/OFF	BV	(N-1)*256+131072	0: Off、1: On
	Operation mode setting	MV	(N-1)*256+131072	Actual value: 1:Invalid; 2:Cooling; 3:Dehumidifying; 4:Fan; 5:Heating; 6:Auto; 7:Floor heating; 8:Rapid heating; 9:Heat supply
	Fan speed setting	MV	(N-1)*256+131073	Actual value: 1:Invalid; 2:Auto fan speed; 3:Low; 4:Medium-low; 5:Medium; 6:Medium-high; 7:High; 8:Turbo; 9:Fan stop
ODU	Communication malfunction between gateway and ODU	BI	(N-1)*256+262144	0: No、1: Yes
	High pressure protection	BI	(N-1)*256+262149	0: No、1: Yes
	Low pressure protection	BI	(N-1)*256+262150	0: No、1: Yes
	High discharge temperature protection	BI	(N-1)*256+262151	0: No、1: Yes
	Overload protection	BI	(N-1)*256+262152	0: No、1: Yes
	High pressure sensor malfunction	BI	(N-1)*256+262156	0: No、1: Yes
	Low pressure sensor malfunction	BI	(N-1)*256+262157	0: No、1: Yes
	Discharge sensor malfunction	BI	(N-1)*256+262158	0: No、1: Yes
	Capacity match abnormal	BI	(N-1)*256+262159	0: No、1: Yes
	Subcooler sensor malfunction	BI	(N-1)*256+262161	0: No、1: Yes
	Fan drive board malfunction	BI	(N-1)*256+262163	0: No、1: Yes
	Compressor drive board malfunction	BI	(N-1)*256+262164	0: No、1: Yes
	Pressure sensor malfunction	BI	(N-1)*256+262177	0: No、1: Yes
	General malfunction of ODU	BI	(N-1)*256+262178	0: No、1: Yes
	Compressor operation status	BI	(N-1)*256+262179	0: Off、1: On
Emergency operation mode	MI	(N-1)*256+262145	Actual value: 1:Invalid; 2:No emergency operation; 3:Emergency operation of compressor; 4:Emergency operation of fan; 5:Emergency operation of module	

## **Chapter 2: Modbus Protocol**

This protocol specifies the communication format and data format for the Modbus communication of Multi VRF (CAN) Series and Energy recovery ventilation system.

**This protocol is applicable to Multi VRF (CAN) Series, including GMV5 , GMV5C , GMV5 MAX , GMV5HR , GMV5 SLIM , GMV5 MINI, GMV6, Energy recovery ventilation system.**

- ✚ Please pay attention to the following 3 points before developing the BMS software:
1. Make sure you have read Chapter 5, Precautions before the Use of Modbus Gateway.
  2. Make sure you have read 4.2: Precautions before the Development of BMS Interface.
  3. Please contact Gree to confirm the compatibility with BMS system.

✚ Notice:

This product is subject to change without prior notice.

## 1 Terms and Definitions

### 1.1 Modbus Communication

Modbus is a kind of industrial communication protocol for distributed control system. Modbus network is a master-slave network which allows the communication between one master unit and one or multiple slave units to realize data interchange. The Modbus communication is realized in a request-response way, that is, each request sent by the master unit is corresponding to a response replied by a slave unit.

### 1.2 ASCII Mode

Under this mode, as for the communication via Modbus, 8 bits in one piece of information can be transmitted as 2 ASCII characters.

### 1.3 RTU Mode

Under this mode, 8 bits can be divided into 2 4-bit hexadecimal characters. The advantage of RTU mode is that, with the same baud rate the transmitted character density is higher than that in ASCII mode. Each piece of information must be transmitted continuously.

### 1.4 TCP Mode

Compared with ASCII mode and RTU mode, TCP mode can achieve data size concurrency.

### 1.5 Master Unit

It indicates the device which sends the Modbus request, such as a PC.

### 1.6 Slave Unit

It indicates the device which provides Modbus communication interface and is capable of responding to the request sent by the master unit, for example, a Modbus gateway. For the convenience of explanation, Modbus gateway is taken as an example in this protocol.

### 1.7 Coil

It is expressed by 1 bit, such as the switch bit, failure bit, etc. The coil is a universal expression of Modbus protocol. It is actually a 1-bit data value, i.e. Boolean, switching value.

### 1.8 Register

It is expressed by 2 bytes (16 bits), such as temperature, mode, etc. The register is a universal expression of Modbus protocol. It is actually a word (16 bits), an analog value.

### 1.9 Device Address

It indicates the address of Modbus gateway, through which the master unit can identify the Modbus gateway in the network. Address range: 1~255. Address 0 is the address of broadcast (received by all Modbus gateways).

### 1.10 Broadcast

When the master unit sends out a control frame (control frame only), all slave units in the network can receive it and then performs the control action (without reply). The device address for broadcast frame is 0.

### 1.11 Function Code

It is used to identify the function of communication frame. See the following table for the function codes covered in this protocol.

Table 1 Function Code

Description	Function Code
Read coil (read bit)	0x01
Read register (read word)	0x03

Write coil (write bit)	0x0f
Write register (write word)	0x10

### 1.12 Starting Address

It indicates the starting address of the register (coil: bit address; register: word address). The data translation starts from the high-order 8 bits to the low-order 8 bits.

### 1.13 Data Size

It indicates the counting number of to-be-operated data starting from the starting address (coil: bit count; register: word count). The data translation starts from the high-order 8 bits to the low-order 8 bits.

### 1.14 Byte Count

It indicates the count number of effective bytes during data transmission.

### 1.15 Effective Data

It indicates the control data, status data, etc.

### 1.16 Error Code

It indicates the error type which is detected and fed back by Modbus gateway when the master unit sends a request frame.

### 1.17 CRC

It indicates the cyclic redundancy code consisting of two bytes. The data translation starts from the low-order 8 bits to the high-order 8 bits. See Annex A for more details about its calculation.

### 1.18 Request Frame

It is the request sent by the master unit to Modbus gateway.

### 1.19 Response Frame

It is the response replied by Modbus gateway to the request frame sent by the master unit.

### 1.20 Communication Frame

It is the collection of continuously transmitted bytes during the communication.

### 1.21 BMS

Building Management System

## 2 Brief Introduction of BMS

The interface RS485 of Modbus RTU Communication Protocol, provided by the long-distance monitoring system, can be directly connected with the Building Management System to realize control over the units and display of their running status. The control function of BMS/PC is equal to that of the unit. In other words, BMS/PC and the unit can both control the functions of unit. However, the command sent later takes the priority.

## 3 Modbus Protocol Format

### 3.1 General

Modbus has actually become an industrial communication standard because it is not only fully open and used widely but also simple and can be debugged flexibly. Besides, as for the communication of multiple units, Modbus can be developed fast and also can be conveniently connected with devices which support this protocol. There are two communication modes: RTU and ASCII. The former one is adopted for the BMS interface.

### 3.2 Protocol Interface

Modbus RTU Protocol

Modbus TCP Protocol

### 3.3 Hardware Interface

#### 3.3.1 Modbus RTU Mode

1) Communication interface: RS485

2) Communication mode:

Baud rate: 9600bit/s



Start bit: 1  
 Data bit: 8  
 Check bit: none  
 Stop bit: 1

### 3.3.2 Modbus TCP Mode

- 1) Ethernet interface
- 2) The port number is 502

## 3.4 Modbus communication frame format

### 3.4.1 Universal Communication Frame Format of Modbus under RTU Mode

Start Time Interval	Addr Code	Function Code	Data Area	CRC	Stop Time Interval
T1-T2-T3-T4	1 Byte	1 Byte	n Bytes	2 Bytes	T1-T2-T3-T4

Under RTU mode, there is at least 3.5ms dead time before data transmission, which can be figured through the adopted baud rate (like T1-T2-T3-T4 in the table above) and there is another 3.5ms dead time after the transmission of the last character. After that, another set of data can be transmitted

The whole set of data should be transmitted continuously. If there is a pause more than 1.5ms during the transmission, the receiver will jump to the transmission of the next set of data.

If the dead time is less than 3.5ms, the transmission will fail as the CRC for communication combination is ineffective.

### 3.4.2 Modbus TCP mode general communication frame format

Transaction Mark	Protocol Mark	Data length	Address Code	Function Code	Data Area
2 Bytes	2 Bytes	2 Byte	1 Byte	1 Byte	n Bytes

The message header is 7 bytes long:

Transaction Mark: User-defined, the default is 0; used for transaction matching. In the response, the Modbus server replicates the transaction identifier of the request; it is used to establish a connection between the request and future responses. Therefore, for TCP connections, at the same time, this identifier must be unique

Protocol Mark: 0; used for multiplexing within the system. The Modbus protocol is recognized by the value 0.

Data length: Address Code + Function Code + Data Area

Address Code: Device Addr

Function code: Read Coil: 0x01

Write Coil: 0x0F

Read Register: 0x03

Write Register: 0x10

Data Area: Including starting addr, offset, control parameters, etc.

## 3.5 Modbus Standard Protocol Format

### 3.5.1 Coil (Bit)

Table2 Coil Data

Addr	Corresponding Byte	Values
Bit 0	Byte0.0	1

Bit 1	Byte0.1	0
Bit 2	Byte0.2	1
Bit 3	Byte0.3	0
Bit 4	Byte0.4	1
Bit 5	Byte0.5	0
Bit 6	Byte0.6	1
Bit 7	Byte0.7	0
Bit 8	Byte1.0	1
Bit 9	Byte1.1	0
Bit 10	Byte1.2	1
Bit 11	Byte1.3	0
Bit 12	Byte1.4	1
Bit 13	Byte1.5	0
Bit 14	Byte1.6	1
Bit 15	Byte1.7	0
.....	.....	.....

1. Coil indicates the data of some flag bit or failure bit, etc. It is expressed by one bit.
2. The unit of data is bit and each bit has a corresponding address.
3. Data bit exists in the byte of communication frame and each byte is composed of 8 bits. The high-order byte is corresponding to the high-order bit whereas the low-order byte is corresponding to the low-order bit. See table 2 for more details.
4. The master unit can operate one bit or multiple bits among the Modbus gateway data at the same time.
5. The bit count which the master unit can read or transmit is less than  $\text{byte} \times 8$ . The ineffective data bit of the last byte must be cleared when the effective data of communication frame is transmitted or read. For instance, when 9 bits (the value of each is 1) are read or transmitted, then 2 bytes are needed. The first one is "1111 1111" and the second one is "0000 0001". For the last byte, the ineffective bits are cleared.

### 3.5.2 Register (Word, 16 Bit)

Table 3 Register Data

Addr	Corresponding Byte	Values
Word 0	Byte 0	AA 55
	Byte 1	
Word 1	Byte 2	AA 55
	Byte 3	
Word 2	Byte 4	55 AA
	Byte 5	
.....	.....	.....
	.....	

1. The unit of register is “word”, which has a corresponding address starting from 0.
2. When the master unit reads a word, it needs to read 2 bytes from the high order 8 bits to the low-order 8 bits.
3. When the master unit transmits or reads the request frame, it can transmit or read one or multiple continuous words in the data list.

### 3.5.3 Modbus RTU mode example

#### 3.5.3.1 Read Coil (Read Bit)

Note: it can read coil data but do not support the broadcast.

Function code: 0x01

Table 4 Request Frame

Device Addr	Function Code	Starting Addr.	Data Size	CRC
1 Byte	1 Byte	2 Bytes	2 Bytes	2 Bytes

Table 5: Corresponding Frame

Device Addr.	Function Code	Byte Count	Effective Data	CRC
1 Byte	1 Byte	1 Byte	n Bytes	2 Bytes

Starting address: it is the starting place where to read a series of

bits. Data size: it indicates the count number of bits.

For example: read 10 bits from Coil 5 of Device 10 (see table 2 for Coil Data), as follows:

Request frame: 0A (device address) 01 (function code) 00 05 (starting address) 00 0A (data size) AD 77 (CRC)

Response frame: 0A (device address) 01 (function code) 02 (byte count) AA 02 (effective data) E3 5C (CRC) The last byte is “0000 0010”, among which the ineffective bits are the bits ahead of “10”.

Ineffective bits must be cleared.

#### 3.5.3.2 Write Coil (Write Bit)

Note: the master unit writes coil data into Modbus gateway and it supports the broadcast.

Function code: 0x0F

Table 6 Request Frame

Device Addr	Function Code	Startng Addr	Data Size	Byte Count	Effective Data	CRC
1 Byte	1 Byte	2 Bytes	2 Bytes	1 Byte	n Bytes	2 Bytes

Table 7 Response Frame

Device Addr	Function Code	Starting Addr.	Data Size	CRC
1 Byte	1 Byte	2 Bytes	2 Bytes	2 Bytes
Note: the response frame has the same device address, same function code, same starting address and same data size as the request frame.				

For example: Set 11 consecutive bits to “1” from Device 10, starting at the address 6, as follows:

Request frame: 0A (device address) 0F (function code) 00 06 (starting address) 00 0B(data size) 02  
(byte count) FF 07 (effective data) 97 A0 (CRC)

Response frame: 0A (device address) 0F (function code) 00 06 (starting address) 00 0B (data size) F5  
76 (CRC)

The last byte is "0000 0111", among which the ineffective bits are the bits ahead of "111". Ineffective bits must be cleared.

### 3.5.3.3 Read Register (Read Word)

Note: it can read register data of Modbus gateway but do not support the broadcast.

Function code: 0x03

Table 8 Request Frame

Device Addr	Function Code	Starting Addr.	Data Size	CRC
1 Byte	1 Byte	2 Bytes	2 Bytes	2 Bytes

Table 9 Response Frame

Device Addr	Function Code	Byte Count	Effective Data	CRC
1 Byte	1 Byte	1 Byte	n Bytes	2 Bytes

Starting address: it indicates the starting address to read word data block.

Data size: it indicates the count number of words with the maximum of 127 each time. For example: Read 2 continuous words (see table 3 for Register Data), as follows:

Request frame: 0A (device address) 03 (function code) 00 01 (starting address) 00 02 (data size) 94 B0  
(CRC)

Response frame: 0A (device address) 03 (function code) 04 (byte count) AA 55 55 AA (effective data)  
CE 14 (CRC)

### 3.5.3.4 Write Register (Write Word)

Note: write control data from the master unit into the register and it supports the broadcast.

Function code: 0x10

Table 10 Request Frame

Device Addr	Function Code	Starting Addr.	Data Size	Byte Count	Effective Data	CRC
1 Byte	1 Byte	2 Bytes	2 Bytes	1 Byte	n Bytes	2 Bytes

Table 11 Response Frame

Device Addr	Function Code	Starting Addr.	Data Size	CRC
1 Byte	1 Byte	2 Bytes	2 Bytes	2 Bytes
Note: the response frame has the same device address, same function code, same starting address and same data size as the request frame				

For example: Write 3 words (0x12, 0x23, 0x34) into Device 10, starting at the address 2, as follows:

Request frame: 0A (device address) 10 (function code) 00 02 (starting address) 00 03 (data size) 06 (byte  
count) 00 12 00 23 00 34 (effective data) 15 DF (CRC)

Response frame: 0A (device address) 10 (function code) 00 02 (starting address) 00 03 (data size) 20  
B3 (CRC)

### 3.5.3.5 Error Response

Note: the master unit sends out a request frame in order to receive a normal response, but when Modbus gateway detects an error, an error response will be sent back.

Function code: the highest bit of the function code of request frame is set to “1”, which is the value figured through the operation of the function code of request frame with 0x80 (the function code of normal response will be back as it is).

Communication format of the error response frame:

Table 12 Error Response Frame

Device Addr.	Function Code	Error Code	CRC
1 Byte	1 Byte	1 Bytes	2 Bytes

Description of error codes:

Table 13 Error Codes

Error Code	Name	Description
0x03	Illegal data	The transmitted data is incorrect or beyond the data range.
0x04	Slave device failure	Communication failure occurs between Modbus gateway and the air conditioning unit.

For example: The master unit is to read 128 words from Device 10, starting at the address 0. If it is out of the readable range of Modbus, error frame will be sent back as follows:

Request frame: 0A (device address) 03 (function code) 00 00 (starting address) 00 80 (data size) 45 11 (CRC)

Response frame: 0A (device address) 83 (function code) 03 (error code) 70 F3 (CRC)

### 3.5.4 Modbus TCP mode example

#### 3.5.4.1 Read Coil (Read Bit)

Function code: 0x01

Table 4 Request Frame

Transaction Mark	Protocol Mark	Data length	Device Addr	Function Code	Starting Addr	Data Size
2 Bytes	2 Bytes	2 Bytes	1 Byte	1 Byte	2 Bytes	2 Bytes

Table 5 Corresponding Frame

Transaction Mark	Protocol Mark	Data length	Device Addr	Function code	Byte Count	Effective Data
2 Bytes	2 Bytes	2 Bytes	1 Byte	1 Byte	1 Bytes	n Bytes

Starting Addr: it is the starting place where to read a series of bits.

Data quantity: The number of bits to be read, up to 2040 bits can be read each time.

For example: read 10 bits from Coil 5 of Device 10 (see table 2 for Coil Data), as follows:

Request Frame: 00 00 00 00 00 06 0A 01 00 05 00 0A

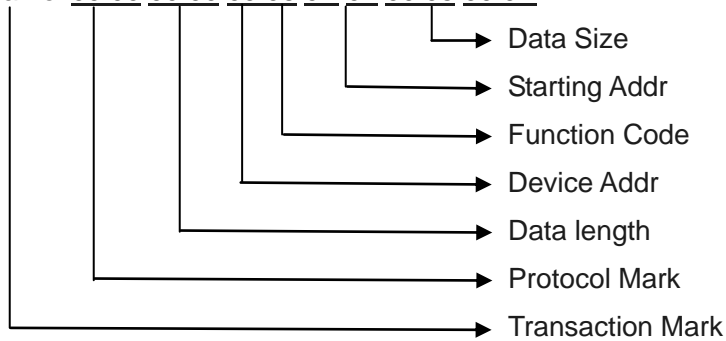

Corresponding Frame: 00 00 00 00 00 05 0A 01 02 AA 02

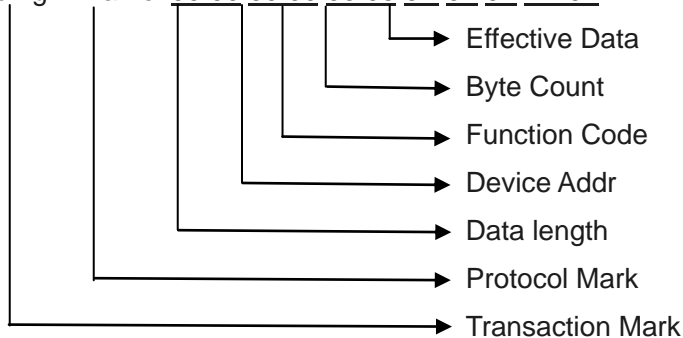

The last byte is "0000 0111", among which the ineffective bits are the bits ahead of "111". Ineffective bits must be cleared.

### 3.5.4.2 Write Coil (Write Bit)

Function Code: 0x0F

Table 6 Request Frame

Transaction Mark	Protocol Mark	Data length	Device Addr	Function Code	Starting Addr	Data Size	Byte Count	Effective Data
2 Bytes	2 Bytes	2 Bytes	1 Byte	1 Byte	2 Bytes	2 Bytes	1 Byte	n Bytes

Table 7 Corresponding Frame

Transaction Mark	Protocol Mark	Data length	Device Addr	Function Code	Starting Addr	Data Size
2 Bytes	2 Bytes	2 Bytes	1 Byte	1 Byte	2 Bytes	2 Bytes

Note: the response frame has the same device address, same function code, same starting address and same data size as the request frame.

For example: Set 11 consecutive bits to “1” from Device 10, starting at the address 6, as follows:

Request Frame: 00 00 00 00 00 09 0A 0F 00 06 00 0B 02 FF 07

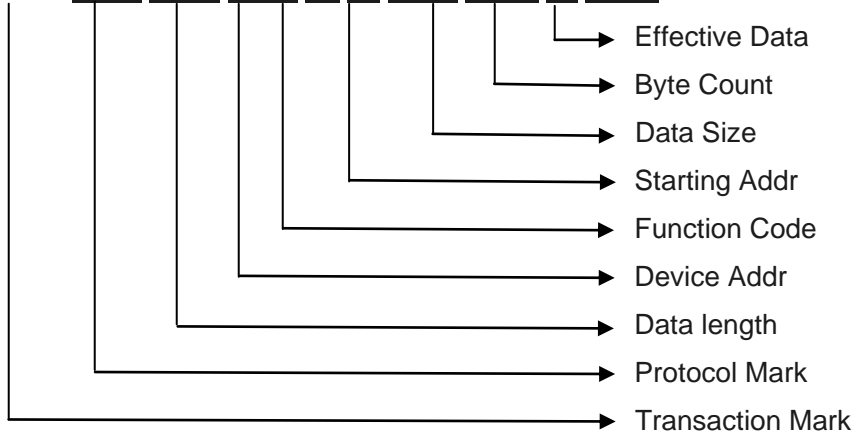

Corresponding Frame: 00 00 00 00 00 06 0A 0F 00 06 00 0B

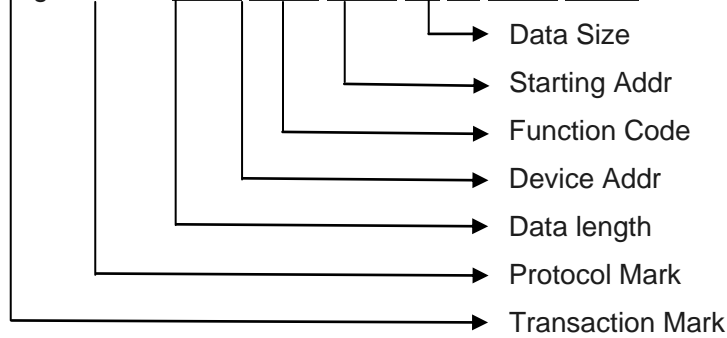

The last byte is “0000 0111”, among which the ineffective bits are the bits ahead of “111”. Ineffective bits must be cleared.

### 3.5.4.3 Read Register (Read Word)

Function Code: 0x03

Table 8 Request Frame

Transaction Mark	Protocol Mark	Data length	Device Addr	Function Code	Starting Addr	Data Size
2 Bytes	2 Bytes	2 Bytes	1 Byte	1 Byte	2 Bytes	2 Bytes

Table 9 Corresponding Frame

Transaction Mark	Protocol Mark	Data length	Device Addr	Function Code	Byte Count	Effective Data
2 Bytes	2 Bytes	2 Bytes	1 Byte	1 Byte	1 Byte	n Bytes

Starting Addr: it indicates the starting address to read word data block.

Data size: it indicates the count number of words with the maximum of 127 each time.

For example: Read 2 continuous words (see table 3 for Register Data), as follows:

Request Frame: 00 00 00 00 00 06 0A 03 00 01 00 02

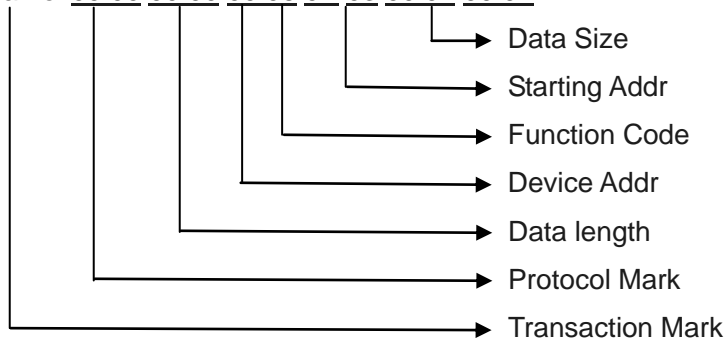

Corresponding Frame: 00 00 00 00 00 07 0A 03 04 AA 55 55 AA

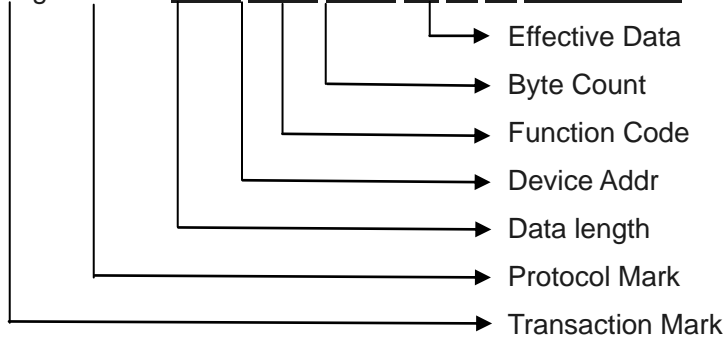



### 3.5.4.4 Write Register (Write Word)

Function Code: 0x10

Table 10 Request Frame

Transaction Mark	Protocol Mark	Data length	Device Addr	Function Code	Starting Addr	Data Size	Byte Count	Effective Data
2 Bytes	2 Bytes	2 Bytes	1 Byte	1 Byte	2 Bytes	2 Bytes	1 Byte	n Bytes

Table 11 Corresponding Frame

Transaction Mark	Protocol Mark	Data length	Device Addr	Function Code	Starting Addr	Data Size
2 Bytes	2 Bytes	2 Bytes	1 Byte	1 Byte	2 Bytes	2 Bytes

Note: the response frame has the same device address, same function code, same starting address and same data size as the request frame

For example: Write 3 words (0x12, 0x23, 0x34) into Device 10, starting at the address 2, as follows:

Request Frame: 00 00 00 00 00 09 0A 10 00 02 00 03 06 00 12 00 23 00 34

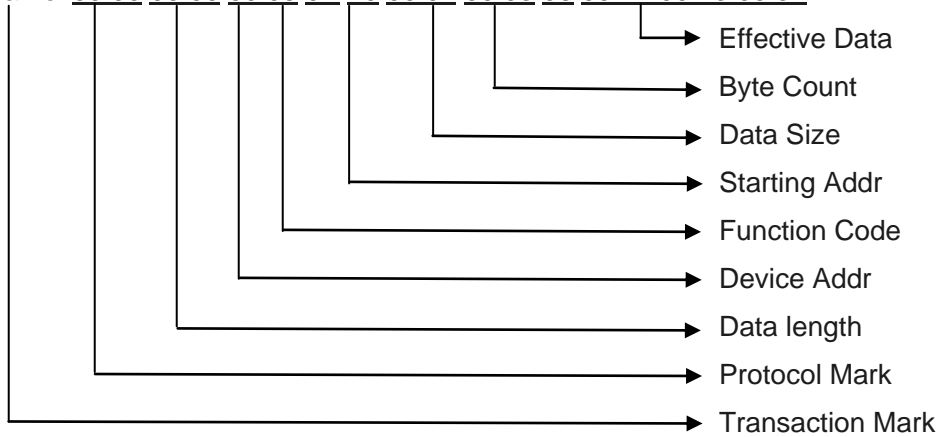

Corresponding Frame: 00 00 00 00 00 06 0A 10 00 02 00 03

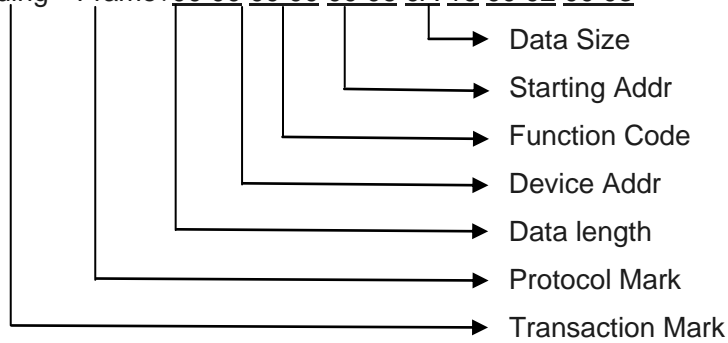

### 3.5.4.5 Error Response

Note: the master unit sends out a request frame in order to receive a normal response, but when Modbus gateway detects an error, an error response will be sent back.

Function code: the highest bit of the function code of request frame is set to “1”, which is the value figured through the operation of the function code of request frame with 0x80 (the function code of normal response will be back as it is).

Table 12 Error Corresponding Frame

Transaction Mark	Protocol Mark	Data length	Device Addr	Function Code	Error Code
2 Bytes	2 Bytes	2 Bytes	1 Byte	1 Byte	1 Bytes

Description of error codes:

Table 13 Error Codes

Error Code	Name	Description
0x03	Illegal data	The transmitted data is incorrect or beyond the data range.
0x04	Slave device failure	Communication failure occurs between gateway and the air conditioning unit.

For example: The master unit is to read 128 words from Device 10, starting at the address 0. If it is out of the readable range of Modbus, error frame will be sent back as follows:

Request Frame: 00 00 00 00 00 06 0A 03 00 00 00 80

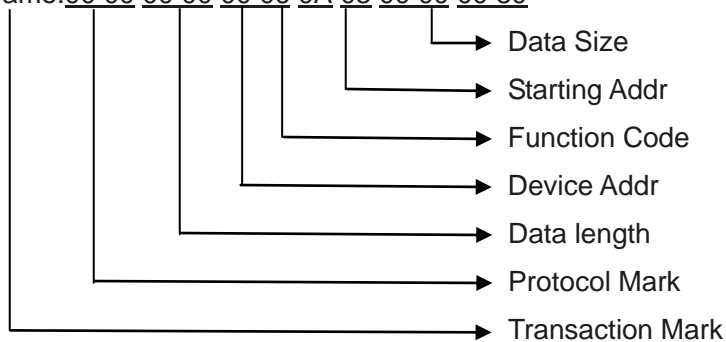

Corresponding Frame: 00 00 00 00 00 03 0A 83 03

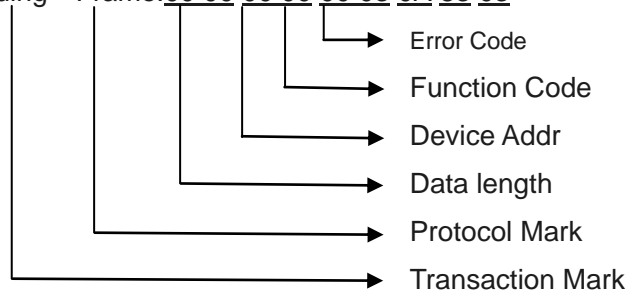

## 4 Communication Protocol for CAN Series Unit

### 4.1 General

Can Series Unit have been integrated with BMS interface that supports Modbus protocol. The long-distance monitoring system can be used to monitor Gree Multi VRF Units (concrete models shall refer to the preface) and Energy recovery ventilation system, or be incorporated into the BMS system on user side. By monitoring the PC or BMS system, user can realize a centralized management and control over the units. It is a highly efficient tool for the management of an intelligent air conditioning system in modern buildings.

This interface can not only realize long-distance monitoring over the units, including units' running temperature, compressor status and error status, but also can enable settings remotely, such as temperature setting, mode setting, on/off setting, mode shield, On/Off shield, etc.

- ✚ In this protocol, "R" indicates "read only", "W" indicates "write only" and "W/R" indicates "write and read".

### 4.2 Precautions before the Development of BMS Interface

Before the development of BMS interface, please make sure the DIP switch of Modbus gateway is correctly set and wired.

#### Precautions for the design of BMS software:

★ (1) :If the mode set by BMS software is in conflict with the cooling/heating function of outdoor unit, it will be ineffective. We recommend enabling the indication of ineffective operation on the monitoring software:

If the outdoor unit provides cooling function only, heating/floor heating/warming/fast heating will be ineffective

If the outdoor unit provides heating function only, cooling/drying will be ineffective;

If the outdoor unit provides fan ventilation only, any mode except fan/fresh air will be ineffective.

★ (2) :If the indoor unit mode set by BMS software is in conflict with the mode of master indoor unit, it will be ineffective; floor heating/warming/fast heating will be effective only for models that are designed with these functions.

★ (3) :When the format of error response frame received by BMS system is 0x04, it indicates that there is communication failure between units and the gateway.

★ (4) :Energy saving solution

When the "energy-saving" parameter is enabled, all kinds of temperature lower limit and upper limit will be effective.

Temperature lower limit under cooling: If the setting for energy saving is enabled, the temperature set by BMS software will be effective only when it is higher than the temperature lower limit for energy saving; otherwise, units will not respond to the command. We recommend enabling the indication of ineffective operation on BMS software. The principles of temperature lower limit and upper limit under drying mode, fast heating mode and warming mode are the same.

Temperature upper limit under heating: If the setting for energy-saving is enabled, the temperature set by BMS software will be effective only when it is lower than the temperature upper limit for energy saving; otherwise, units will not respond to the command. We recommend enabling the indication of ineffective operation on BMS software.

★ (5) :All the data sent by BMS software to the gateway must be verified to see if they are effective.

★ (6) :After the gateway is powered on and before receiving any effective data, error code 04 will be reported if BMS software requests for data.

★ (7) :Any compulsory mode of outdoor unit takes priority over the control of BMS software. Under compulsory mode, the control of BMS software will be ineffective.

★ (8) :Long-distance lock

It can be set under any condition;

Under the status of long-distance lock, compulsory mode of outdoor unit and hardware reset of indoor unit can be effective.

## ★ (9) :On/Off

If power supply is insufficient so that units have to be shut off compulsorily (error code L8 is displayed), the command of Unit On sent by BMS software will be ineffective.

For any other cases, the command of Unit On/Off sent by BMS software can be effective.

★ (10) :Long-distance On/Off shield, On shield, Off shield Above settings can be enabled under any condition.

Under any of these three settings, indoor unit timer will be temporarily ineffective (timer icon stays) and cannot be set, but it can be canceled by remote control;

## ★ (11) :8° heating function (i.e. absence mode)

This function can be effective only under heating mode. When the unit turns to other modes, it will exit from 8° heating function (i.e. absence mode);

8° heating function (i.e. absence mode) and long-distance temperature shield are mutually exclusive, whichever comes first will be effective; in other words, if long-distance temperature shield has been set, then 8° heating function (i.e. absence mode) cannot be set; if the indoor unit is already working with 8° heating function (i.e. absence mode), long-distance temperature shield will be ineffective;

## ★ (12) :Low temperature drying

It will be effective only under drying mode. If the unit turns to other modes, it will exit from low temperature drying;

Low temperature drying and long-distance temperature shield are mutually exclusive, same as the case for 8° heating function (i.e. absence mode).

Under low temperature drying, set temperature must be 12°.

## ★ (13) :Set temperature

When the unit is under the status of 8° heating function (i.e. absence mode) or low temperature drying, set temperature must be 8° or 12° and temperature set by BMS software will be ineffective.

When indoor units are under energy saving mode, the temperature set by BMS software will be ineffective if it is out of temperature limits (for example, in case that the temperature lower limit for energy

saving in cooling mode is 20°, if the temperature set by BMS software is lower than 20°, it will be ineffective); if BMS software sets temperature shield, then energy saving function will be temporarily ineffective and units will respond to the command of set temperature sent by BMS software.

## ★ (14) :Shield temperature setting

Temperature setting shield is mutually exclusive with absence mode (8° heating function) and low temperature drying (whichever comes first will be effective);

Under temperature setting shield, energy saving function will be temporarily ineffective; Under temperature setting shield, sleep function will be canceled and cannot be set.

## ★ (15) :Energy saving and its temperature limits Under fan mode, energy saving setting is ineffective;

Under temperature setting shield, energy saving function will be temporarily ineffective (energy saving icon stays);

Temperature limits for energy saving are effective under any condition.

## ★ (16) :Shield energy saving It can be set under any condition.

## ★ (17) :Fan speed

Under drying mode, low fan speed is compulsory. BMS software cannot enable any other speed;

When BMS software is setting fan speed, if indoor unit is under turbo or compulsory quiet status, it will exist from such status; if indoor unit is set with 8° heating function (i.e. absence mode), fan speed must be auto speed only;

If the indoor unit is designed with a 3-speed fan motor, the five speed commands sent by BMS software should be interpreted like this: low speed and low-medium speed both refer to low speed; medium speed is medium speed; medium-high speed and high speed both refer to high speed;

## ★ (18) :Turbo

This setting can be effective only under cooling/heating mode.

Under the status of 8° heating function (i.e. absence mode), turbo mode cannot be set;

When indoor unit is running in quiet mode and BMS software enables turbo running, indoor unit will respond

to this setting and exit from quiet mode.

★ (19) :Quiet

Quiet setting is ineffective under drying/fan mode.

Under the status of 8° heating function (i.e. absence mode), quiet mode cannot be set;

When indoor unit is in turbo running status and BMS software enables quiet setting, indoor unit will respond to this setting and exit from turbo running status.

★ (20) :X-Fan

It will be effective only when the unit is running in cooling/drying mode. If the unit turns to other modes, X-Fan will not be canceled.

★ (21) :Air

Air function set by BMS software will be effective under any condition.

If the unit is powered off by hand (including BMS software) or by timer, air function will be off;

★ (22) :Reminder and clearing of filter cleaning: both can be set under any condition;

★ (23) :Shield timer

It can be set under any condition.

Under timer shield, indoor unit timer will be temporarily ineffective (timer icon stays); timer will not be displayed and cannot be set; when timer shield is canceled, timer function will be restored;

★ (24) :Auxiliary heating forbiddance It can be set under any condition.

For export models, auxiliary heating control function and forbiddance function are not applicable.

★ (25) :Data time sequence requirement

The master unit should reserve effective wait time according to data length and communication baud rate to avoid conflict caused by short wait time of long frame.

★ (26) :Left&right swing

Parameters of left&right swing are different for different indoor unit models.

★ (27) :

DC Inverter GMV Water Cool Heat Pump unit is without this parameter

★ (28) :

Add for Malaysia.

★ (29) :

There's only one main air box. Several main air boxes can't be set.

★ (30) :Change of RS485 Baud Rate

It's not effective until gateway restart.

### 4.3 Definitions of Effective Data

Data for Modbus communication protocol can be divided into two types: switching value and register. The latter one indicates the values of temperature, valves and other continuous or multi-mode values, while the former one indicates the value which has two kinds of status only, for example, the temperature sensor error has two kinds of status: abnormal and normal.

Address	Access Type	Data Meaning	Range	Accuracy	Unit	Data Type	Remarks	Notices
89	R	Communication protocol version	Transmission value=actual value, actual value: 1.00~10.00	/	/	UINT16		
90	R	Hardware version	Transmission value=actual value, actual value: 1.00~10.00	/	/	UINT16		
91	R	Software version	Transmission value=actual value, actual value: 1.00~10.00	/	/	UINT16		
92	W/R	RS485 Baud Rate	Transmission value=actual value, actual value: 4800,9600,19200,38400	/	bps	UINT16		★(30)

Address	Access Type	Data Meaning	Range	Parameter type	Remarks	Notices
88 +(m-1)	R	System m with/with out	0: without, 1: with	Status parameter	$1 \leq m \leq 16$	
120 +(n-1)	R	IDU n with/with out	0: without, 1: with	Status parameter	$1 \leq n \leq 255$	
409 +64*(n-1)	R	Communication error between gateway and IDU	0: no, 1: yes	Error parameter	$1 \leq n \leq 255$	
16801 +48*(n-1)	R	Communication error between gateway and ODU	0: no, 1: yes	Error parameter	$1 \leq m \leq 16$	

## 4.3.1 ODU and IDU of Multi VRF Units

Table 3: Data and address distribution of the analog values of ODU and ordinary air-condition IDU Range: Word 102~Word 8239								
Address	Access Type	Data Meaning	Range	Accuracy	Unit	Data Type	Remarks	Notices
102 +25*(n-1)	W/R	Power on /Power off	Transmission value =actual value, actual value: power on: 0xAA; power off: 0x55;	/	/	UINT16	Data of indoor unit n, 1≤n≤255	★(9)
103 +25*(n-1)	W/R	Operation mode	<b>【Setting】 :</b> Transmission value =actual value, actual value: 0:invalid; 1:cooling; 2:dehumidifying; 3:fan; 4: heating; 5:auto; 6: floor heating; 7: quick heating; 8: heat supply; 9: clothes drying; 0A: air discharge; 0B: auto dehumidifying;  <b>【Read】 :</b> 01: cooling; 02:dehumidifying; 03:fan; 04: heating; 05:auto cooling; 06:auto heating; 07:floorheating; 08:quick heating; 09:heat supply; 0A: clothes drying; 0B: air discharge; 0C: auto dehumidifying;	/	/	UINT16		★(2)
104 +25*(n-1)	W/R	Temperature	Transmission value =actual value×10, actual value: 16.0~30.0;	1	℃	UINT16		★(13)

105 +25*(n-1)	W/R	Fan speed	<b>【Setting】 :</b> Transmission value = actual value, actual value: 0: invalid; 1: auto fan speed; 2: low fan speed; 3: Medium low fan speed; 4: Medium fan speed; 5: Medium high fan speed; 6: High fan speed; 7: Turbo fan speed; <b>【Read】 :</b> 01: fan stops; 02: super low fan speed; 03: low fan speed; 04: medium low fan speed; 05: medium fan speed; 06: medium high fan speed; 07: high fan speed; 08: super high fan speed; 09: quiet fan speed R1; 0A: quiet fan speed R2; 0B: quiet fan speed R3;	/	/	UINT16	★(17) ★(18)
106 +25*(n-1)	W/R	Lower limit temperature of cooling energy saving	Transmission value =actual value×10, actual value: 16.0~30.0	1	°C	UINT16	★(4)
107 +25*(n-1)	W/R	Upper limit temperature of heating energy saving	Transmission value =actual value×10, actual value: 16.0~30.0	1	°C	UINT16	★(4)
108 +25*(n-1)	W/R	Lower limit temperature of dehumidifying energy saving	Transmission value =actual value×10, actual value: 16.0~30.0	1	°C	UINT16	★(4)



109 +25*(n-1)	W/R	Up&down swing	Range: 0~255; 0: invalid; 1: off; 2: swing 15; 3: position 1; 4: position 2; 5: position 3; 6: position 4; 7: position 5; 8: swing 35; 9: swing 25; 10: swing 24; 11: swing 14; 12: swing 13; others: reserved;	/	/	UINT16		
110 +25*(n-1)	W/R	Left&right swing	Range: 0~255; 0: invalid; 1: off; 2: same direction swing; 3: position 1; 4: position 2; 5: position 3; 6: position 4; 7: position 5; 8: swing 35; 9: swing 25; 10: swing 24; 11: swing 14; 12: swing 13; others: reserved;	/	/	UINT16		★(26)
111 +25*(n-1)	W/R	Quiet	0: invalid data; 1: quiet off; 2: auto quiet; 3: quiet;	/	/	UINT16		
112 +25*(n-1)	W/R	Sleep	0: invalid data; 1: sleep off; 2: sleep 1; 3: sleep 2; 4: sleep 3;	/	/	UINT16		
113 +25*(n-1)	W/R	humidity setting	Transmission value =actual value, actual value: 1~100	5	%	UINT16		
114 +25*(n-1)	R	Indoor relative humidity	Transmission value =actual value+100, actual value: 120~190	1	%	UINT16		
							Reserved	

116 +25*(n-1)	R	Indoor ambient temperature	Transmission value =actual value×10, actual value range: -30~138;	0.1	°C	UINT16		
117 +25*(n-1)	R	Gate control status	Transmission value =actual value, actual value: 0: invalid; 1: without gate control; 2: insert card; 3: disconnect card;	/	/	UINT16		
118 +25*(n-1)	R	Outdoor unit number which indoor unit belongs to	Transmission value =actual value, actual value range: 1~16;	/	/	UINT16		
							Reserved	
123 +25*(n-1)	R	Rated capacity of indoor unit	Transmission value =actual value, actual value: 22, 25, 28, 32, 36, 40, 45, 50, 56, 63, 71, 80, 90, 100, 112, 125, 140, 160, 180, 224, 250, 280, 335, 350, 400, 450, 500, 560;	1	Hec tow att	UINT16		
124 +25*(n-1)	W/R	Static pressure value(Motor model for AC)	Transmission value =actual value, actual value: 0: invalid; 1~9: static pressure 1~9;	/	/	UINT16		
125 +25*(n-1)	W/R	Static pressure value(Motor model for DC)	Transmission value =actual value, actual value: 0: invalid; 1~13: static pressure 1~13;	/	/	UINT16		
6502 +10*( m-1)	W/R	Setting upper limit capacity of outdoor unit	Transmission value =actual value, actual value: 30~100;	/	%	UINT16	Data of system m, 1≤m≤16	★(27)
6503 +10*( m-1)	R	Startup quantity of general IDU	Transmission value =actual value, actual value: 0~255;	/	/	UINT16		
							Reserved	

6505 +10*( m-1)	W/R	Demand power percentage upper limit setting	Transmission value =actual value, actual value range: 0, 40~100	1	%	UINT16		
6506 +10*( m-1)	R	Complete unit cooling and heating mode	Transmission value =actual value, actual value: 0: invalid 1: cooling only; 2: heating; 3: cooling and heating; 4: fan;	/	/	UINT16		★(1)
6507 +10*( m-1)	R	Outdoor ambient temperature	Transmission value =actual value×10, actual value range: -30~155;	0.1	℃	UINT16		★(27)
6508 +10*(m-1)	R	Emergency operation mode	Transmission value =actual value, actual value: 1: without emergency operation; 2: emergency operation of compressor; 3: emergency operation of fan; 4: emergency operation of module;	/	/	UINT16		
6666	W	Mode setting of all indoor units	【Setting】 : Transmission value =actual value, actual value: 0: invalid; 1: cooling; 2: dehumidifying; 3:fan; 4: heating; 5: auto; 6: floor heating; 7: quick heating; 8: heat supply;			UINT16	Gateway data	★(2)
6667	W	Temperature setting of all indoor units	Transmission value =actual value×10, actual value: 16.0~30.0;	1	℃	UINT16	Gateway data	★(13)

6668	W	Fan speed setting of all indoor units	<b>【Setting】</b> : Transmission value =actual value, actual value: 0: invalid; 1: auto fan speed; 2: low fan speed; 3: Medium low fan speed; 4: Medium fan speed; 5: Medium high fan speed; 6: High fan speed; 7: Turbo fan speed;	/	/	UINT16	Gateway data	★(17) ★(18)
6669	W	Demand power percentage upper limit setting of all systems	Transmission value =actual value, actual value range: 0, 40~100	1	%	UINT16	Gateway data	
6680 +80*(k - 1) +20*(j - 1)	R	Valid value of input phase voltage at grid side	Transmission value =actual value/2; actual value: 0~510;	/	V	UINT16	Data of module j of system k, 1≤k≤16, 1≤j≤4	
6681 +80*(k - 1) +20*(j - 1)	R	PV DC bus voltage	Transmission value =actual value, actual value: 0~65535;	/	V	UINT16		
6682 +80*(k - 1) +20*(j - 1)	R	Current at grid side	Upper eight bits of transmission value + Lower eight bits of transmission value/256 =actual value; Example: compressor current is 10.8A, integer part sends data of 10, decimal part sends data of 0.8*256=204;	0.1	A	UINT16		
6683 +80*(k - 1) +20*(j - 1)	R	Grid connection power at grid side	Transmission value =(actual value/10 +32768); actual value: -327680~327670;	/	W	UINT16		

6684 +80*(k - 1) +20*(j - 1)	R	Power of PV generated electricity	Transmission value =actual value/10, actual value range: 0~655350;	/	W	UINT16		
6685 +80*(k - 1) +20*(j - 1)	R	Grid connection electricity at grid side	Transmission value =(actual value/1000 +32768); actual value range: -32768000~32767000;	/	WS	UINT16		
6686 +80*(k - 1) +20*(j - 1)	R	PV generated electricity	Transmission value =actual value/1000; actual value range: 0~65535000;	/	WS	UINT16		
6687 +80*(k - 1) +20*(j - 1)	R	Input current at PV side	Upper eight bits of transmission value + Lower eight bits of transmission value/256 =actual value; Example: compressor current is 10.8A, integer part sends data of 10, decimal part sends data of 0.8*256=204;	0.1	A	UINT16		
6688 +80*(k - 1) +20*(j - 1)	W/R	Limited power percentage at PV side	Transmission value =actual value*10	0.1	%	UINT16		★(28)
6689 +80*(k - 1) +20*(j - 1)	R	Power generation at PV side 1 of DC input	Transmission value =actual value/10; actual value range: 0~655350;	/	W	UINT16		
6690 +80*(k - 1) +20*(j - 1)	R	Power generation at PV side 2 of DC input	Transmission value =actual value/10; actual value range: 0~655350;	/	W	UINT16		
6691 +80*(k - 1) +20*(j - 1)	R	Generated electricity at PV side 1 of DC input	Transmission value =actual value/1000; actual value range: 0~65535000;	/	WS	UINT16		
6692 +80*(k - 1) +20*(j - 1)	R	Generated electricity at PV side 2 of DC input	Transmission value =actual value/1000; actual value range: 0~65535000;	/	WS	UINT16		

8000 +15*(k - 1)	R	Running state of MPPT1	Transmission value =actual value; actual value: 0: stop; 1: standby; 2: start; 3: run; >100: abnormal	/	/	UINT16	Data of module 1 of system k, 1≤k≤16	
8001 +15*(k - 1)	R	Running state of MPPT2	Transmission value =actual value; actual value: 0: stop; 1: standby; 2: start; 3: run; >100: abnormal	/	/	UINT16		
8002 +15*(k - 1)	R	generated electricity at grid connection side	Transmission value =actual value; Example: read value = 0x3FAC28F5, float value = 1.345kwh	/	kwh	Float		
8003 +15*(k - 1)								
8004 +15*(k - 1)	R	generated electricity of MPPT1	Transmission value =actual value; Example: read value = 0x3FAC28F5, float value = 1.345kwh	/	kwh	Float		
8005 +15*(k - 1)								
8006 +15*(k - 1)	R	Generating power of MPPT1	Transmission value =actual value; actual value range: 0~65535;	/	W	UINT16		
8007 +15*(k - 1)	R	generated electricity of MPPT2	Transmission value =actual value; Example: read value = 0x3FAC28F5, float value = 1.345kwh	/	kwh	Float		
8008 +15*(k - 1)								
8009 +15*(k - 1)	R	Generating power of MPPT2	Transmission value =actual value; actual value range: 0~65535;	/	W	UINT16		

Table 4: Data and Address Distribution of the Switching Value of VRF ODU and ordinary air-condition IDU Range: Bit 376~Bit 18639						
Address	Access Type	Data Meaning	Range	Parameter type	Remarks	Notices
376	W/R	Remote emergent stop signal of system 1	0: off, 1: on	Status parameter		
376+(m-1)	W/R	Remote emergent stop signal of system m	0: off, 1: on	Status parameter		
391	W/R	Remote emergent stop signal of system 16	0: off, 1: on	Status parameter		
400	W	Set all IDU on	0: no, 1: yes	Status parameter	Gateway data	
401	W	Set all IDU off	0: no, 1: yes	Status parameter	Gateway data	
402	W	Set all IDU locked remotely	0: no, 1: yes	Status parameter	Gateway data	
403	W	Set all IDU unlocked remotely	0: no, 1: yes	Status parameter	Gateway data	
408 +64*(n-1)	R	General error of indoor unit(IDU)	0: no, 1: yes	Error parameter	Data of IDU n, 1≤n≤255	
409 +64*(n-1)	R	Communication error between gateway and IDU	0: no, 1: yes	Error parameter		
410 +64*(n-1)	R	Protection of IDU	0: no, 1: yes	Error parameter		
411 +64*(n-1)	R	Protection of Indoor fan	0: no, 1: yes	Error parameter		
412 +64*(n-1)	R	Water full protection	0: no, 1: yes	Error parameter		
413 +64*(n-1)	R	Overcurrent protection of power supply	0: no, 1: yes	Error parameter		
414 +64*(n-1)	R	Freeze protection	0: no, 1: yes	Error parameter		
415 +64*(n-1)	R	Mode conflict	0: no, 1: yes	Error parameter		
416 +64*(n-1)	R	Failure of indoor circuit board	0: no, 1: yes	Error parameter		
417 +64*(n-1)	R	Error of IDU temperature sensor	0: no, 1: yes	Error parameter		
418 +64*(n-1)	R	Error of ambient temperature sensor	0: no, 1: yes	Error parameter		
419 +64*(n-1)	R	Error of inlet pipe temperature sensor	0: no, 1: yes	Error parameter		

420 +64*(n-1)	R	Error of outlet pipe temperature sensor	0: no, 1: yes	Error parameter		
421 +64*(n-1)	R	Error of humidity temperature sensor	0: no, 1: yes	Error parameter		
422 +64*(n-1)	R	Conflict of IDU project no.	0: no, 1: yes	Error parameter		
423 +64*(n-1)	R	No master IDU	0: no, 1: yes	Error parameter		
424 +64*(n-1)	R	Inconsistency of IDU quantity of one controller for several IDU(HBS network)	0: no, 1: yes	Error parameter		
425 +64*(n-1)	R	Master IDU/slave IDU	0: slave IDU, 1: master IDU	Status parameter		
426 +64*(n-1)	R	Auxiliary electric heater of IDU	0: off, 1: on	Status parameter		
					Reserved	
440 +64*(n-1)	W/R	Remote shielding of energy-saving function	0: no shielded, 1: shielded	Status parameter		
441 +64*(n-1)	W/R	Remote shielding of temperature setting function	0: no shielded, 1: shielded	Status parameter		
442 +64*(n-1)	W/R	Remote shielding of mode function	0: no shielded, 1: shielded	Status parameter		
443 +64*(n-1)	W/R	Remote shielding of power on/power off function	0: no shielded, 1: shielded	Status parameter		
444 +64*(n-1)	W/R	Remote locking function	0: unlocked, 1: locked	Status parameter		
445 +64*(n-1)	W/R	Power supplied for IDU in priority	0: no, 1: yes	Status parameter		
					Reserved	
448 +64*(n-1)	W/R	Energy-saving setting	0: off, 1: on	Status parameter		
449 +64*(n-1)	W/R	Forbidding power on of auxiliary heater	0: allow power on of auxiliary heater, 1: forbid power on of auxiliary heater	Status parameter		
450 +64*(n-1)	W/R	IDU power failure memory	0: standby, 1: power failure memory	Status parameter		
451 +64*(n-1)	W/R	Cancel filter cleaning reminder	0: no, 1: yes	Status parameter		★(22)
452 +64*(n-1)	W/R	Dry	0: off, 1: on	Status parameter		★(20)



					Reserved	
455 +64*(n-1)	W/R	Ventilation	0: off, 1: on	Status parameter		★(21)
456 +64*(n-1)	W/R	Low-temperature dehumidification	0: cancel low-temperature dehumidification 1: start low-temperature dehumidification	Status parameter		★(12)
457 +64*(n-1)	W/R	Shielding on	0: no shielding, 1: shielding	Status parameter		★(10)
458 +64*(n-1)	W/R	Shielding off	0: no shielding, 1: shielding	Status parameter		★(10)
459 +64*(n-1)	W/R	Shielding timer	0: no shielding, 1:shielding	Status parameter		★(23)
460 +64*(n-1)	W/R	Setting 8℃ heating function	0:cancel 8 ℃ heating function, 1:start 8 ℃ heating function	Status parameter		★(11)
16800 +48*(m-1)	R	General error of outdoor unit(ODU)	0: no, 1: yes	Error parameter	Data of System m; 1≤m≤16	
16801 +48*(m-1)	R	Communication error between gateway and ODU	0: no, 1: yes	Error parameter		
16802 +48*(m-1)	R	Air-mixing Protection for 4-way valve of system	0: no, 1: yes	Error parameter		
16803 +48*(m-1)	R	Abnormal pressure ratio of system	0: no, 1: yes	Error parameter		
16804 +48*(m-1)	R	High pressure Protection of system	0: no, 1: yes	Error parameter		
16805 +48*(m-1)	R	High pressure Protection of system	0: no, 1: yes	Error parameter		
16806 +48*(m-1)	R	High discharge temperature protection of system	0: no, 1: yes	Error parameter		
16807 +48*(m-1)	R	Over current protection of system	0: no, 1: yes	Error parameter		

16808 +48*(m-1)	R	Communication error of system	0: no, 1: yes	Error parameter		
16809 +48*(m-1)	R	Outdoor ambient temperature sensor error of system	0: no, 1: yes	Error parameter		
16810 +48*(m-1)	R	Loose error of discharge temperature sensor of system	0: no, 1: yes	Error parameter		
16811 +48*(m-1)	R	High pressure sensor error of system	0: no, 1: yes	Error parameter		
16812 +48*(m-1)	R	Low pressure sensor error of system	0: no, 1: yes	Error parameter		
16813 +48*(m-1)	R	Discharge temperature sensor error of system	0: no, 1: yes	Error parameter		
16814 +48*(m-1)	R	System capacity matching abnormality	0: no, 1: yes	Error parameter		
16815 +48*(m-1)	R	System defrosting temperature sensor error	0: no, 1: yes	Error parameter		
16816 +48*(m-1)	R	System sub-cooler temperature sensor error	0: no, 1: yes	Error parameter		
16817 +48*(m-1)	R	Gas-liquid separator temperature sensor error of system	0: no, 1: yes	Error parameter		
16818 +48*(m-1)	R	Fan drive board error	0: no, 1: yes	Error parameter		
16819 +48*(m-1)	R	Compressor drive board error	0: no, 1: yes	Error parameter		
16820 +48*(m-1)	R	Compressor drive board operation abnormality	0: no, 1: yes	Error parameter		
16821 +48*(m-1)	R	Compressor drive board voltage protection	0: no, 1: yes	Error parameter		
16822 +48*(m-1)	R	Fan drive board Operation abnormality	0: no, 1: yes	Error parameter		

16823 +48*(m-1)	R	Fan drive board voltage protection	0: no, 1: yes	Error parameter		
16824 +48*(m-1)	R	Error of module 1	0: no, 1: yes	Error parameter		
16825 +48*(m-1)	R	Error of module 2	0: no, 1: yes	Error parameter		
16826 +48*(m-1)	R	Error of module 3	0: no, 1: yes	Error parameter		
16827 +48*(m-1)	R	Error of module 4	0: no, 1: yes	Error parameter		
16828 +48*(m-1)	R	Protection for low system high pressure	0: no, 1: yes	Error parameter		
16829 +48*(m-1)	R	Protection for low system discharge temperature	0: no, 1: yes	Error parameter		
16830 +48*(m-1)	R	Error of system pressure sensor	0: no, 1: yes	Error parameter		
16831 +48*(m-1)	R	Other errors	0: no, 1: yes	Error parameter		
16832 +48*(m-1)	R	Start VIP power supply mode	0: no, 1: yes	Status parameter		
16833 +48*(m-1)	R	Unit debugging status	0: normal, 1: debugging	Status parameter		
16834 +48*(m-1)	R	System compress or operation status	0: off, 1: on	Status parameter		
16835 +48*(m-1)	R	ODU system unrecoverable error	0: no, 1: yes	Error parameter		
16836 +48*(m-1)	R	ODU system recoverable error	0: no, 1: yes	Error parameter		
					Reserved	
16840 +48*(m-1)	W/R	Remote energy-saving symbol	0: off, 1: on	Status parameter		
17584 +32*(k-1) +8*(j-1)	R	Grid connection status at grid side	0: off, 1: on	Status parameter	Data of module j of system k; 1≤k≤16, 1≤j≤4	
17585 +32*(k-1) +8*(j-1)	R	MPPT on/off status	0: off, 1: on	Status parameter		

17586 +32*(k-1) +8*(j-1)	R	Limited power at PV side	0: normal, 1: limited	Status parameter		
17587 +32*(k-1) +8*(j-1)	R	Electricity calculation symbol	0: calculation hasn't been done, 1: calculation has been done	Status parameter		
18096 +(i-1)	W/R	IDU i on/off status	0: off, 1: on	Status parameter	Subway IDU i parameter, 1≤i≤255	
18352 +(i-1)	R	IDU i error status	0: normal, 1: with error	Error parameter	Subway IDU i Parameter, 1≤i≤255	
18608 +(j-1)	R	ODU j on/off status	0: off, 1: on	Status parameter	Subway ODU j parameter, 1≤j≤16	
18624 +(j-1)	R	ODU j error status	0: normal, 1: with error	Error parameter	Subway ODU j parameter, 1≤j≤16	

Table 5: Data and address distribution of the analog values of hot-water and floor-heating Range: Word 28000~Word 34374								
Address	Access Type	Data Meaning	Range	Accuracy	Unit	Data Type	Remarks	Notices
28000 +25*(n-1)	R	Hot water temperature	Transmission value =actual value+100, actual value range: -30~100	1	°C	UINT16	Data of IDU n, 1≤n≤255	
28001 +25*(n-1)	R	Wired controller displays water temperature value of water tank	Transmission value =actual value+100, actual value range: -30~100	1	°C	UINT16		
28002 +25*(n-1)	W/R	Hot water operation mode	Transmission value =actual value, actual value: 0: Invalid; 1: Standard hot water; 2: Preset hot water; 3: Hot water at night	/	/	UINT16		
28003 +25*(n-1)	R	Hot water volume of water tank	Transmission value =actual value, actual value: 1: Invalid; 2: 1/5 capacity; 3: 2/5 capacity; 4: 3/5 capacity; 5: 4/5 capacity; 6: 5/5 capacity;	/	/	UINT16		
28004 +25*(n-1)	W/R	High temperature sterilization cycle of water tank	Transmission value =actual value, actual value range: 0~60	/	/	UINT16		
28005 +25*(n-1)	W/R	High temperature sterilization time of water tank	Lower byte: minute (0~60); Higher byte: hour (0~23);	/	/	UINT16		

28006 +25*(n-1)	R	Configuration of hydro box	Transmission value =actual value, actual value: 0: Invalid; 1: Gree water tank; 2: Floor heating; 3: Gree water tank + floor heating; 4: Gree water tank + solar power; 5: 3 in 1	/	/	UINT16		
28007 +25*(n-1)	W/R	Hot water preset time	Lower byte: minute (0~60); Higher byte: hour (0~23);	/	/	UINT16		
28008 +25*(n-1)	W/R	Hot water temperature setting	Transmission value =actual value*10, actual value range: 35~55	1	°C	UINT16		
28009 +25*(n-1)	W/R	Intelligent daytime hot water insulation setting temperature of water tank	Transmission value =actual value*10, actual value range: 35~50	1	°C	UINT16		
28010 +25*(n-1)	W/R	High temperature sterilization setting temperature of water tank	Transmission value =actual value*10, actual value range: 65~70	1	°C	UINT16		
28011 +25*(n-1)	W/R	Outlet water setting temperature of floor heating	Transmission value =actual value*10, actual value range: 25~45	1	°C	UINT16		

Table 6: Data and address distribution of the Switching values of hot-water and floor-heating						
Range: Bit 37608~Bit 49847						
Address	Access Type	Data Meaning	Range	Parameter type	Remarks	Notices
37608 +48*(n-1)	W/R	Hot-water on/off	1: on, 0: off	Status parameter	Data of IDU n, 1≤n≤255	
37609 +48*(n-1)	W/R	Floor-heating on/off	1: on, 0: off	Status parameter		
37610 +48*(n-1)	R	Hot-water heating/insulation status	1: heating; 0: insulation	Status parameter		
37611 +48*(n-1)	R	Floor-heating heating/insulation status	1: heating; 0: insulation	Status parameter		
37612 +48*(n-1)	W/R	Rapid hot-water function	1: rapid; 0: normal	Status parameter		
37613 +48*(n-1)	R	Icon of high temperature sterilization	1: normal sterilization; 0: without	Status parameter		
37614 +48*(n-1)	W/R	Auto setting of hot water temperature	1: auto; 0: without	Status parameter		
37615 +48*(n-1)	W/R	Sunflower function	1: on, 0: off	Status parameter		
37616 +48*(n-1)	W/R	Hot-water and floor-heating in priority under the same hydro box	1: floor-heating; 0: Hot-water	Status parameter		
37617 +48*(n-1)	R	Cycle pump operation status	1: on, 0: off	Status parameter		
37618 +48*(n-1)	R	Startup status of hot water auxiliary electric heater	1: on, 0: off	Status parameter		
37619 +48*(n-1)	R	Startup prohibitive icon of hot water auxiliary electric heater	1: prohibitive; 0: allowable	Status parameter		
					Reserved	
37623 +48*(n-1)	W/R	Remote lock of hot water function	1: lock; 0: no lock	Status parameter		
37624 +48*(n-1)	W/R	Rapid floor heating function	1: rapid; 0: normal	Status parameter		
37625 +48*(n-1)	R	Startup status of floor heating auxiliary electric heater	1: on; 0: off	Status parameter		
37626 +48*(n-1)	W/R	Floor-heating absence function	1: absence; 0. no absence	Status parameter		
37627 +48*(n-1)	R	If floor heating shunt valve 1 is open	1: open; 0: close	Status parameter		

37628 +48*(n-1)	R	If floor heating shunt valve 2 is open	1: open; 0: close	Status parameter		
37629 +48*(n-1)	R	If floor heating shunt valve 3 is open	1: open; 0: close	Status parameter		
37630 +48*(n-1)	R	If floor heating shunt valve 4 is open	1: open; 0: close	Status parameter		
37631 +48*(n-1)	R	If floor heating shunt valve 5 is open	1: open; 0: close	Status parameter		
37632 +48*(n-1)	R	If floor heating shunt valve 6 is open	1: open; 0: close	Status parameter		
37633 +48*(n-1)	R	Unit error	1: error; 0: normal	Error parameter		
37634 +48*(n-1)	W/R	High temperature sterilization setting of water tank	1: set; 0: not set	Status parameter		
					Reserved	
37636 +48*(n-1)	W/R	Auto setting of hydro box floor-heating water temperature	1: auto; 0: without	Status parameter		
					Reserved	
37638 +48*(n-1)	W/R	Remote lock of hydro box floor-heating function	1: lock; 0: no lock	Status parameter		



## 4.3.2 Energy recovery ventilation system

Table 7: Data and address distribution of the analog values								
Range: Word 9000~Word 26849								
Address	Access Type	Data Meaning	Range	Acc uracy	Unit	Data Type	Remarks	Notices
9000 +70*(n-1)	W/R	Operation mode	<b>【Setting】</b> : Transmission value =actual value, actual value: 0:invalid; 1:cooling; 2:dehumidifying; 3:fan;4: heating; 5:auto; 6: floor heating; 7: quick heating; 8: heat supply; <b>【Read】</b> : 01: cooling; 02:dehumidifying; 03:fan; 04: heating; 05:auto cooling; 06:auto heating; 07:floorheating; 08:quick heating; 09:heat supply; 0A: clothes drying; 0B: air discharge; 0C: auto dehumidifying;	/	/	UINT16	Data of IDU n, 1≤n≤255	
9001 +70*(n-1)	R	Return air and air inlet temperature	Transmission value =actual value+100, actual value range: 70~238	1	°C	UINT16		
9002 +70*(n-1)	R	Fresh air outlet temperature sensor	Transmission value =actual value+100, actual value range: 70~238	1	°C	UINT16		
9003 +70*(n-1)	R	Fresh air inlet temperature sensor	Transmission value =actual value+100, actual value range: 70~238	1	°C	UINT16		
9004 +70*(n-1)	R	Indoor relative humidity	Transmission value =actual value+100, actual value range: 120~190	1	%	UINT16		

9005 +70*(n-1)	R	Pollution degree of roughing efficiency filter	Transmission value =actual value+100, actual value range: 100~200	1	%	UINT16		
9006 +70*(n-1)	R	Pollution degree of high efficiency filter	Transmission value =actual value+100, actual value range: 100~200	1	%	UINT16		
9007 +70*(n-1)	R	Indoor air box 1: temperature sensor	Transmission value =actual value+100, actual value range: 70~238	1	°C	UINT16		
9008 +70*(n-1)	R	Indoor air box 2: temperature sensor	Transmission value =actual value+100, actual value range: 70~238	1	°C	UINT16		
9009 +70*(n-1)	R	Indoor air box 3: temperature sensor	Transmission value =actual value+100, actual value range: 70~238	1	°C	UINT16		
9010 +70*(n-1)	R	Indoor air box 4: temperature sensor	Transmission value =actual value+100, actual value range: 70~238	1	°C	UINT16		
9011 +70*(n-1)	R	Indoor air box 5: temperature sensor	Transmission value =actual value+100, actual value range: 70~238	1	°C	UINT16		
9012 +70*(n-1)	R	Indoor air box 1: humidity sensor	Transmission value =actual value+100, actual value range: 120~190	1	%	UINT16		
9013 +70*(n-1)	R	Indoor air box 2: humidity sensor	Transmission value =actual value+100, actual value range: 120~190	1	%	UINT16		
9014 +70*(n-1)	R	Indoor air box 3: humidity sensor	Transmission value =actual value+100, actual value range: 120~190	1	%	UINT16		
9015 +70*(n-1)	R	Indoor air box 4: humidity sensor	Transmission value =actual value+100, actual value range: 120~190	1	%	UINT16		

9016 +70*(n-1)	R	Indoor air box 5: humidity sensor	Transmission value =actual value+100, actual value range: 120~190	1	%	UINT16		
9017 +70*(n-1)	R	Outdoor relative humidity	Transmission value =actual value+100, actual value range: 120~190	/	%	UINT16		
9018 +70*(n-1)	R	Valid mode of IDU	Transmission value =actual value, actual value: 1: Valid mode; 0: Invalid mode; 0x00: Invalid; 0x01: Valid operation; 0x02: Valid linkage; 0x04: Valid automation;	/	/	UINT16		
9019 +70*(n-1)	W/R	Control mode	Transmission value =actual value, actual value: 0: Invalid; 1: Operation; 2: Linkage; 3: Auto; others: reserved	/	/	UINT16		

9020 +70*(n-1)	W/R	Fan speed	Transmission value =actual value, 【Setting】 : 0: invalid; 1: auto fan speed; 2: low fan speed; 3: Medium low fan speed; 4: Medium fan speed; 5: Medium high fan speed; 6: High fan speed; 【Read】 : 0: Invalid data; 1: The fan stops; 2: Ultra-low speed; 3: Low speed; 4: Medium and low speed; 5: Medium speed; 6: Medium and high speed; 7: High speed 8: Ultra-high speed; 9: Quiet speed R1; 10: Quiet speed R2; 11: Quiet speed R3	/	/	UINT16		
9021 +70*(n-1)	R	Pollution degree of outdoor air	Transmission value =actual value, actual value: 0: Invalid; 1: Excellent; 2: Good; 3: Mild pollution; 4: Medium pollution; 5: Severe pollution; 6: Serious pollution	/	/	UINT16		
9022 +70*(n-1)	R	Indoor air box 1: Air quality grade	Transmission value =actual value, actual value: 0: Invalid; 1: Excellent; 2: Good; 3: Mild pollution; 4: Medium pollution; 5: Severe pollution; 6: Serious pollution	/	/	UINT16		

9023 +70*(n-1)	R	Indoor air box 2: Air quality grade	Transmission value =actual value, actual value: 0: Invalid; 1: Excellent; 2: Good; 3: Mild pollution; 4: Medium pollution; 5: Severe pollution; 6: Serious pollution	/	/	UINT16		
9024 +70*(n-1)	R	Indoor air box 3: Air quality grade	Transmission value =actual value, actual value: 0: Invalid; 1: Excellent; 2: Good; 3: Mild pollution; 4: Medium pollution; 5: Severe pollution; 6: Serious pollution	/	/	UINT16		
9025 +70*(n-1)	R	Indoor air box 4: Air quality grade	Transmission value =actual value, actual value: 0: Invalid; 1: Excellent; 2: Good; 3: Mild pollution; 4: Medium pollution; 5: Severe pollution; 6: Serious pollution	/	/	UINT16		
9026 +70*(n-1)	R	Indoor air box 5: Air quality grade	Transmission value =actual value, actual value: 0: Invalid; 1: Excellent; 2: Good; 3: Mild pollution; 4: Medium pollution; 5: Severe pollution; 6: Serious pollution	/	/	UINT16		
9027 +70*(n-1)	R	Working status of indoor air box	Range: 0~00011111 0: Not working; 1: Working;	/	/	UINT16		bit n means air box No.n

9028 +70*(n-1)	W/R	LED switch status of indoor air box	Range: 0~00011111 0: Turn on; 1: Turn off;	/	/	UINT16		bit n means air box No.n
9029 +70*(n-1)	W/R	Indoor main air box setting	0: No main box; 1: Set it as the main box	/	/	UINT16		★(29)
9030 +70*(n-1)	W/R	PM2.5 sensor switch status	Range: 0~00011111 0: Off; 1: On;	/	/	UINT16		bit n means air box No.n
9031 +70*(n-1)	W/R	Operation mode	Transmission value =actual value, <b>【Setting】</b> : 0: Invalid data; 1: Total heat exchange mode; 2: Bypass mode; 3: Exhaust fan mode; 4: Low temperature mode;  <b>【Read】</b> : 0: Invalid data; 1: Total heat mode; 2: Bypass mode; 3: Exhaust fan mode; 4: Low temperature mode; 5: Inner circulation 1; 6: Inner circulation 2	/	/	UINT16		
9032 +70*(n-1)	R	Operation speed of exhaust fan	Transmission value =actual value, actual value: 0: Invalid data; 1: The fan stops; 2: Ultra-low speed; 3: Low speed; 4: Medium and low speed; 5: Medium speed; 6: Medium and high speed; 7: High speed; 8: Ultra-high speed; 9: Quiet speed R1; 10: Quiet speed R2; 11: Quiet speed R3	/	/	UINT16		

9033 +70*(n-1)	W/R	Positive and negative pressure setting	Transmission value =actual value, actual value: 0: Invalid data; 1: Normal fan speed; 2: Positive pressure mode; 3: Negative pressure mode	/	/	UINT16		
9034 +70*(n-1)	W/R	Positive pressure setting	Transmission value =actual value, actual value: 0: Invalid data; 1: Speed 0; 2: Speed 1; 3: Speed 2; 4: Speed 3; 5: Speed 4; 6: Speed 5;	/	/	UINT16		
9035 +70*(n-1)	W/R	Static pressure setting	Transmission value =actual value, actual value: 0: Invalid data; 1: 0Pa; 2: 25Pa; 3: 50Pa; 4: 75Pa; 5: 100Pa	/	/	UINT16		
9036 +70*(n-1)	R	Indoor air box 1: PM2.5 value	Transmission value =actual value	1	$\mu$ g/m <sup>3</sup>	UINT16		
9037 +70*(n-1)	R	Indoor air box 2: PM2.5 value	Transmission value =actual value	1	$\mu$ g/m <sup>3</sup>	UINT16		
9038 +70*(n-1)	R	Indoor air box 3: PM2.5 value	Transmission value =actual value	1	$\mu$ g/m <sup>3</sup>	UINT16		
9039 +70*(n-1)	R	Indoor air box 4: PM2.5 value	Transmission value =actual value	1	$\mu$ g/m <sup>3</sup>	UINT16		
9040 +70*(n-1)	R	Indoor air box 5: PM2.5 value	Transmission value =actual value	1	$\mu$ g/m <sup>3</sup>	UINT16		
9041 +70*(n-1)	R	Indoor air box 1: CO2 value	Transmission value =actual value	1	ppm	UINT16		
9042 +70*(n-1)	R	Indoor air box 2: CO2 value	Transmission value =actual value	1	ppm	UINT16		
9043 +70*(n-1)	R	Indoor air box 3: CO2 value	Transmission value =actual value	1	ppm	UINT16		
9044 +70*(n-1)	R	Indoor air box 4: CO2 value	Transmission value =actual value	1	ppm	UINT16		

9045 +70*(n-1)	R	Indoor air box 5: CO2 value	Transmission value =actual value	1	ppm	UINT16		
9046 +70*(n-1)	W/R	Temperature setting	Transmission value =actual value×10, actual value: 16.0~30.0;	1	°C	UINT16		
9047 +70*(n-1)	W/R	Indoor relative humidity setting	Transmission value =actual value; 0:invalid data, actual value range: 1~100	1	%	UINT16		
9048 +70*(n-1)	W/R	Max.outdoor relative humidity setting	Transmission value =actual value; 0:invalid data, actual value range: 1~100	1	%	UINT16		
9049 +70*(n-1)	W/R	Target value of indoor air quality grade	Transmission value =actual value, actual value: 0: Invalid; 1: Excellent; 2: Good	/	/	UINT16		
9050 +70*(n-1)	W/R	Outdoor air pollution grade	Transmission value =actual value, actual value: 0: Invalid; 1: Excellent; 2: Good; 3: Mild pollution; 4: Medium pollution; 5: Severe pollution; 6: Serious pollution	/	/	UINT16		
9051 +70*(n-1)	W/R	Setting for indoor air box switch	Range: 0~00011111 0: Not working; 1: Working;	/	/	UINT16		bit n means air box No.n



Table 8: Data and address distribution of the Switching values						
Range: Bit 19240~Bit 35559						
Address	Access Type	Data Meaning	Range	Parameter type	Remarks	Notices
19240 +64*(n-1)	R	IDU error	0: no, 1: yes	Error parameter	Data of IDU n, 1≤n≤255	
19241 +64*(n-1)	R	Errors of several main wired controllers	0: no, 1: yes	Error parameter		
19242 +64*(n-1)	R	Conflict of IDU project No.	0: no, 1: yes	Error parameter		
19243 +64*(n-1)	R	Main communication error of IDU	0: no, 1: yes	Error parameter		
19244 +64*(n-1)	R	Main communication error of IDU and ODU	0: no, 1: yes	Error parameter		
19245 +64*(n-1)	R	(Airflow volume) dial code setting error	0: no, 1: yes	Error parameter		
19246 +64*(n-1)	R	Fresh air outlet temperature sensor error	0: no, 1: yes	Error parameter		
19247 +64*(n-1)	R	air inlet temperature sensor error	0: no, 1: yes	Error parameter		
19248 +64*(n-1)	R	Indoor humidity sensor error	0: no, 1: yes	Error parameter		
19249 +64*(n-1)	R	Anti-freezing protection	0: no, 1: yes	Error parameter		
19250 +64*(n-1)	R	Communication error between IDU and indoor box 1	0: no, 1: yes	Error parameter		
19251 +64*(n-1)	R	Communication error between IDU and indoor box 2	0: no, 1: yes	Error parameter		
19252 +64*(n-1)	R	Communication error between IDU and indoor box 3	0: no, 1: yes	Error parameter		
19253 +64*(n-1)	R	Communication error between IDU and indoor box 4	0: no, 1: yes	Error parameter		
19254 +64*(n-1)	R	Communication error between IDU and indoor box 5	0: no, 1: yes	Error parameter		
19255 +64*(n-1)	R	Indoor fan protection	0: no, 1: yes	Error parameter		
19256 +64*(n-1)	R	Return air and air inlet temperature sensor error	0: no, 1: yes	Error parameter		

19257 +64*(n-1)	R	IFD error	0: no, 1: yes	Error parameter		
19258 +64*(n-1)	R	Return air and air outlet temperature sensor error	0: no, 1: yes	Error parameter		
19259 +64*(n-1)	R	Communication error between IDU and air box	0: no, 1: yes	Error parameter		
19260 +64*(n-1)	R	Indoor air box 1: main error	0: no, 1: yes	Error parameter		
19261 +64*(n-1)	R	Indoor air box 2: main error	0: no, 1: yes	Error parameter		
19262 +64*(n-1)	R	Indoor air box 3: main error	0: no, 1: yes	Error parameter		
19263 +64*(n-1)	R	Indoor air box 4: main error	0: no, 1: yes	Error parameter		
19264 +64*(n-1)	R	Indoor air box 5: main error	0: no, 1: yes	Error parameter		
19265 +64*(n-1)	W/R	Power on/Power off	0: power off; 1: power on	Status parameter		
19266 +64*(n-1)	W/R	Turbo fan speed function setting	0: off, 1: on	Status parameter		
19267 +64*(n-1)	W/R	Long distance shielding control mode function	0: no shielding; 1: shielded	Status parameter		
19268 +64*(n-1)	W/R	Long distance shielding ON/OFF function	0: no shielding; 1: shielded	Status parameter		
19269 +64*(n-1)	W/R	Long distance lock function	0: no shielding; 1: shielded	Status parameter		
19270 +64*(n-1)	W/R	Shielding ON	0: no shielding; 1: shielded	Status parameter		
19271 +64*(n-1)	W/R	Shielding OFF	0: no shielding; 1: shielded	Status parameter		
19272 +64*(n-1)	W/R	Shielding timer	0: no shielding; 1: shielded	Status parameter		
19273 +64*(n-1)	W/R	Auxiliary electrical heater	0: off, 1: on	Status parameter		
19274 +64*(n-1)	W/R	Health function	0: off, 1: on	Status parameter		
19275 +64*(n-1)	W/R	Humidification function	0: off, 1: on	Status parameter		
19276 +64*(n-1)	R	Electrostatic dedusting	0: off, 1: on	Status parameter		
19277 +64*(n-1)	R	Filter dirty cleaning alarm	0: no 1: filter cleaning	Status parameter		
19278 +64*(n-1)	R	Filter dirty replacement alarm	0: no 1: replacement alarm	Status parameter		

19279 +64*(n-1)	R	IFD filter screen cleaning alarm	0: no 1: filter cleaning	Status parameter		
19280 +64*(n-1)	R	High efficiency filter screen replacement alarm	0: no 1: replacement alarm	Status parameter		
19281 +64*(n-1)	W/R	Energy saving mode	0: off, 1: on	Status parameter		
19282 +64*(n-1)	W/R	Cancel IFD filter cleaning alarm	0: no 1: command the IDU to clear	Status parameter		
19283 +64*(n-1)	W/R	Cancel high efficiency filter screen replacement alarm	0: no 1: command the IDU to clear	Status parameter		
19284 +64*(n-1)	W/R	Cancel filter cleaning alarm	0: no 1: command the IDU to clear	Status parameter		
19285 +64*(n-1)	W/R	Cancel filter replacement alarm	0: no 1: command the IDU to clear	Status parameter		

## 5. Precautions before the Use of Gateway

1. Make sure the power supply is consistent with specifications; otherwise, Modbus gateway will not work or may even be damaged.
2. Make sure the DIP switch is correctly set; otherwise, communication failure will occur.
3. Make sure the communication lines are connected to correct interfaces; otherwise, communication failure will occur.
4. Strengthen the connection of communication lines with soldering tin. Use insulating tape to protect the lines from oxidization and short circuit.
5. Working condition for the Modbus gateway: ①Temperature:  $-20^{\circ}\text{C} \sim +60^{\circ}\text{C}$ ; ②Humidity $\leq 85\%$ ; ③Installed indoors, inside an electric control cabinet, avoid direct sunlight, rain and snow.
6. Warning: If the working condition cannot meet the above requirements, Modbus gateway may fail to function normally.
7. In installation process, the twisted-pair of communication cord used shall meet Gree's requirements (refer to the specification of Modbus Gateway (Pro)).The length shall be decided according to the engineering demand, parts of circuit user shall prepare the 4-core(or 2-core) V twisted-pair themselves.
8. Gree reserves the right to upgrade the product without prior notice.

## Annex A

(Regulatory Annex)

### Calculation Method of Cyclic Redundancy Code (CRC)

#### A.1 CRC Calculation Method

The calculation method of CRC is: First, preset a 16-bit register to 1 for all; then, process each piece of 8-bit data step by step. When calculating CRC, XOR the 8-bit data with register data and then right shift the result towards the low bit by one bit and fill 0 into the high bit. Then check the low bit, if it is 1, XOR register contents with the preset number; if it is 0, stop the XOR operation. Repeat this process for 8 times. After right shift is conducted for 8 times, XOR the next piece of 8-bit data with the current register contents and repeat the process as instructed above for 8 times. When every piece of data has been process, the last register is the result of CRC.

#### A.2 How to Calculate CRC

- 1) Preset a 16-bit register to hexadecimal characters FFFF (i.e. 1 for all). Name this register as CRC register.
- 2) XOR the first piece of 8-bit data with the low bit of 16-bit CRC register, then place the result into CRC register.
- 3) Right shift register contents by one bit (towards the low bit), then fill 0 into the high bit. Before shifting, check the low bit.
- 4) If the low bit is 0, repeat step 3 (right shift again);  
If the low bit is 1, then XOR CRC register with multinomial A001 (1010 0000 0000 0001).
- 5) Repeat step 3 and step 4 until right shift is conducted for 8 times, so that the entire piece of 8-bit data has been processed.
- 6) Repeat from step 2 to step 5 to process the next piece of 8-bit data.
- 7) The final CRC register is the result of CRC.

## A.3 CRC Example (For Reference Only)

Parameter: Data (data block starting address), Data Size (data block byte count) feedback: CRC calculation result

```
uint16 CRC_Calculate(uint8 *data, uint16 dataSize)
{
    uint8 i;
    uint8 temp;
    uint16 j;
    uint16 CRCCode;
    CRCCode=0xffff;
    for(j=0;j<dataSize;j++){
        CRCCode = CRCCode^data[j];
        for( i = 0; i < 8; i++){
            temp = CRCCode & 0x0001;
            CRCCode = (CRCCode >> 1);
            if(temp ==1){
                CRCCode = (CRCCode^0xA001);// 0xA001 preset polynomial, the constant value.
            }
        }
    }
    return CRCCode;
}
```

## References

1. Modbus Protocol
2. Modbus Gateway(Pro) Instruction Manual