



CWS and CWE

Cassette Fan Coil Unit

TECHNICAL LEAFLET

CWS

Cassette Fan Coil Unit with Asynchronous Motor

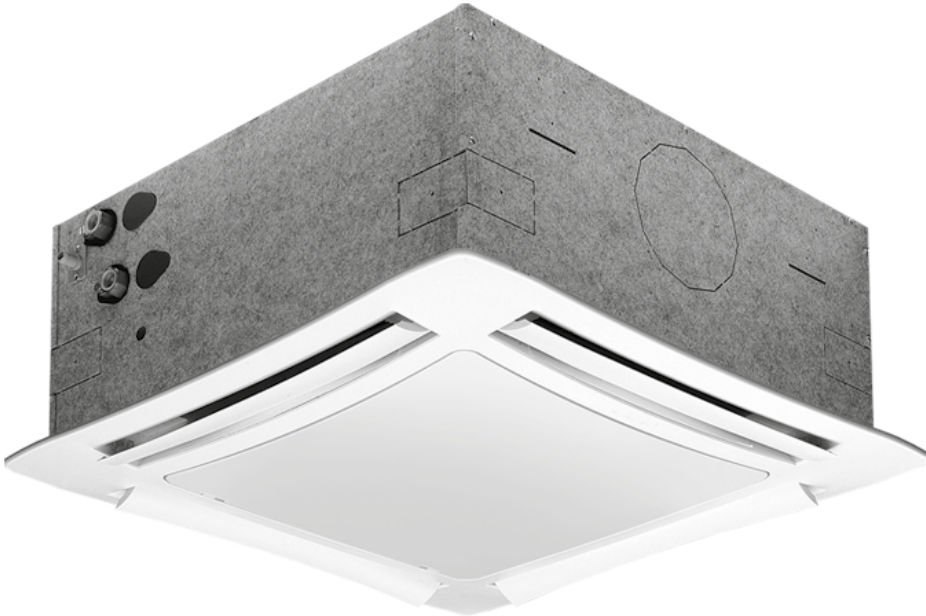

Innovating and beautiful design, **seven different sizes**, high control flexibility, easy maintenance: the **CWS chilled water Cassette** is the result of an extended technical and design development aimed at achieving the highest level in terms of performance, silent operation and control possibilities.

The air diffuser has a highly attractive aesthetical appearance, very innovative, and is also able to offer the best air distribution performance thanks to in-depth computer studies and laboratory tests.

The 4 smaller sizes are designed to fit into **600 x 600 mm false ceiling** standard modules. The bigger sizes have a **dimension of 800 x 800 mm** which allows the best outcome in terms of quietness and of price/performance ratio for these high capacity models.



In addition to temperature and speed standard controls, **automatic** speed selection is also available.

More than one unit can be connected to a single control, and the unit control panel can be installed in a remote position that **facilitates** the maintenance operation.

All the CWS units can be supplied in **MB version**. This version allows a wide range of controls, including the infra-red remote control, which can manage one single unit or several units by using the **Modbus RTU - RS 485** communication protocol.

The units can be connected to the most common automatic building management systems.



Air diffusers into the Trane versions

Intake grid, frame and adjustable air distribution louvers on each side, made from ABS.

DIFF600 / DIFF800 version

white ABS, RAL 9003



DIFF600 / DIFF800 version

intake grid, frame and louvers in a colour of choice



DIFFMD600 / DIFFMD800 version

metal diffuser painted in RAL 9003 white colour to perfectly fit into the false ceiling standard modules without overlapping parts



Casing: made of galvanized steel with internal thermal insulation with polyolefin (PO) foam (class M1) and external anti-condensate lining.

Control panel: made of an external metallic box with control electronic board and easily accessible terminal board.

Fan assembly: the fan assembly, which is mounted on anti-vibrating supports, is extremely silent.

The radial fan has been designed to optimise performance, using wing profile blades with a shape that reduces turbulence, increasing efficiency and reducing noise.

The single air inlet radial fan is connected to a 6 speed electric motor with **single phase 230 V / 50 Hz** supply, class B insulation and integrated Klixon thermal contact for motor protection.

The units are supplied with 3 standard speeds connected and it is possible to change them on the construction site if necessary.

Coil: made of copper tubes with bonded aluminium fins for maximum transfer contact. The coils have 1, 2 or 3 rows for 2 pipe models and 2+1 rows for 4 pipe models (the heating row is on the inside part of the coil).

For 4 pipe systems two versions are available:

- **CWS 04-4P, CWS 14-4P, CWS 24-4P, CWS 34-4P, CWS 44-4P, CWS 54-4P, CWS 64-4P** supply an higher heating emission;
- **CWS 26-4P, CWS 36-4P, CWS 56-4P, CWS 66-4P** supply an higher cooling emission.

The coil is not suitable for use in corrosive atmosphere or in environments where aluminium may be subject to corrosion.

Condensate collection tray: high density ABS polystyrene foam condensate tray, shaped in order to optimize the air diffusion, fire retardant rating B1 to DIN 4102.

Air filter: synthetic washable filter, easily removable.

Condensate pump: float switch centrifugal pump with 650 mm of maximum head, built into the unit and wired to the control panel on the outside of the casing.

Valve set: two or three way valves for ON/OFF operation, with pipe mounting kit and thermostatic actuator.

CWS 02-04 / CWS 12-14 / CWS 22-24-26 / CWS 32-34-36
(Version 600 x 600)

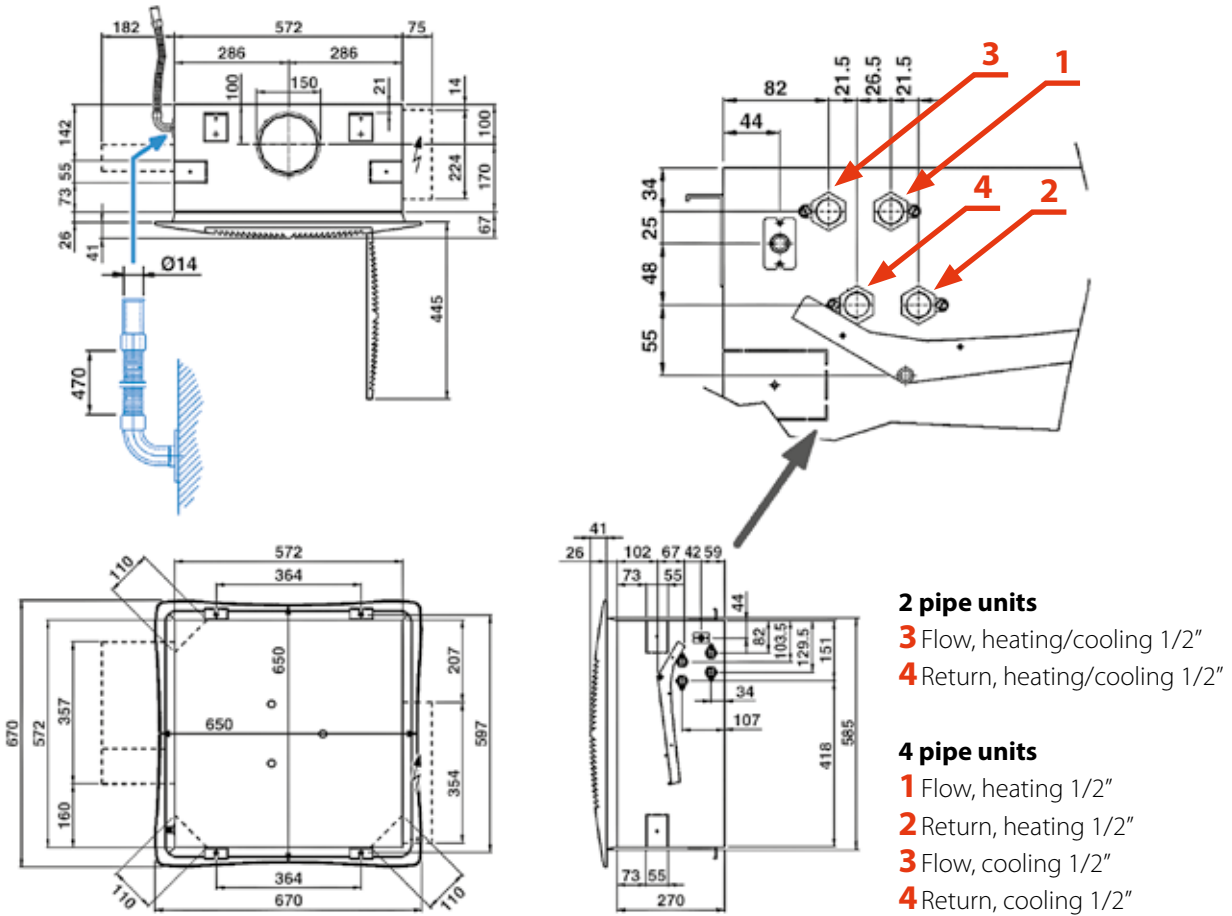

Metal diffuser

MD-600

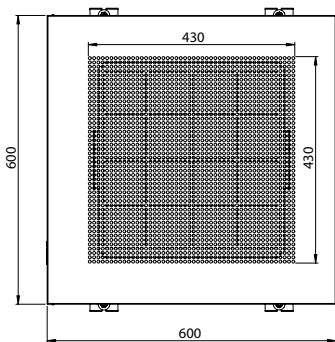

MD-800

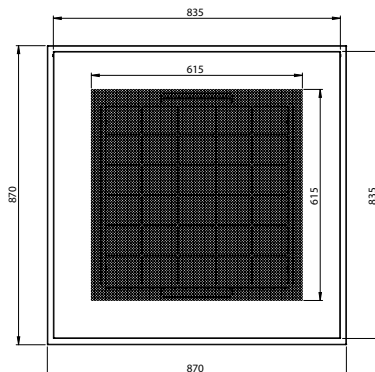

Model	Code
MD-600	9079420
MD-800	9079417

Model	Unit		Diffuser		Packed unit dimensions (mm)			
	Weight packed unit kg	Weight unpacked unit kg	Weight packed unit kg	Weight unpacked unit kg	A	B	C	D
CWS 02 - 12	21	18	3,5	2,5	790	350	750	150
CWS 04 - 14	22,5	19,5						
CWS 22 - 24 - 26	22	19						
CWS 32 - 34 - 36								

CWS 42-44 / CWS 52-54-56 / CWS 62-64-66
(Version 800 x 800)

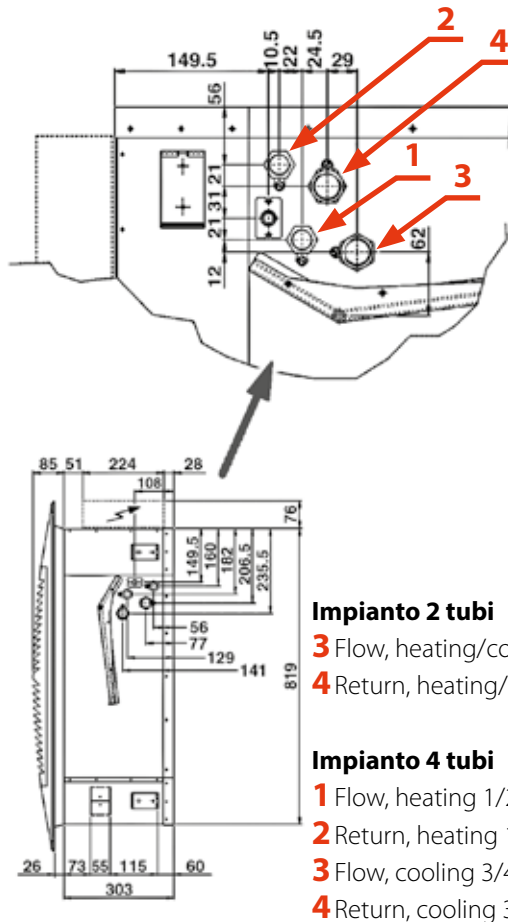
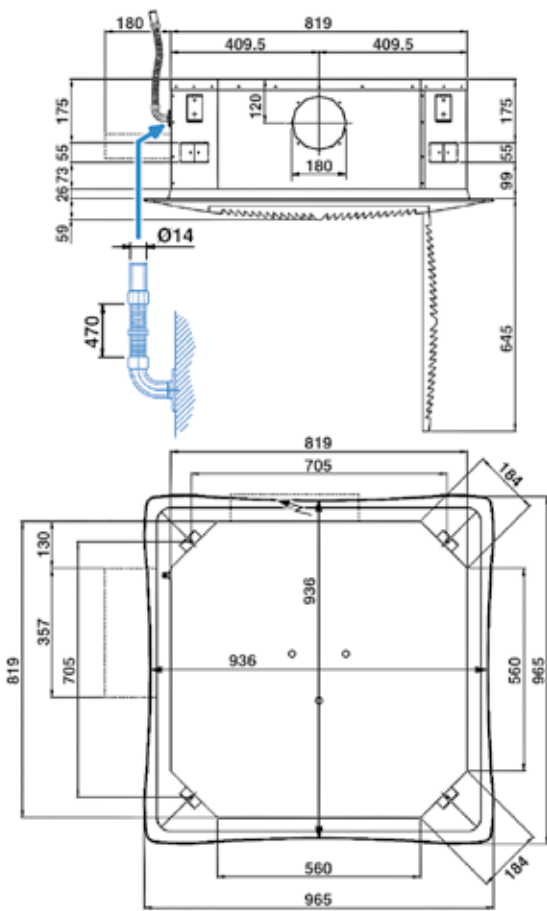

Impianto 2 tubi

- 3** Flow, heating/cooling 3/4"
- 4** Return, heating/cooling 3/4"

Impianto 4 tubi

- 1** Flow, heating 1/2"
- 2** Return, heating 1/2"
- 3** Flow, cooling 3/4"
- 4** Return, cooling 3/4"

Unit

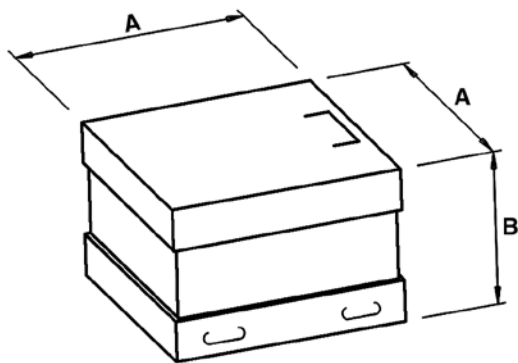

Diffuser

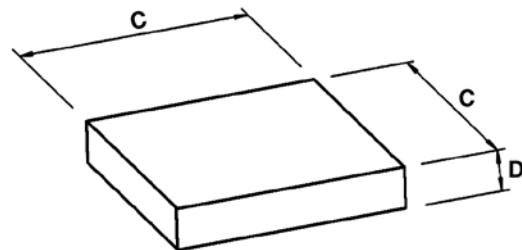

Model	Unit		Diffuser		Packed unit dimensions (mm)			
	Weight packed unit kg	Weight unpacked unit kg	Weight packed unit kg	Weight unpacked unit kg	A	B	C	D
CWS 42	40	35	7	5,5	1050	400	1000	200
CWS 44	44	39						
CWS 52 - 54 - 56								
CWS 62 - 64 - 66								

CWS

2 pipe units. The following standard rating conditions are used:

COOLING (summer mode)

Entering air temperature: +27°C d.b. +19°C w.b.
Water temperature: +7°C E.W.T. +12°C L.W.T.

HEATING (winter mode)

Entering air temperature: +20°C
Water temperature: +45°C E.W.T. +40°C L.W.T.

Model		CWS 02-2P			CWS 12-2P			CWS 22-2P			CWS 32-2P		
		1	2	3	1	2	3	1	2	3	1	2	3
Speed													
Air flow	m ³ /h	310	420	610	310	420	520	320	500	710	430	610	880
Cooling total emission(E)	kW	1,25	1,60	1,92	1,82	2,31	2,64	2,23	3,30	4,26	2,91	3,82	4,93
Cooling sensible emission (E)	kW	0,99	1,29	1,58	1,33	1,72	2,00	1,55	2,35	3,11	2,05	2,75	3,65
Heating (E)	kW	1,38	1,80	2,24	1,85	2,42	2,80	2,12	3,28	4,37	2,85	3,85	5,15
Heating - Water 70-60°C	kW	2,80	3,66	4,56	4,19	4,91	5,68	4,83	6,96	9,25	6,10	8,25	10,63
Dp Cooling (E)	kPa	4,5	7,0	10,0	4,9	7,6	9,7	6,4	13,0	20,9	7,5	12,4	19,7
Dp Heating (E)	kPa	4,4	7,2	10,7	4,3	6,9	9,0	2,8	6,1	10,2	6,2	10,6	17,8
Sound power Lw (E)	dB(A)	33	40	49	33	40	45	33	45	53	41	49	59
Sound pressure Lp (*)	dB(A)	24	31	40	24	31	36	24	36	44	32	40	50
Fan (E)	W	25	32	57	25	32	44	25	44	68	32	57	90
	A	0,11	0,15	0,27	0,11	0,15	0,20	0,11	0,20	0,32	0,15	0,27	0,45
Water content	l	0,8	0,8	0,8	1,4	1,4	1,4	2,1	2,1	2,1	2,1	2,1	2,1
Dimensions	mm	575 x 575 x 275											

Model		CWS 42-2P			CWS 52-2P			CWS 62-2P		
		1	2	3	1	2	3	1	2	3
Speed										
Air flow	m ³ /h	630	820	1140	710	970	1500	710	1280	1820
Cooling total emission(E)	kW	4,18	4,86	6,08	5,27	6,72	9,39	5,27	8,36	10,93
Cooling sensible emission (E)	kW	3,00	3,53	4,51	3,42	4,42	6,36	3,67	6,00	8,08
Heating (E)	kW	4,27	5,03	6,50	4,92	6,40	9,23	5,12	8,55	11,72
Heating - Water 70-60°C	kW	8,61	10,16	13,14	10,25	13,43	19,76	10,25	17,26	23,68
Dp Cooling (E)	kPa	10,9	14,3	21,6	9,4	14,7	26,9	9,4	21,8	35,6
Dp Heating (E)	kPa	7,0	9,4	15,0	7,1	11,4	22,0	7,6	19,2	33,8
Sound power Lw (E)	dB(A)	33	40	48	34	40	53	34	48	58
Sound pressure Lp (*)	dB(A)	24	31	39	25	31	44	25	39	49
Fan (E)	W	33	48	77	42	63	120	42	95	170
	A	0,15	0,23	0,36	0,18	0,28	0,53	0,18	0,42	0,74
Water content	l	3,0	3,0	3,0	4,0	4,0	4,0	4,0	4,0	4,0
Dimensions	mm	820 x 820 x 303								

(E) = Eurovent certified performance.

(*) = The sound pressure levels are 9 dB(A) lower than the sound power levels and apply to the reverberant field of a 100 m³ room and a reverberation time of 0.5 sec.

4 pipe units. The following standard rating conditions are used:

COOLING (summer mode)

Entering air temperature: +27°C d.b. +19°C w.b.
Water temperature: +7°C E.W.T. +12°C L.W.T.

HEATING (winter mode)

Entering air temperature: +20°C
Water temperature: +65°C E.W.T. +55°C L.W.T.

Model		CWS 04-4P			CWS 14-4P			CWS 24-4P			CWS 26-4P			CWS 34-4P			CWS 36-4P		
		1	2	3	1	2	3	1	2	3	1	2	3	1	2	3	1	2	3
Speed																			
Air flow	m ³ /h	310	420	610	310	420	520	310	500	710	320	500	710	430	610	880	430	610	880
Cooling total emission (E)	kW	1,49	1,93	2,27	1,83	2,33	2,66	1,83	2,61	3,27	2,07	3,02	3,86	2,33	2,96	3,72	2,69	3,47	4,44
Cooling sensible emission (E)	kW	1,13	1,52	1,84	1,32	1,68	1,94	1,32	1,94	2,49	1,47	2,20	2,88	1,72	2,23	2,88	1,94	2,56	3,37
Dp Cooling (E)	kPa	6,0	10,0	13,5	4,6	6,9	8,8	4,6	8,8	13,4	4,0	7,0	10,5	7,2	11,2	17,0	6,0	9,0	14,0
Heating (E)	kW	1,72	2,23	2,66	2,13	2,66	3,04	2,13	3,04	3,86	1,73	2,71	2,91	2,61	3,33	4,19	2,14	2,66	3,29
Dp Riscaldamento (E)	kPa	5,2	8,3	11,4	4,6	6,8	8,7	4,6	8,7	13,3	2,6	4,6	6,7	6,4	9,9	15,0	3,9	5,7	8,4
Sound power Lw (E)	dB(A)	33	40	49	33	40	45	33	45	53	33	45	53	41	49	59	41	49	59
Sound pressure Lp (*)	dB(A)	24	31	40	24	31	36	24	36	44	24	36	44	32	40	50	32	40	50
Fan (E)	W	25	32	57	25	32	44	25	44	68	25	44	68	32	57	90	32	57	90
	A	0,11	0,15	0,27	0,11	0,15	0,20	0,11	0,20	0,32	0,11	0,20	0,32	0,15	0,27	0,45	0,15	0,27	0,45
Cooling water content	l	1,0	1,0	1,0	1,4	1,4	1,4	1,4	1,4	1,4	1,7	1,7	1,7	1,4	1,4	1,4	1,7	1,7	1,7
Heating water content	l	0,6	0,6	0,6	0,7	0,7	0,7	0,7	0,7	0,7	0,5	0,5	0,5	0,7	0,7	0,7	0,5	0,5	0,5
Dimensions	mm	575 x 575 x 275																	

Model		CWS 44-4P			CWS 54-4P			CWS 56-4P			CWS 64-4P			CWS 66-4P		
		1	2	3	1	2	3	1	2	3	1	2	3	1	2	3
Speed																
Air flow	m ³ /h	630	820	1140	710	970	1500	710	970	1500	710	1280	1820	710	1280	1820
Cooling total emission (E)	kW	4,11	4,98	6,26	4,48	5,60	7,59	4,95	6,27	8,65	4,48	6,84	8,72	4,95	7,75	9,69
Cooling sensible emission (E)	kW	2,93	3,60	4,61	3,21	4,09	5,71	3,49	4,49	6,37	3,21	5,09	6,67	3,49	5,64	7,26
Dp Cooling (E)	kPa	8,8	12,5	18,9	10,3	15,4	26,9	9,0	14,0	25,0	10,3	22,1	34,7	9,0	20,0	32,0
Heating (E)	kW	5,21	6,33	8,02	5,69	7,15	9,66	4,59	5,63	7,50	5,69	8,80	11,16	4,59	6,78	9,48
Dp Riscaldamento (E)	kPa	7,9	11,2	17,2	9,3	14,0	24,0	4,9	7,0	11,8	9,3	20,3	31,2	4,9	9,9	15,0
Sound power Lw (E)	dB(A)	33	40	48	34	40	53	34	40	53	34	48	58	34	48	58
Sound pressure Lp (*)	dB(A)	24	31	39	25	31	44	25	31	44	25	39	49	25	39	49
Fan (E)	W	33	48	77	42	63	120	42	63	120	42	95	170	42	95	170
	A	0,15	0,23	0,36	0,18	0,28	0,53	0,18	0,28	0,53	0,18	0,42	0,74	0,18	0,42	0,74
Cooling water content	l	3,0	3,0	3,0	3,0	3,0	3,0	3,6	3,6	3,6	3,0	3,0	3,0	3,6	3,6	3,6
Heating water content	l	1,4	1,4	1,4	1,4	1,4	1,4	1,1	1,1	1,1	1,4	1,4	1,4	1,1	1,1	1,1
Dimensions	mm	820 x 820 x 303														

(E) = Eurovent certified performance.

(*) = The sound pressure levels are 9 dB(A) lower than the sound power levels and apply to the reverberant field of a 100 m³ room and a reverberation time of 0.5 sec.

CWS-MX All the CWS units can be supplied in MB version. This version allows a wide range of controls, including the infra-red remote control, which can manage one single unit or several units by using the Modbus RTU - RS 485 communication protocol.



CWS-X The Cassette 2 pipe models are available with electric heater that is controlled in place of the heating coil valve. The electric heater is controlled in place of the hot water valve and not as integration to it. The electric heater is hermetically sealed and supplied inside the coil pipes and therefore can be only factory mounted. The electric heaters of the units are for single phase 230 V supply.

Model	Emission
CWS 12-2P-X	1500 W
CWS 22-2P-X / CWS 32-2P-X	2500 W
CWS 42-2P-X / CWS 52-2P-X CWS 62-2P-X	3000 W

Unit with remote electric board

On request the CWS cassettes are available with electric control panel reachable from below and with the electric board that can be placed in a remote position.

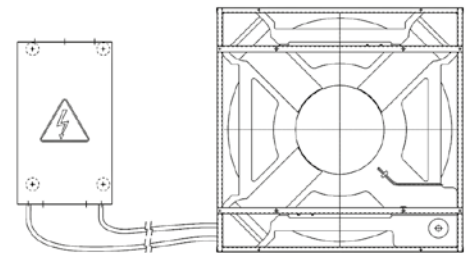

MCT The **MCT** version has been designed for all environments where false ceilings are not featured or cannot be constructed. The cover cabinet fits perfectly to the air intake and outlet diffuser, maintaining the appealing design that defines the SkyStar series. The water fittings can be turned to point upwards. The **MCT** series includes 7 models, with an installation height of up to 5 m, thanks to the highly flexible adjustment of the air distribution louvers. All the technical specifications described on the previous pages remain the same, while keeping in mind that the **MCT** series features one coil only (two pipe systems), there is no possibility of fresh air intake, there is no possibility of additional electric heater. The **MCT** version features a special casing delivered in separate packaging; this must only be fitted after having installed the SkyStar unit and completed the water and electrical connections.



3 way ON-OFF valves with micrometric lockshield valve

Valve set, 3 ways, ON-OFF, with thermoelectric actuator. The set includes connection pipes and holders.

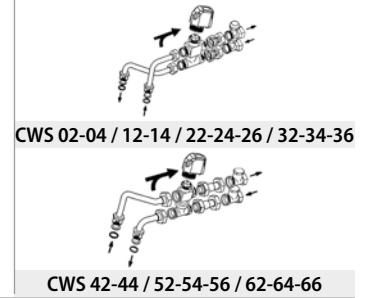

2 way ON-OFF valves with micrometric lockshield valve

Valve set, 2 ways, ON-OFF, with thermoelectric actuator. The set includes connection pipes and holders.

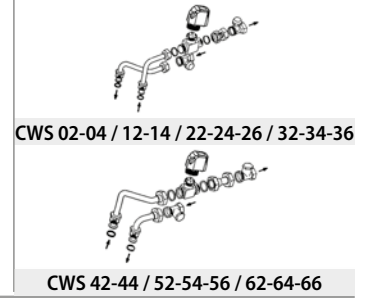

3 way ON-OFF valves with simplified kit

Valve set, 3 ways, ON-OFF, with thermoelectric actuator. The set includes connection pipes.

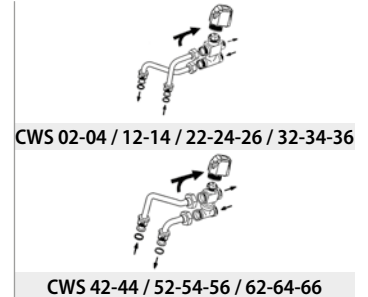

2 way ON-OFF valves with simplified kit

Valve set, 2 ways, ON-OFF, with thermoelectric actuator. The set includes connection pipes.

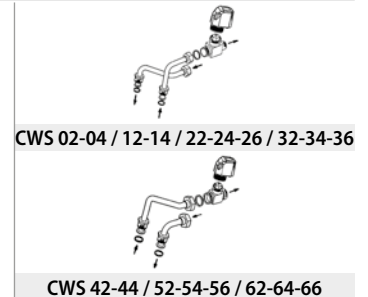

V20VSK Balancing valves independent from the system pressure (Oventrop)
(for main and additional coil)

V2DFSK Balancing valves independent from the system pressure (Danfoss)
(for main and additional coil)

CDA Air distribution connection

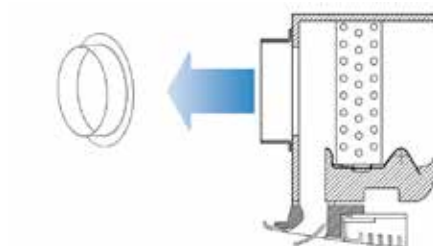

CAP Fresh air connection

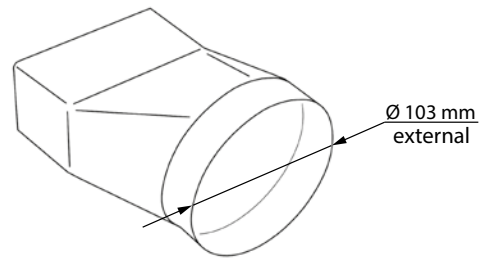

PRT Fresh air kit

This is used to introduce fresh air into the environment directly through the diffuser.

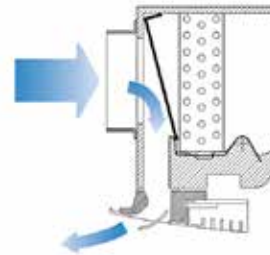

PM-SK Fitted condensate pump with higher pressure head

IAQ accessory

CWS / CWE Cassette can be equipped with the innovative plate type **electrostatic filter**, combining air treatment and purifying in a single product.

The electronic filter is **patented and certified** according to Standard UNI 11254 and EN 16890.

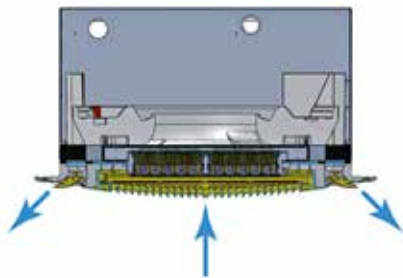

Dimensions

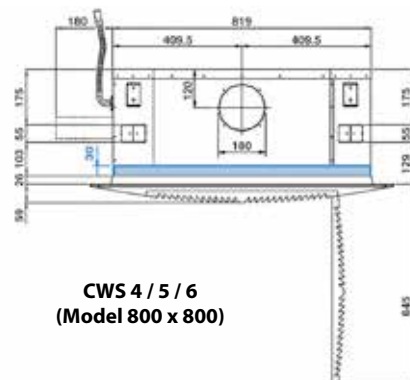
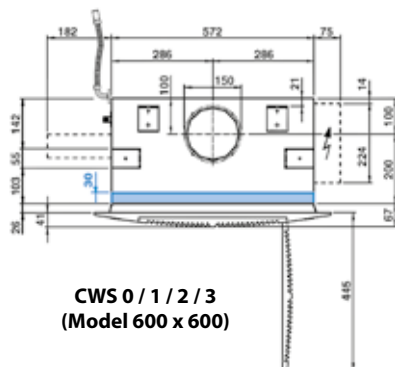

Electronic wall controls

CWS version	
M-3V	3 speed control
T-TMO	3 speed control with electronic thermostat and manual summer/winter switch
T-REM	3 speed control with electronic thermostat and centralized/manual summer/winter switch
T-AUTO	Automatic speed control with electronic thermostat and summer/winter switch (to be used with T-POWER-M or T-POWER-A only)
IR-MB2S	IR-MB2S wall control (to be used with T-POWER-M or T-POWER-A only)
T-POWER-M	T-POWER-A power unit for T-AUTO and IR-MB2S remote controls, fitted on the unit
T-POWER-A	T-POWER-A power unit for T-AUTO and IR-MB2S remote controls, not fitted on the unit

Electronic controls

CWS-MX version	
IR-MB2S	IR-MB2S wall control (to be used with CWS-MX version only)
RT03-REC-A	RT03-A infra-red remote control with receiver supplied with separate packaging (to be used with CWS-MX version only)
RT03-A	RT03-A infra-red remote control supplied with separate packaging (to be used with CWS-MX version only)
REC-A	Receiver for RT03-A infra-red remote control supplied with separate packaging (to be used with CWS-MX version only)
REC-AD	Receiver for RT03-A infra-red remote control, MD-600 and MD-800 metal diffuser supplied with separate packaging (to be used with CWS-MX version only)
TODS	TODS multifunction control panel (to be used with CWS-MX version only)

Management system for a network of fan coils	
ROUTER-A	Router for BMS systems not provided by Trane
ROB-A	Relay output board

CWE

Cassette Fan Coil Unit with EC Brushless Electronic Motor and Inverter Board

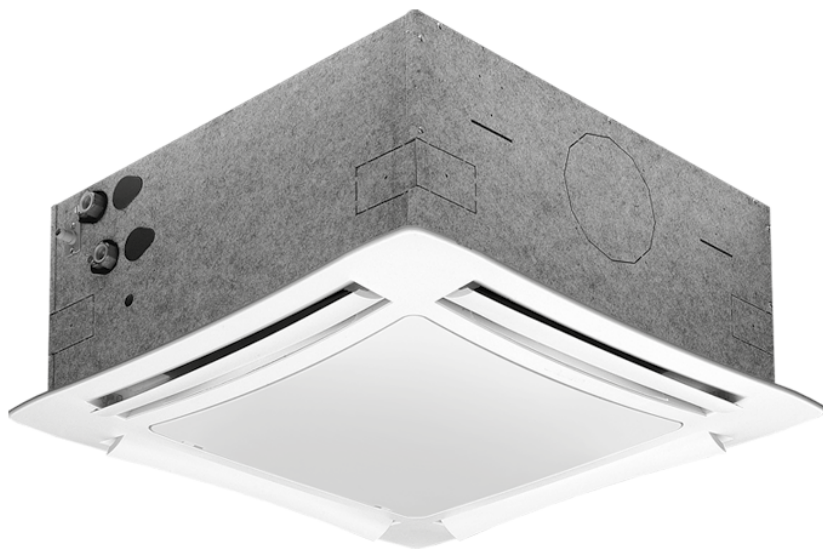

The **CWE** series, available in **5 models**, uses an innovative brushless synchronous permanent magnet electronic motor controlled by an inverter board that is directly installed on the unit.

The air flow can be varied **continuously** with a 1-10 V signal from Trane controls or by independent controllers (programmable controllers with a 1-10 V output). The extreme efficiency, also at a low speed, makes it possible to greatly reduce the electric consumption (more **than 75% less** in comparison to a traditional motor) with absorption values, under normal operating conditions, that are **no greater than 10 Watt** in the entire range.



The brushless motor is characterised by a constant synchronous speed, independently of the applied load, that depends only on the motor power supply frequency, which is modulated by the inverter.

It consumes less because:

- The motor always works at its point of maximum efficiency.
- In the brushless motor, the rotor's permanent magnets generate the magnetising power autonomously.
- The motor always operates at the synchronous speed, as a result there are no induced currents that reduce efficiency

The main advantages are

- Large reduction in energy consumption, thanks to an optimal response to the thermal load of the environment during every moment of the day.
- Operating silence at all rotation speeds.
- Ability to operate at any rotation speed.

All the CWE units can be supplied in MB version. This version allows a wide range of controls, including the infra-red remote control, which can manage one single unit or several units by using the **Modbus RTU - RS 485** communication protocol.



Air diffusers

Intake grid, frame and adjustable air distribution louvers on each side, made from ABS.

DIFF600 / DIFF800 version

white ABS, RAL 9003



DIFF600 / DIFF800 version

intake grid, frame and louvers in a colour of choice



DIFFMD600 / DIFFMD800 version

metal diffuser painted in RAL 9003 white colour to perfectly fit into the false ceiling standard modules without overlapping parts



Casing: made from galvanized steel with internal thermal insulation with polyolefin (PO) foam (B-s2-d0 EN 13501-1) and external anti-condensate lining.

Control equipment:

CWE version: it consists of the pump control circuit board and the inverter circuit board.

CWE-MX version: it consists of the MB board (that integrates pump control) and the inverter board.

Fan assembly: the fan assembly, which is mounted on anti-vibrating supports, is extremely silent.

The radial fan has been designed to optimise performance, using wing profile blades with a shape that reduces turbulence, increasing efficiency and reducing noise.

The fans are connected to a three phase permanent magnet brushless electronic motor that is controlled with reconstructed current according to a **BLAC** sinusoidal wave.

The inverter board that controls the motor operation is powered by 230 Volt, single-phase and, with a **switching system**, it generates a three-phase frequency modulated, wave form power supply.

The electric power supply required for the machine is therefore single-phase with voltage of **230 - 240 V** and frequency of **50 - 60 Hz**.

Coil: made of copper tubes with bonded aluminium fins for maximum transfer contact. The coils have 2 or 3 rows for 2 pipe models and 2+1 rows for 4 pipe models (the heating row is on the inside part of the coil).

For 4 pipe systems two versions are available

- **CWE 14-4P, CWE 44-4P** supply an higher heating emission
- **CWE 26-4P, CWE 36-4P, CWE 56-4P** supply an higher cooling emission.

The coil is not suitable for use in corrosive atmosphere or in environments where aluminium may be subject to corrosion

Condensate collection tray: high density ABS polystyrene foam condensate tray, shaped in order to optimize the air diffusion, fire retardant rating B1 to DIN 4102.

Air filter: synthetic washable filter, easily removable.

Condensate pump: float switch centrifugal pump with 650 mm of maximum head, built into the unit and wired to the control panel on the outside of the casing

Valve set: two or three way valves for ON/OFF operation, with pipe mounting kit and thermostatic actuator.

CWE 12-14 / CWE 22-26 / CWE 32-36
(Version 600 x 600)

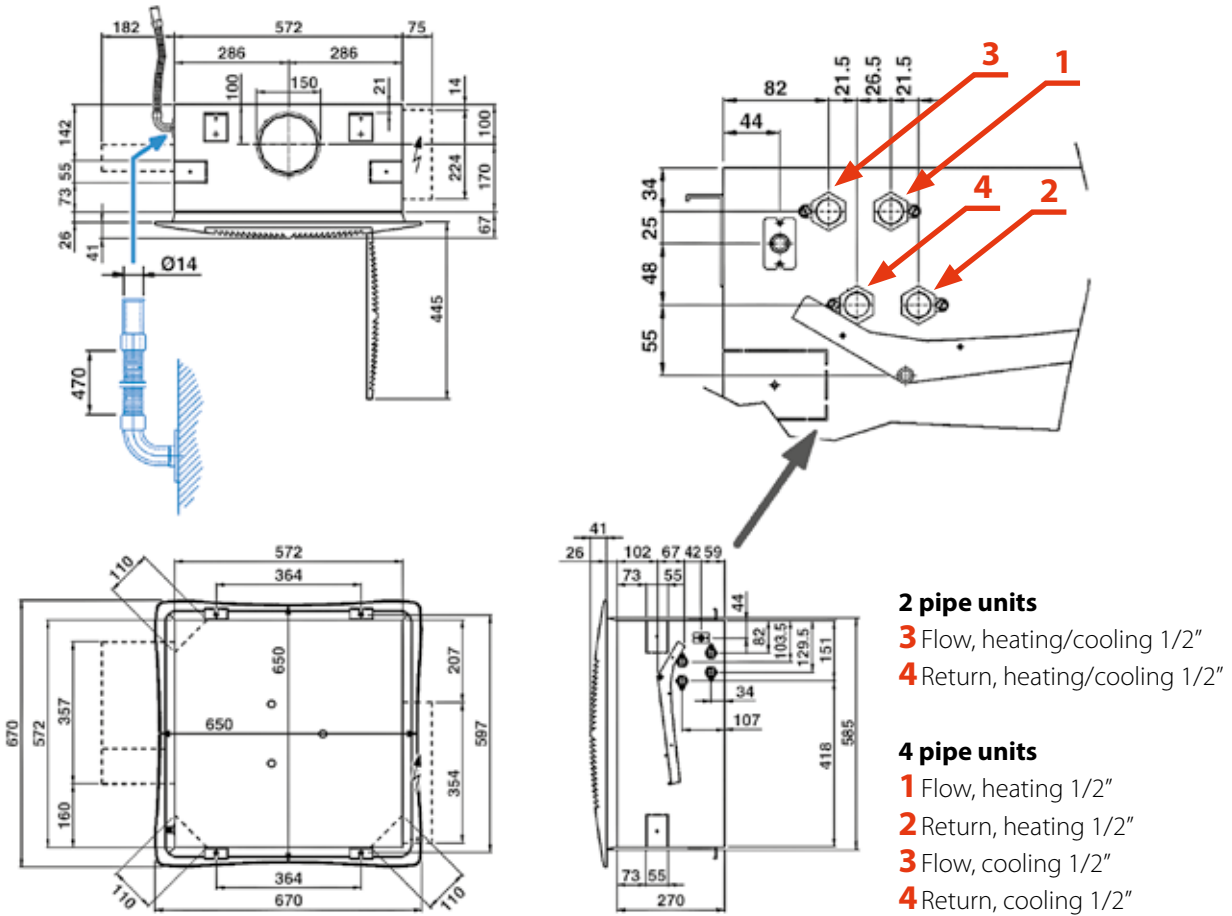

Metal diffuser

MD-600

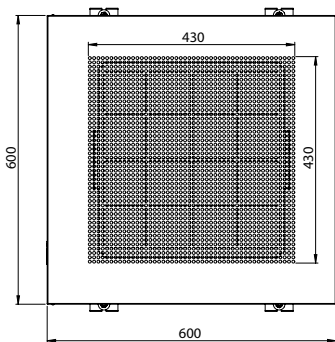

MD-800

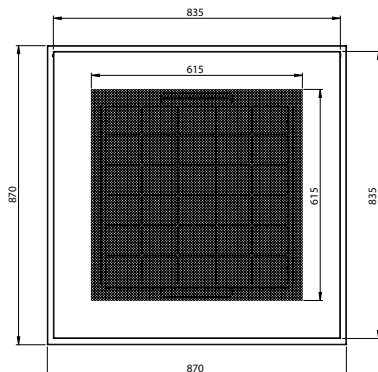

Model	Code
MD-600	9079420
MD-800	9079417

Model	Unit		Diffuser		Packed unit dimensions (mm)			
	Weight packed unit kg	Weight unpacked unit kg	Weight packed unit kg	Weight unpacked unit kg	A	B	C	D
CWE 12	20	17	3,5	2,5	790	350	750	150
CWE 14	22	19						
CWE 22 - 26	21,5	18,5						
CWE 32 - 36	21	18						

CWE 42-44 / CWE 52-56
(Version 800 x 800)

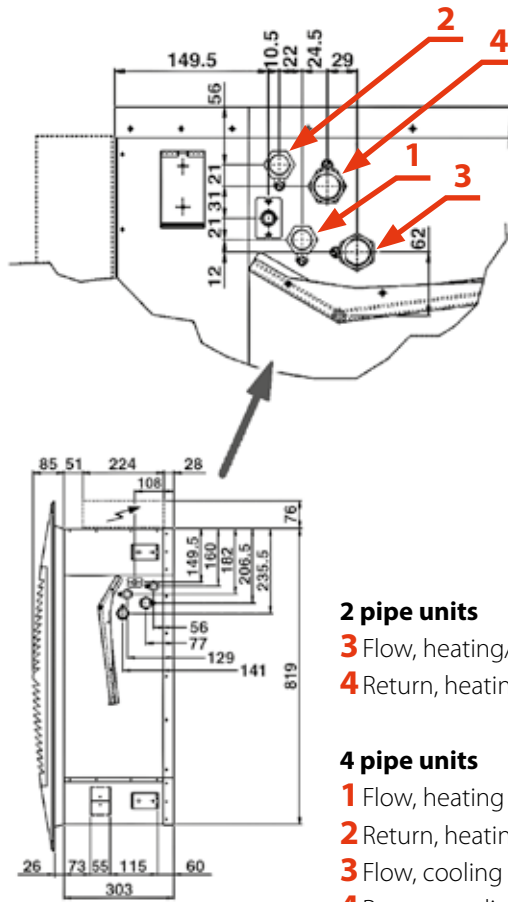
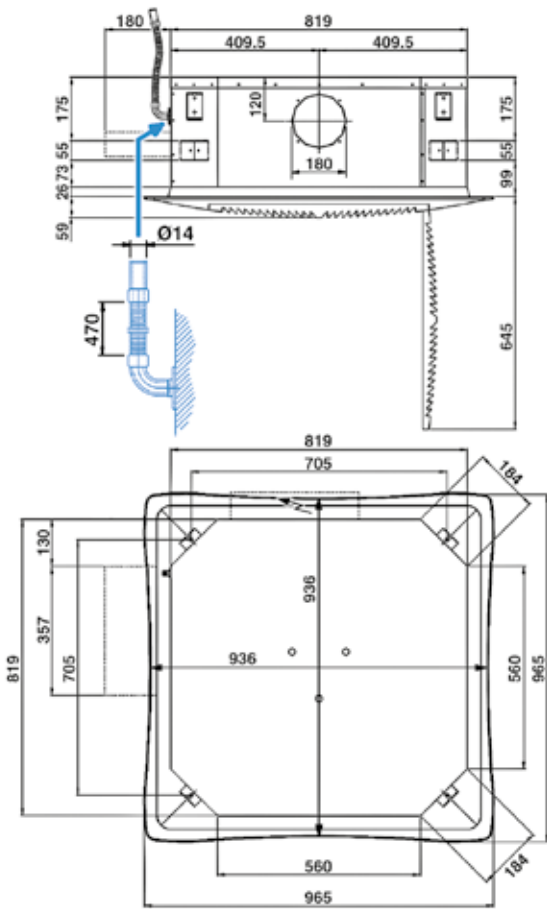

- 2 pipe units**
3 Flow, heating/cooling 3/4"
4 Return, heating/cooling 3/4"
- 4 pipe units**
1 Flow, heating 1/2"
2 Return, heating 1/2"
3 Flow, cooling 3/4"
4 Return, cooling 3/4"

Unit

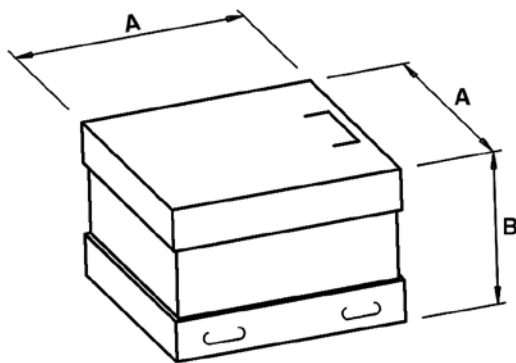

Diffuser

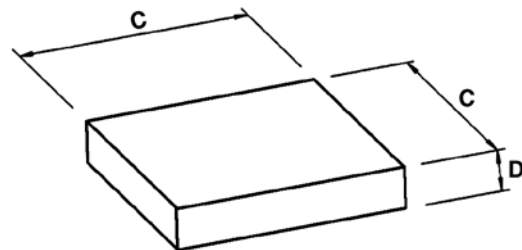

Model	Unit		Diffuser		Packed unit dimensions (mm)			
	Weight packed unit kg	Weight unpacked unit kg	Weight packed unit kg	Weight unpacked unit kg	A	B	C	D
CWE 42	35	31	7	5,5	1050	400	1000	200
CWE 44	40	35						
CWE 52 - 56								

2 pipe units. The following standard rating conditions are used:

COOLING (summer mode)

Entering air temperature: +27°C d.b. +19°C w.b.
Water temperature: +7°C E.W.T. +12°C L.W.T.

HEATING (winter mode)

Entering air temperature: +20°C
Water temperature: +45°C E.W.T. +40°C L.W.T.

Model	CWE 12-2P			CWE 22-2P			CWE 32-2P			CWE 42-2P			CWE 52-2P			
	1	5	10	1	5	10	1	5	10	1	5	10	1	5	10	
Inverter Power																
Speed	MIN	MED	MAX	MIN	MED	MAX	MIN	MED	MAX	MIN	MED	MAX	MIN	MED	MAX	
Air flow	m ³ /h	310	380	535	310	445	710	360	610	880	630	870	1165	710	1130	1770
Cooling total emission (E)	kW	1,84	2,16	2,73	2,24	3,04	4,30	2,55	3,85	4,96	4,20	5,13	6,30	5,28	7,69	10,69
Cooling sensible emission (E)	kW	1,35	1,60	2,07	1,57	2,16	3,15	1,80	2,79	3,68	3,02	3,75	4,69	3,68	5,50	7,83
Heating (E)	kW	1,85	2,22	2,87	2,12	2,98	4,36	2,46	3,85	5,15	4,27	5,30	6,70	4,90	7,34	10,56
Heating - Water 70-60 °C	kW	3,75	4,51	5,82	4,28	6,01	8,81	4,96	7,79	10,42	8,61	10,72	13,54	9,87	14,82	21,37
Dp Cooling (E)	kPa	4,9	6,6	10,1	4,6	11,0	15,1	5,9	12,4	19,7	10,9	15,6	22,7	9,4	18,5	33,0
Dp Heating (E)	kPa	4,3	5,9	9,4	3,6	6,6	13,2	4,7	10,6	17,8	9,6	14,2	21,6	7,0	14,6	28,1
Fan (E)	W	5	8	16	5	11	31	7	21	62	10	17	33	10	32	108
Sound power Lw (E)	dB(A)	33	39	47	33	43	54	37	50	60	33	39	48	34	47	57
Sound pressure Lp (*)	dB(A)	24	30	38	24	34	45	28	41	51	24	30	39	25	38	48
Water content	l	1,4	1,4	1,4	2,1	2,1	2,1	2,1	2,1	2,1	3,0	3,0	3,0	4,0	4,0	4,0
Dimensions	mm	575 x 575 x 275									820 x 820 x 303					

4 pipe units. The following standard rating conditions are used:

COOLING (summer mode)

Entering air temperature: +27°C d.b. +19°C w.b.
Water temperature: +7°C E.W.T. +12°C L.W.T.

HEATING (winter mode)

Entering air temperature: +20°C
Water temperature: +65°C E.W.T. +55°C L.W.T.

Model	CWE 14-4P			CWE 26-4P			CWE 36-4P			CWE 44-4P			CWE 56-4P			
	1	5	10	1	5	10	1	5	10	1	5	10	1	5	10	
Inverter Power																
Speed	MIN	MED	MAX	MIN	MED	MAX	MIN	MED	MAX	MIN	MED	MAX	MIN	MED	MAX	
Air flow	m ³ /h	310	380	535	310	445	710	360	610	880	630	870	1165	710	1130	1770
Cooling total emission (E)	kW	1,85	2,17	2,75	2,09	2,81	3,90	2,37	3,51	4,47	4,29	5,29	6,48	4,97	7,14	9,76
Cooling sensible emission (E)	kW	1,20	1,42	1,84	1,49	2,03	2,92	1,70	2,60	3,40	3,07	3,82	4,80	3,51	5,17	7,29
Heating (E)	kW	2,13	2,51	3,18	1,73	2,20	2,91	1,92	2,66	3,29	5,41	6,65	8,24	4,58	6,27	8,33
Dp Cooling (E)	kPa	4,6	6,2	9,5	3,3	5,6	10,3	4,1	8,4	13,1	9,4	13,6	19,8	8,8	17,0	30,1
Dp Heating (E)	kPa	4,6	6,1	9,4	2,6	4,1	6,7	3,2	5,7	8,4	8,5	12,3	18,1	4,9	8,6	14,3
Fan (E)	W	5	8	16	5	11	31	7	21	62	10	17	33	10	32	108
Sound power Lw (E)	dB(A)	33	39	47	33	43	54	37	50	60	33	39	48	34	47	57
Sound pressure Lp (*)	dB(A)	24	30	38	24	34	45	28	41	51	24	30	39	25	38	48
Cooling water content	l	1,4	1,4	1,4	1,7	1,7	1,7	1,7	1,7	1,7	3,0	3,0	3,0	3,6	3,6	3,6
Heating water content	l	0,7	0,7	0,7	0,5	0,5	0,5	0,5	0,5	0,5	1,4	1,4	1,4	1,1	1,1	1,1
Dimensions	mm	575 x 575 x 275									820 x 820 x 303					

(E) = Eurovent certified performance.

(*) = The sound pressure levels are 9 dB(A) lower than the sound power levels and apply to the reverberant field of a 100 m³ room and a reverberation time of 0.5 sec.

CWE-MX All the CWE units can be supplied in MB version.

This version allows a wide range of controls, including the infra-red remote control, which can manage one single unit or several units by using the Modbus RTU - RS 485 communication protocol.



CWE-X The Cassette 2 pipe models are available with electric heater that is controlled in place of the heating coil valve. The electric heater is controlled in place of the hot water valve and not as integration to it. The electric heater is hermetically sealed and supplied inside the coil pipes and therefore can be only factory mounted. The electric heater of the units are for single phase 230V supply.

ECM Model	Emission
CWE 12-2P-X	1500 W
CWE 22-2P-X / CWE 32-2P-X	2500 W
CWE 42-2P-X / CWE 52-2P-X	3000 W

MCT The **MCT** version has been designed for all environments where false ceilings are not featured or cannot be constructed. The cover cabinet fits perfectly to the air intake and outlet diffuser, maintaining the appealing design that defines the SkyStar series. The water fittings can be turned to point upwards. The **MCT** series includes 7 models, with an installation height of up to 5 m, thanks to the highly flexible adjustment of the air distribution louvers. All the technical specifications described on the previous pages remain the same, while keeping in mind that the **MCT** series features one coil only (two pipe systems), there is no possibility of fresh air intake, there is no possibility of additional electric heater. The **MCT** version features a special casing delivered in separate packaging; this must only be fitted after having installed the SkyStar unit and completed the water and electrical connections.



3 way ON-OFF valves with micrometric lockshield valve

Valve set, 3 ways, ON-OFF, with thermoelectric actuator. The set includes connection pipes and holders.

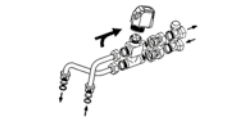

CWE 12-14 / 22-26 / 32-36

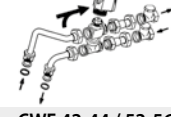

CWE 42-44 / 52-56

2 way ON-OFF valves with micrometric lockshield valve

Valve set, 2 ways, ON-OFF, with thermoelectric actuator. The set includes connection pipes and holders.



CWE 12-14 / 22-26 / 32-36



CWE 42-44 / 52-56

3 way ON-OFF valves with simplified kit

Valve set, 3 ways, ON-OFF, with thermoelectric actuator. The set includes connection pipes.

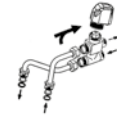

CWE 12-14 / 22-26 / 32-36



CWE 42-44 / 52-56

2 way ON-OFF valves with simplified kit

Valve set, 2 ways, ON-OFF, with thermoelectric actuator. The set includes connection pipes.



CWE 12-14 / 22-26 / 32-36



CWE 42-44 / 52-56

V20VSK Balancing valves independent from the system pressure (Oventrop)
(for main and additional coil)

V2DFSK Balancing valves independent from the system pressure (Danfoss)
(for main and additional coil)

CDA Air distribution connection

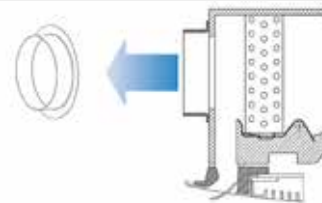

CAP Fresh air connection

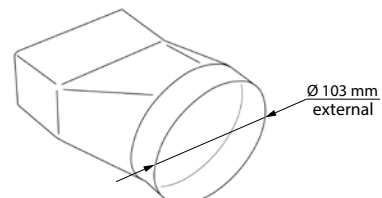

PRT Fresh air kit

This is used to introduce fresh air into the environment directly through the diffuser.

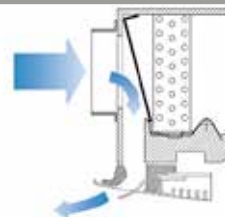

PM-SK Fitted condensate pump with higher pressure head

IAQ accessory refer to "IAQ accessory" at "Cassette accessories" section pages

Electronic wall controls

CWE version	
T-AUTO	Automatic speed control with electronic thermostat and summer/winter switch (to be used with T-POWER-M or T-POWER-A only)
IR-MB2S	IR-MB2S wall control (to be used with T-POWER-M or T-POWER-A only)
T-ECM	Continuous fan speed control with electronic thermostat, summer/winter switch and liquid crystal display
T-POWER-M	T-POWER-A power unit for T-AUTO and IR-MB2S remote controls, fitted on the unit
T-POWER-A	T-POWER-A power unit for T-AUTO and IR-MB2S remote controls, not fitted on the unit

Electronic controls

CWE-MX version	
IR-MB2S	IR-MB2S wall control (to be used with CWE-MX version only)
RT03-REC-A	RT03-A infra-red remote control with receiver supplied with separate packaging (to be used with CWE-MX version only)
RT03-A	RT03-A infra-red remote control supplied with separate packaging (to be used with CWE-MX version only)
REC-A	Receiver for RT03-A infra-red remote control supplied with separate packaging (to be used with CWE-MX version only)
REC-AD	Receiver for RT03-A infra-red remote control, MD-600 and MD-800 metal diffuser supplied with separate packaging (to be used with CWE-MX version only)
TODS	TODS multifunction control panel (to be used with CWE-MX version only)

Management system for a network of fan coils	
ROUTER-A	Router for BMS systems not provided by Trane
ROB-A	Relay output board

CWE



TRANE
TECHNOLOGIES

Trane - by Trane Technologies (NYSE: TT), a global climate innovator - creates comfortable, energy efficient indoor environments for commercial and residential applications. For more information, please visit www.trane.eu or www.tranetechnologies.com

Trane has a policy of continuous product and product data improvement and reserves the right to change design and specifications without notice. We are committed to using environmentally conscious print practices.