

NEW  
GENERATION



Cert. n° 0545

# Fan Coil Units Carisma Floor CFP-ECM

TECHNICAL MANUAL



**Carisma Floor CFP-ECM** fan coil units represent a combination of innovative aesthetics and functionality in an air conditioning system.

They are designed to efficiently heat, cool and ventilate buildings with large windows or doors.

The air flow skims the window in such a way that the units can be placed where people leave. In doing so the design flexibility is increased.

The wide range of models includes solutions which can be customised depending on architectural requirements with diffusion grids in a variety of materials and colours.

The standard lengths available are 7, in 2 or 4 pipe versions. It is possible to adapt the thermal and sound performances to every design requirements, thanks to the innovative fan coil group modularity.

Several combinations are available: out of standard lengths of 50 mm pitch included.

All the units are supplied with low energy consumption electronic motors. A large variety of control and regulation accessories is available. Floor fan coil units are used inside private homes, on verandas, in public offices and buildings and in exhibition and commercial areas.





The choice of **Carisma Floor** units have a lot of advantages:

- **Low energy consumption ECM motor**
- **Low noise**
- **Flexibility**
- **Advanced design**
- **Easy to install**









## CONTENTS

CFP-ECM 2T Version (2 pipe units)	• Construction features	Pag. 6
	• Front connections without integrated valve and dimensions	Pag. 8
	• Side connections without integrated valve and dimensions	Pag. 9
	• Fan specifications	Pag. 10
	• Technical data	Pag. 12
	• Pressure drop	Pag. 19
CFP-ECM 4T Version (4 pipe units)	• Construction features	Pag. 20
	• Front connections without integrated valve and dimensions	Pag. 22
	• Fan specifications	Pag. 23
	• Technical data	Pag. 25
	• Pressure drop	Pag. 32
Regulating valve		Pag. 33
Accessories	• ON-OFF 2-way modulating valve, with actuator 24V	Pag. 34
	• ON-OFF 2-way valve not fitted, with actuator 230V	Pag. 35
	• Cover grid	Pag. 36
	• Accessories and auxiliary products for assembly	Pag. 39
	• Empty casing	Pag. 39
	• Casing fastening and installation	Pag. 39
	• Casing sound absorption lining	Pag. 40
	• Air connections with dampers for flow rate adjustment	Pag. 40
	• Number and position of air connections	Pag. 40
	• Condensate pump	Pag. 41
	• Stand soil brackets	Pag. 41
Management system with TAD digital ambient thermostat	• Management system with TAD digital ambient thermostat	Pag. 42
	• Controls and Accessories	Pag. 46
Management system for a network of fan coils with MB electronic board	• MB-CFP regulation and control board	Pag. 48
	• T-MB Wall control	Pag. 49
	• PSM-DI Multifunction control panel	Pag. 50
	• T-DI Touch screen multifunction control panel and Web Gateway SabWeb	Pag. 51
	• Sabianet	Pag. 52
	• SIOS Accessory	Pag. 56
	• Router-S	Pag. 56
• KNX Bus System	Pag. 57	
Regulation valve		Pag. 57
Special models	• Angle models	Pag. 59
	• Curved models	Pag. 60
	• Models with column	Pag. 61
	• Further special models	Pag. 62
	• Availability on demand	Pag. 62
Further pieces of information	• Assembly and installation advice	Pag. 63
	• Assembly and installation instructions	Pag. 64

## Construction features



**CFP-ECM 2T** version

### Heating and cooling 2 pipe units



Walkable **floor casing** in galvanised steel sheet, coated with Anthracite grey (RAL 7016) powder paint, with external height adjustable system preassembled with an antivibrating device. Condensate collection tray integrated in floor casing, including two side drain connections Ø 15 mm.

**Coil** consisting of copper pipes and aluminium fins, painted Anthracite grey (RAL 7016) and housed, with acoustic decoupling, in transversal galvanised and painted steel frame. Euroconus connection, front or lateral side, with connection nut (int. thread  $\frac{3}{4}$ " and air venting.

**Tangential fan**, window side, with protective cover, 24V EC motors freely adjustable (0–10 V) pre-wired and ready for connection.

**Aluminium roll-up grid** consisting of stable profiles, anodised in natural colours, with 20 x 6 mm slats. Grid with overall height of 20 mm and free 70% transversal section, inserted in floor casing and acoustically insulated by rubber gaskets. Perimeter listel with finish of cover grid (except for wooden grids).

**Mounting cover** with a black plastic **protective profile** of the perimeter listels to protect the fan coil unit during installation.

**The Carisma CFP-ECM units are delivered without regulation board** (accessory available at the "Controls and Accessory" pages).



## Construction features

### Standard version

7 Length - Width 330 mm - Height 130 mm: 900 -1200 – 1400 – 1700 -2000 – 2500 – 3000  
 7 Length - Width 350 mm - Height 175 mm: 1000 – 1200 – 1400 – 1700 – 2000 – 2500 – 3000  
 Special lengths on request (50mm pitch)  
 Aluminium roll-up grid.

### Identifications and Models

Dimensions			Model
Casing Length	Casing Height	Casing Width	
L (mm)	H (mm)	T (mm)	
900	130	330	CFP-ECM 2T 900-130-330
1000	175	350	CFP-ECM 2T 1000-175-350
1200	130	330	CFP-ECM 2T 1200-130-330
	175	350	CFP-ECM 2T 1200-175-350
1400	130	330	CFP-ECM 2T 1400-130-330
	175	350	CFP-ECM 2T 1400-175-350
1700	130	330	CFP-ECM 2T 1700-130-330
	175	350	CFP-ECM 2T 1700-175-350
2000	130	330	CFP-ECM 2T 2000-130-330
	175	350	CFP-ECM 2T 2000-175-350
2500	130	330	CFP-ECM 2T 2500-130-330
	175	350	CFP-ECM 2T 2500-175-350
3000	130	330	CFP-ECM 2T 3000-130-330
	175	350	CFP-ECM 2T 3000-175-350

### Operating principle

#### Forced heating convection

The cold air which skims the windows is suctioned and heated by the coil.  
 The heated air rises, creating a curtain.

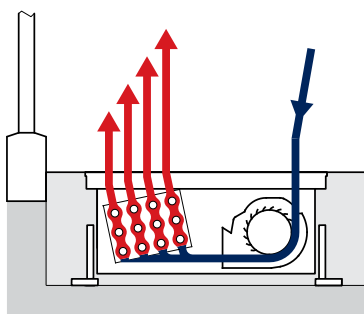

#### Forced cooling convection

Installation in front of the window surfaces efficiently contrasts the diffusion of heat due to solar radiation.

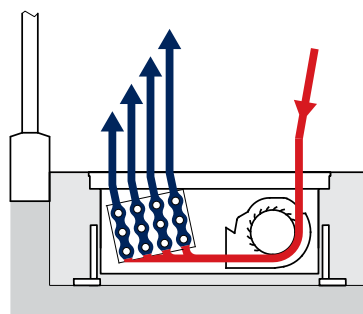

For further information, see the paragraph "Basic notions"

### Operating limits

Highest water inlet temperature: 90 °C.  
 Highest working pressure: 10 bars (high pressure optional model, 16 bars).  
 Test pressure: 13 bars (high pressure optional model, 21 bars).

## Front connections without integrated valve

**A1 - Front left** connections with respect to environment side

**A2 - Front right** connections with respect to environment side

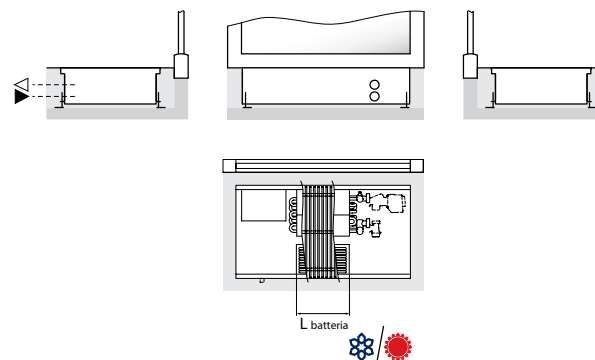
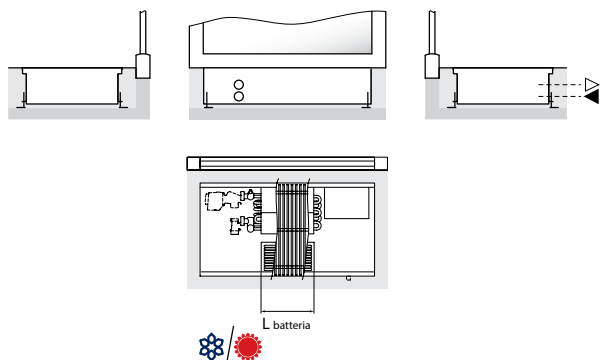

**Coil connection measurement:** euroconus with connection nut (int. thread IG 3/4")

## Dimensions – Front connections diagram (Position A1)

**Left side view**

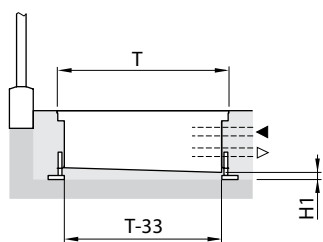

**Front view**

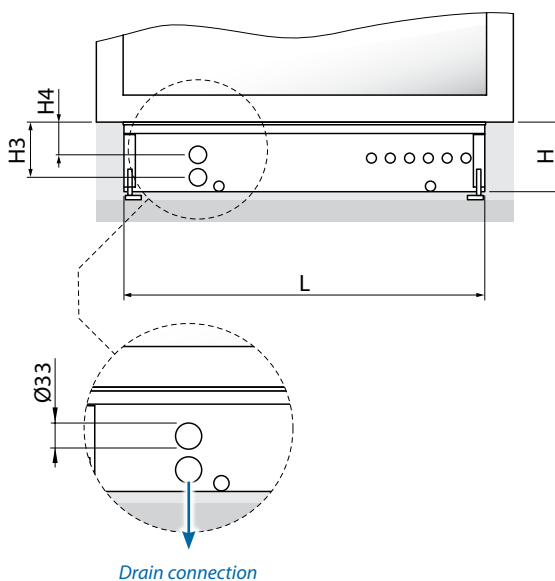

**Right side view**

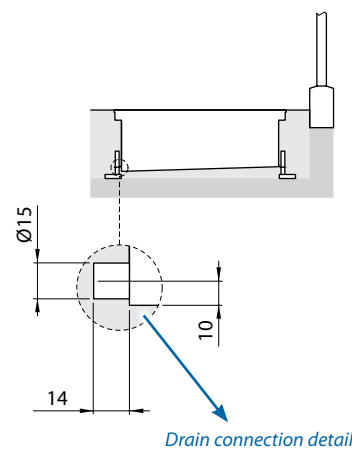

Position A2 specular with respect to Position A1

## Dimensions

L (mm)	T (mm)	H (mm)	H1 (mm)	H3 (mm)	H4 (mm)
up to 3000	330	130	3 - 50	101	61
	350	175	3 - 85	128	84



### Side connections without integrated valve

**A3 - Side left connections with respect to environment side**

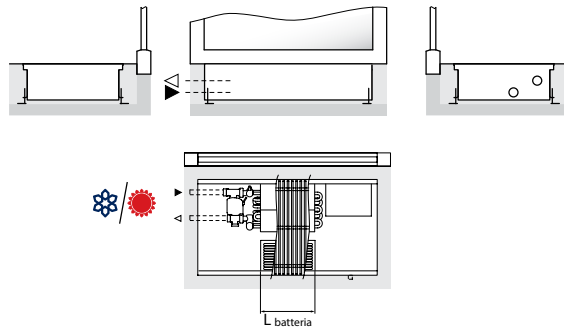

**A4 - Side right connections with respect to environment side**

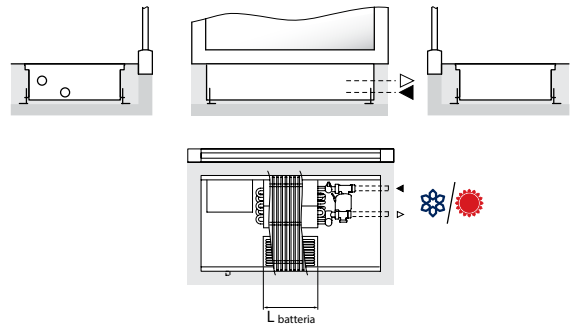

**Coil connection measurement:** euroconus with connection nut (int. thread IG 3/4")

### Dimensions – Side connections diagram (Position A3)

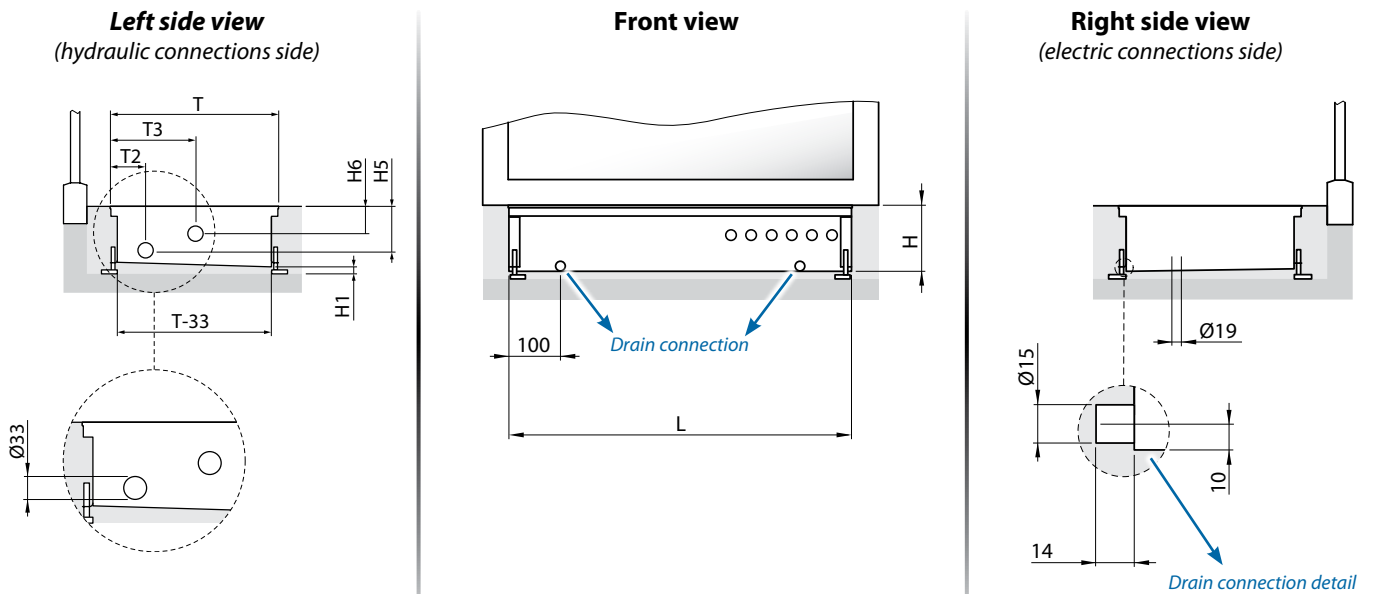

Position A4 specular with respect to Position A3

### Dimensions

L (mm)	T (mm)	T2 (mm)	T3 (mm)	H (mm)	H1 (mm)	H5 (mm)	H6 (mm)
up to 3000	330	68	166	130	3 - 50	86	63
	350	54	170	175	3 - 85	127	79

## Fan specifications

### Tangential fans technical data

Height 130 mm - Width 330 mm							
Length	900	1200	1400	1700	2000	2500	3000
Number of EC motors	1	1	1	1	2	2	2
Number of fans	1	2	3	3	4	5	6
Maximum absorbed power (W)	15	19	21	22	39	42	44
Maximum absorbed current (mA) -20%	625	810	860	920	1620	1730	1840
Maximum air flow rate (m <sup>3</sup> /h) +/-7,5%	300	390	443	470	780	884	940

Height 175 mm - Width 350 mm							
Length	1000	1200	1400	1700	2000	2500	3000
Number of EC motors	1	1	1	2	2	3	3
Number of fans	1	1	1	2	2	3	3
Maximum absorbed power (W)	18	20	24	36	40	56	65
Maximum absorbed current (mA) -20%	750	850	1000	1500	1650	2350	2700
Maximum air flow rate (m <sup>3</sup> /h) +/-7,5%	600	650	690	1200	1280	1860	1990





## Technical data

### Casing length 900/1000 mm - Casing height 130/175 mm

#### 2 pipe units

The following standard rating conditions in accordance with the EN 16430 are used:

#### COOLING (summer mode)

Entering air temperature + 27 °C d.b.

Relative humidity 50%

Model		CFP-ECM 2T 900-130-330				CFP-ECM 2T 1000-175-350				
Casing length <b>L</b>	mm	900				1000				
Casing width <b>T</b>	mm	330				350				
Inverter Power <b>EC</b>	V	3	5	7	10	3	5	7	10	
Air flow <b>QV</b>	m <sup>3</sup> /h	80	143	193	229	204	279	347	455	
<b>Cooling: ΔTm 17,5 K - 7/12 °C</b>	(Total emission)	W	301	766	1039	1204	780	1088	1189	1510
	(Sensible emission)	W	199	517	705	830	568	842	1057	1510
<b>Cooling: ΔTm 12,5 K - 12/17 °C</b>	(Total emission)	W	177	357	515	651	454	621	806	1012
	(Sensible emission)	W	164	357	515	651	454	621	806	1012
<b>Cooling: ΔTm 10,0 K - 16/18 °C</b>	(Total emission)	W	145	283	407	507	404	617	825	1067
	(Sensible emission)	W	145	283	407	507	404	617	825	1067
Sound power <b>L<sup>w</sup></b>	dB(A)	29	36	47	57	38	43	49	58	
Sound pressure <b>LP(*)</b>	dB(A)	20	27	38	48	29	34	40	49	
Weight <b>M</b>	kg	17,33				21,13				

#### HEATING (winter mode)

Entering air temperature + 20°C

Modello		CFP-ECM 2T 900-130-330				CFP-ECM 2T 1000-175-350			
Casing length <b>L</b>	mm	900				1000			
Casing width <b>T</b>	mm	330				350			
Inverter Power <b>EC</b>	V	3	5	7	10	3	5	7	10
Air flow <b>QV</b>	m <sup>3</sup> /h	80	143	193	229	204	279	347	455
<b>Heating: ΔTm 50,0 K - 75/65 °C</b>	W	899	1588	2278	3024	2322	3165	3988	5187
<b>Heating: ΔTm 30,0 K - 55/45 °C</b>	W	536	947	1358	1804	1385	1887	2379	3093
<b>Heating: ΔTm 22,5 K - 45/40 °C</b>	W	404	714	1024	1360	1044	1423	1793	2332
Sound power <b>L<sup>w</sup></b>	dB(A)	29	36	47	57	38	43	49	58
Sound pressure <b>LP(*)</b>	dB(A)	20	27	38	48	29	34	40	49
Weight <b>M</b>	kg	17,33				21,13			

(\*) = The sound pressure levels are 9 dB(A) lower than the sound power levels and apply to the reverberant field of a 100 m<sup>3</sup> room and a reverberation time of 0.5 sec.



## Technical data

### Casing length 1200 mm - Casing height 130/175 mm

#### 2 pipe units

The following standard rating conditions in accordance with the EN 16430 are used:

#### COOLING (summer mode)

Entering air temperature + 27 °C d.b.

Relative humidity 50%

Model		CFP-ECM 2T 1200-130-330				CFP-ECM 2T 1200-175-350				
Casing length <b>L</b>	mm	1200				1200				
Casing width <b>T</b>	mm	330				350				
Inverter Power <b>EC</b>	V	3	5	7	10	3	5	7	10	
Air flow <b>QV</b>	m <sup>3</sup> /h	125	231	323	373	264	370	460	607	
<b>Cooling: ΔTm 17,5 K - 7/12 °C</b>	(Total emission)	W	468	1236	1737	1960	1010	1443	1579	2015
	(Sensible emission)	W	309	835	1178	1351	735	1116	1404	2015
<b>Cooling: ΔTm 12,5 K - 12/17 °C</b>	(Total emission)	W	276	576	860	1060	588	823	1071	1350
	(Sensible emission)	W	255	576	860	1060	588	823	1071	1350
<b>Cooling: ΔTm 10,0 K - 16/18 °C</b>	(Total emission)	W	226	456	681	826	523	818	1095	1424
	(Sensible emission)	W	226	456	681	826	523	818	1095	1424
Sound power <b>L<sup>w</sup></b>	dB(A)	30	38	49	56	35	41	48	57	
Sound pressure <b>L<sup>p</sup>(*)</b>	dB(A)	21	29	40	47	26	32	39	48	
Weight <b>M</b>	kg	22,18				24,94				

#### HEATING (winter mode)

Entering air temperature + 20°C

Modello		CFP-ECM 2T 1200-130-330				CFP-ECM 2T 1200-175-350			
Casing length <b>L</b>	mm	1200				1200			
Casing width <b>T</b>	mm	330				350			
Inverter Power <b>EC</b>	V	3	5	7	10	3	5	7	10
Air flow <b>QV</b>	m <sup>3</sup> /h	125	231	323	373	264	370	460	607
<b>Heating: ΔTm 50,0 K - 75/65 °C</b>	W	1561	2799	4006	4736	3190	4348	5479	7126
<b>Heating: ΔTm 30,0 K - 55/45 °C</b>	W	931	1669	2389	2825	1902	2593	3268	4250
<b>Heating: ΔTm 22,5 K - 45/40 °C</b>	W	702	1259	1801	2130	1434	1955	2464	3204
Sound power <b>L<sup>w</sup></b>	dB(A)	30	38	49	56	35	41	48	57
Sound pressure <b>L<sup>p</sup>(*)</b>	dB(A)	21	29	40	47	26	32	39	48
Weight <b>M</b>	kg	22,18				24,94			

(\*) = The sound pressure levels are 9 dB(A) lower than the sound power levels and apply to the reverberant field of a 100 m<sup>3</sup> room and a reverberation time of 0.5 sec.

## Technical data

### Casing length 1400 mm - Casing height 130/175 mm

#### 2 pipe units

The following standard rating conditions in accordance with the EN 16430 are used:

#### COOLING (summer mode)

Entering air temperature + 27 °C d.b.

Relative humidity 50%

Model		CFP-ECM 2T 1400-130-330				CFP-ECM 2T 1400-175-350				
Casing length <b>L</b>	mm	1400				1400				
Casing width <b>T</b>	mm	330				350				
Inverter Power <b>EC</b>	V	3	5	7	10	3	5	7	10	
Air flow <b>QV</b>	m <sup>3</sup> /h	158	284	396	432	290	412	513	678	
<b>Cooling: ΔTm 17,5 K - 7/12 °C</b>	(Total emission)	W	591	1520	2135	2268	1108	1605	1758	2250
	(Sensible emission)	W	390	1027	1448	1564	806	1242	1563	2250
<b>Cooling: ΔTm 12,5 K - 12/17 °C</b>	(Total emission)	W	348	708	1058	1227	645	915	1193	1508
	(Sensible emission)	W	322	708	1058	1227	645	915	1193	1508
<b>Cooling: ΔTm 10,0 K - 16/18 °C</b>	(Total emission)	W	285	561	837	956	573	911	1220	1591
	(Sensible emission)	W	285	561	837	956	573	911	1220	1591
Sound power <b>L<sup>w</sup></b>	dB(A)	32	39	50	56	33	40	47	57	
Sound pressure <b>LP(*)</b>	dB(A)	23	30	41	47	24	31	38	48	
Weight <b>M</b>	kg	25,75				28,04				

#### HEATING (winter mode)

Entering air temperature + 20°C

Modello		CFP-ECM 2T 1400-130-330				CFP-ECM 2T 1400-175-350			
Casing length <b>L</b>	mm	1400				1400			
Casing width <b>T</b>	mm	330				350			
Inverter Power <b>EC</b>	V	3	5	7	10	3	5	7	10
Air flow <b>QV</b>	m <sup>3</sup> /h	158	284	396	432	290	412	513	678
<b>Heating: ΔTm 50,0 K - 75/65 °C</b>	W	1968	3529	4985	5655	3624	4939	6225	8095
<b>Heating: ΔTm 30,0 K - 55/45 °C</b>	W	1174	2105	2973	3373	2161	2946	3713	4828
<b>Heating: ΔTm 22,5 K - 45/40 °C</b>	W	885	1587	2241	2543	1629	2221	2799	3640
Sound power <b>L<sup>w</sup></b>	dB(A)	32	39	50	56	33	40	47	57
Sound pressure <b>LP(*)</b>	dB(A)	23	30	41	47	24	31	38	48
Weight <b>M</b>	kg	25,75				28,04			

(\*) = The sound pressure levels are 9 dB(A) lower than the sound power levels and apply to the reverberant field of a 100 m<sup>3</sup> room and a reverberation time of 0.5 sec.

## Technical data

### Casing length 1700 mm - Casing height 130/175 mm

#### 2 pipe units

The following standard rating conditions in accordance with the EN 16430 are used:

#### COOLING (summer mode)

Entering air temperature + 27 °C d.b.

Relative humidity 50%

Model		CFP-ECM 2T 1700-130-330				CFP-ECM 2T 1700-175-350				
Casing length <b>L</b>	mm	1700				1700				
Casing width <b>T</b>	mm	330				350				
Inverter Power <b>EC</b>	V	3	5	7	10	3	5	7	10	
Air flow <b>QV</b>	m <sup>3</sup> /h	191	353	471	489	382	560	699	930	
<b>Cooling: ΔTm 17,5 K - 7/12 °C</b>	(Total emission)	W	717	1889	2536	2567	1460	2183	2396	3086
	(Sensible emission)	W	474	1276	1719	1770	1062	1689	2131	3086
<b>Cooling: ΔTm 12,5 K - 12/17 °C</b>	(Total emission)	W	423	880	1256	1389	849	1245	1625	2068
	(Sensible emission)	W	391	880	1256	1389	849	1245	1625	2068
<b>Cooling: ΔTm 10,0 K - 16/18 °C</b>	(Total emission)	W	346	697	994	1082	755	1238	1663	2181
	(Sensible emission)	W	346	697	994	1082	755	1238	1663	2181
Sound power <b>L<sup>w</sup></b>	dB(A)	32	39	50	55	40	46	52	63	
Sound pressure <b>L<sup>p</sup>(*)</b>	dB(A)	23	30	41	46	31	37	43	54	
Weight <b>M</b>	kg	31,00				35,78				

#### HEATING (winter mode)

Entering air temperature + 20°C

Modello		CFP-ECM 2T 1700-130-330				CFP-ECM 2T 1700-175-350			
Casing length <b>L</b>	mm	1700				1700			
Casing width <b>T</b>	mm	330				350			
Inverter Power <b>EC</b>	V	3	5	7	10	3	5	7	10
Air flow <b>QV</b>	m <sup>3</sup> /h	191	353	471	489	382	560	699	930
<b>Heating: ΔTm 50,0 K - 75/65 °C</b>	W	2485	4434	5970	6513	5143	7009	8834	11489
<b>Heating: ΔTm 30,0 K - 55/45 °C</b>	W	1482	2644	3560	3884	3067	4180	5269	6852
<b>Heating: ΔTm 22,5 K - 45/40 °C</b>	W	1117	1994	2684	2929	2312	3152	3972	5166
Sound power <b>L<sup>w</sup></b>	dB(A)	32	39	50	55	40	46	52	63
Sound pressure <b>L<sup>p</sup>(*)</b>	dB(A)	23	30	41	46	31	37	43	54
Weight <b>M</b>	kg	31,00				35,78			

(\*) = The sound pressure levels are 9 dB(A) lower than the sound power levels and apply to the reverberant field of a 100 m<sup>3</sup> room and a reverberation time of 0.5 sec.

## Technical data

### Casing length 2000 mm - Casing height 130/175 mm

#### 2 pipe units

The following standard rating conditions in accordance with the EN 16430 are used:

#### COOLING (summer mode)

Entering air temperature + 27 °C d.b.

Relative humidity 50%

Model		CFP-ECM 2T 2000-130-330				CFP-ECM 2T 2000-175-350				
Casing length <b>L</b>	mm	2000				2000				
Casing width <b>T</b>	mm	330				350				
Inverter Power <b>EC</b>	V	3	5	7	10	3	5	7	10	
Air flow <b>QV</b>	m <sup>3</sup> /h	232	439	578	660	447	675	845	1130	
<b>Cooling: ΔTm 17,5 K - 7/12 °C</b>	(Total emission)	W	871	2352	3112	3464	1707	2633	2896	3749
	(Sensible emission)	W	575	1588	2110	2388	1242	2036	2575	3749
<b>Cooling: ΔTm 12,5 K - 12/17 °C</b>	(Total emission)	W	513	1096	1541	1874	993	1501	1964	2512
	(Sensible emission)	W	474	1096	1541	1874	993	1501	1964	2512
<b>Cooling: ΔTm 10,0 K - 16/18 °C</b>	(Total emission)	W	420	868	1220	1460	883	1493	2009	2650
	(Sensible emission)	W	420	868	1220	1460	883	1493	2009	2650
Sound power <b>L<sup>w</sup></b>	dB(A)	32	40	51	58	38	44	51	61	
Sound pressure <b>LP(*)</b>	dB(A)	23	31	42	49	29	35	42	52	
Weight <b>M</b>	kg	36,78				41,48				

#### HEATING (winter mode)

Entering air temperature + 20°C

Modello		CFP-ECM 2T 2000-130-330				CFP-ECM 2T 2000-175-350			
Casing length <b>L</b>	mm	2000				2000			
Casing width <b>T</b>	mm	330				350			
Inverter Power <b>EC</b>	V	3	5	7	10	3	5	7	10
Air flow <b>QV</b>	m <sup>3</sup> /h	232	439	578	660	447	675	845	1130
<b>Heating: ΔTm 50,0 K - 75/65 °C</b>	W	2980	5383	7727	9489	6445	8748	11071	14397
<b>Heating: ΔTm 30,0 K - 55/45 °C</b>	W	1777	3211	4608	5659	3844	5239	6603	8586
<b>Heating: ΔTm 22,5 K - 45/40 °C</b>	W	1340	2421	3474	4267	2898	3950	4978	6474
Sound power <b>L<sup>w</sup></b>	dB(A)	32	40	51	58	38	44	51	61
Sound pressure <b>LP(*)</b>	dB(A)	23	31	42	49	29	35	42	52
Weight <b>M</b>	kg	36,78				41,48			

(\*) = The sound pressure levels are 9 dB(A) lower than the sound power levels and apply to the reverberant field of a 100 m<sup>3</sup> room and a reverberation time of 0.5 sec.



## Technical data

### Casing length 2500 mm - Casing height 130/175 mm

#### 2 pipe units

The following standard rating conditions in accordance with the EN 16430 are used:

#### COOLING (summer mode)

Entering air temperature + 27 °C d.b.

Relative humidity 50%

Model		CFP-ECM 2T 2500-130-330				CFP-ECM 2T 2500-175-350				
Casing length <b>L</b>	mm	2500				2500				
Casing width <b>T</b>	mm	330				350				
Inverter Power <b>EC</b>	V	3	5	7	10	3	5	7	10	
Air flow <b>QV</b>	m <sup>3</sup> /h	305	580	739	770	602	917	1148	1538	
<b>Cooling: ΔTm 17,5 K - 7/12 °C</b>	(Total emission)	W	1142	3107	3979	4042	2302	3576	3935	5102
	(Sensible emission)	W	755	2098	2698	2787	1675	2766	3499	5102
<b>Cooling: ΔTm 12,5 K - 12/17 °C</b>	(Total emission)	W	673	1448	1971	2186	1339	2039	2669	3419
	(Sensible emission)	W	622	1448	1971	2186	1339	2039	2669	3419
<b>Cooling: ΔTm 10,0 K - 16/18 °C</b>	(Total emission)	W	551	1146	1560	1703	1191	2029	2730	3607
	(Sensible emission)	W	551	1146	1560	1703	1191	2029	2730	3607
Sound power <b>L<sup>w</sup></b>	dB(A)	33	41	52	58	39	45	51	61	
Sound pressure <b>L<sup>p</sup>(*)</b>	dB(A)	24	32	43	49	30	36	42	52	
Weight <b>M</b>	kg	45,63				53,11				

#### HEATING (winter mode)

Entering air temperature + 20°C

Modello		CFP-ECM 2T 2500-130-330				CFP-ECM 2T 2500-175-350			
Casing length <b>L</b>	mm	2500				2500			
Casing width <b>T</b>	mm	330				350			
Inverter Power <b>EC</b>	V	3	5	7	10	3	5	7	10
Air flow <b>QV</b>	m <sup>3</sup> /h	305	580	739	770	602	917	1148	1538
<b>Heating: ΔTm 50,0 K - 75/65 °C</b>	W	3910	7075	9859	11237	8832	12037	15171	19729
<b>Heating: ΔTm 30,0 K - 55/45 °C</b>	W	2332	4219	5880	6702	5267	7179	9048	11766
<b>Heating: ΔTm 22,5 K - 45/40 °C</b>	W	1758	3181	4433	5063	3971	5412	6822	8871
Sound power <b>L<sup>w</sup></b>	dB(A)	33	41	52	58	39	45	51	61
Sound pressure <b>L<sup>p</sup>(*)</b>	dB(A)	24	32	43	49	30	36	42	52
Weight <b>M</b>	kg	45,63				53,11			

(\*) = The sound pressure levels are 9 dB(A) lower than the sound power levels and apply to the reverberant field of a 100 m<sup>3</sup> room and a reverberation time of 0.5 sec.

## Technical data

### Casing length 3000 mm - Casing height 130/175 mm

#### 2 pipe units

The following standard rating conditions in accordance with the EN 16430 are used:

#### COOLING (summer mode)

Entering air temperature + 27 °C d.b.

Relative humidity 50%

Model		CFP-ECM 2T 3000-130-330				CFP-ECM 2T 3000-175-350				
Casing length <b>L</b>	mm	3000				3000				
Casing width <b>T</b>	mm	330				350				
Inverter Power <b>EC</b>	V	3	5	7	10	3	5	7	10	
Air flow <b>QV</b>	m <sup>3</sup> /h	365	693	810	855	751	1143	1430	1916	
<b>Cooling: ΔTm 17,5 K - 7/12 °C</b>	(Total emission)	W	1370	3710	4488	4604	2867	4454	4902	6355
	(Sensible emission)	W	905	2506	3094	3122	2087	3446	4359	6355
<b>Cooling: ΔTm 12,5 K - 12/17 °C</b>	(Total emission)	W	807	1729	2281	2427	1668	2540	3325	4259
	(Sensible emission)	W	746	1729	2281	2427	1668	2540	3325	4259
<b>Cooling: ΔTm 10,0 K - 16/18 °C</b>	(Total emission)	W	661	1369	1804	1891	1483	2527	3401	4493
	(Sensible emission)	W	661	1369	1804	1891	1483	2527	3401	4493
Sound power <b>L<sup>w</sup></b>	dB(A)	33	41	52	57	36	42	49	60	
Sound pressure <b>LP(*)</b>	dB(A)	24	32	43	48	27	33	40	51	
Weight <b>M</b>	kg	53,74				62,6				

#### HEATING (winter mode)

Entering air temperature + 20°C

Modello		CFP-ECM 2T3000-130-330				CFP-ECM 2T 3000-175-350			
Casing length <b>L</b>	mm	3000				3000			
Casing width <b>T</b>	mm	330				350			
Inverter Power <b>EC</b>	V	3	5	7	10	3	5	7	10
Air flow <b>QV</b>	m <sup>3</sup> /h	365	693	810	855	751	1143	1430	1916
<b>Heating: ΔTm 50,0 K - 75/65 °C</b>	W	4553	8242	11158	12190	11002	14995	18898	24577
<b>Heating: ΔTm 30,0 K - 55/45 °C</b>	W	2715	4915	6655	7270	6561	8943	11271	14648
<b>Heating: ΔTm 22,5 K - 45/40 °C</b>	W	2047	3706	5017	5481	4947	6742	8498	11051
Sound power <b>L<sup>w</sup></b>	dB(A)	33	41	52	57	36	42	49	60
Sound pressure <b>LP(*)</b>	dB(A)	24	32	43	48	27	33	40	51
Weight <b>M</b>	kg	53,74				62,6			

(\*) = The sound pressure levels are 9 dB(A) lower than the sound power levels and apply to the reverberant field of a 100 m<sup>3</sup> room and a reverberation time of 0.5 sec.

## Pressure drop

### Height 130 mm - Length 330 mm / Heating and Cooling

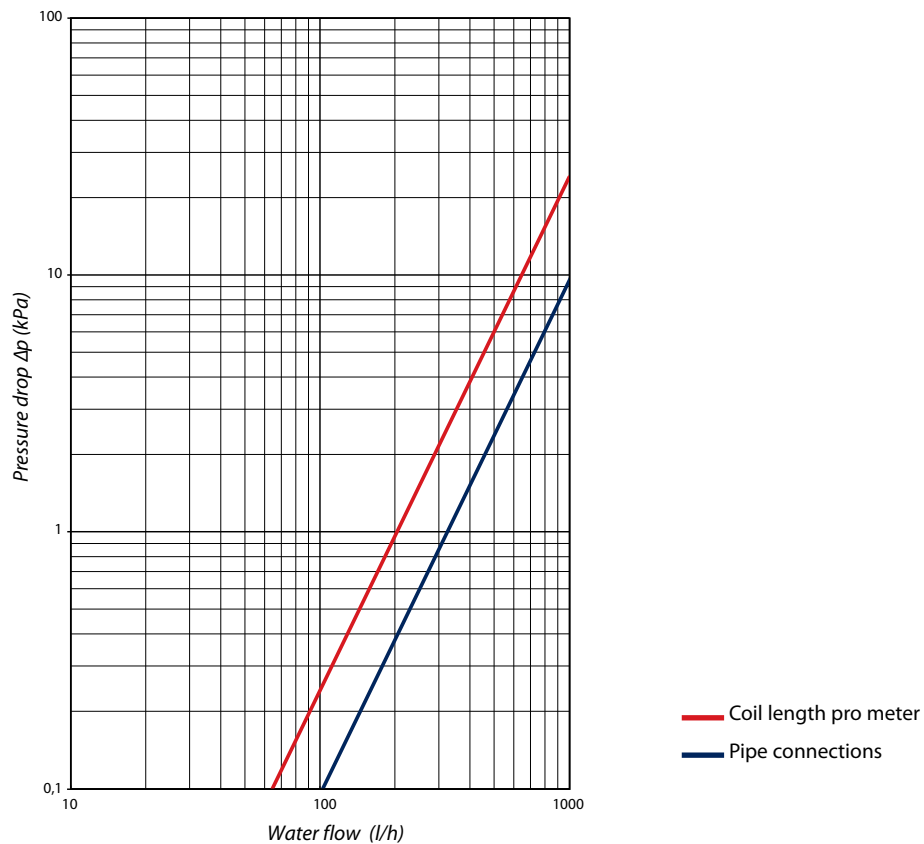

### Height 175 mm - Length 350 mm / Heating and Cooling

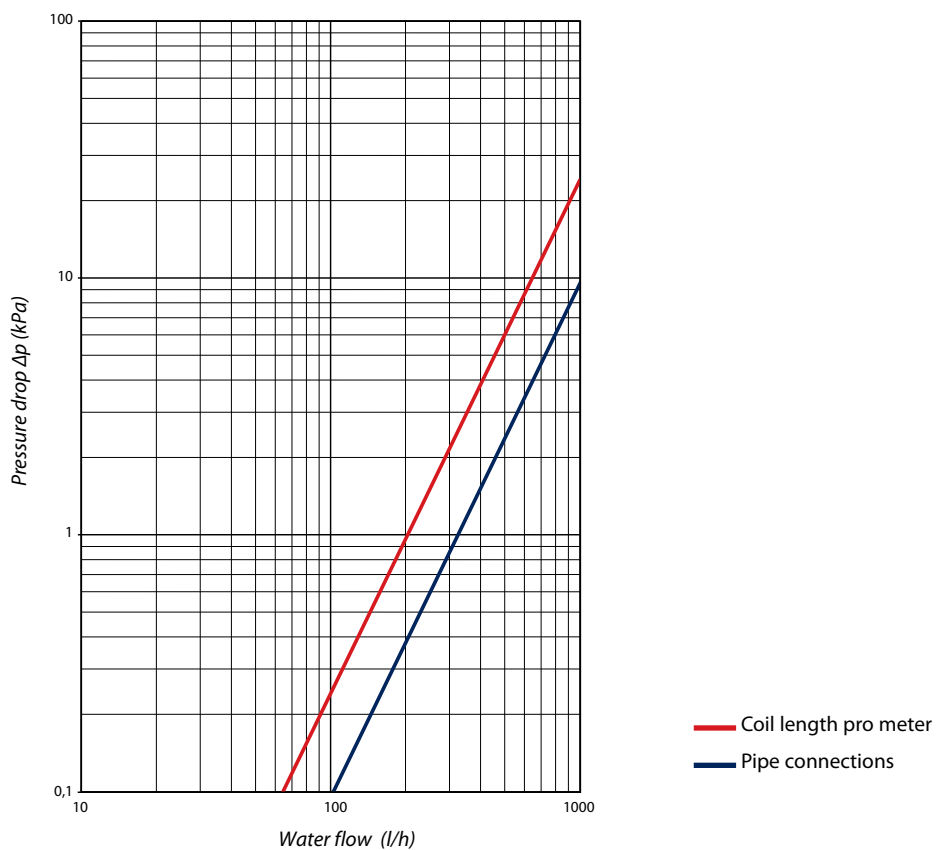

## Construction features



### CFP-ECM 4T version

### Heating and cooling 4 pipe units

Walkable **floor casing** in galvanised steel sheet, coated with Anthracite grey (RAL 7016) powder paint, with external height adjustable system preassembled with an antivibrating device. Condensate collection tray integrated in floor casing, including two side drain connections Ø 15 mm.

**Coil** consisting of copper pipes and aluminium fins, painted Anthracite grey (RAL 7016) and housed, with acoustic decoupling, in transversal galvanised and painted steel frame. Euroconus connection, front or lateral side, with connection nut (int. thread 3/4") and air venting.

**Tangential fan**, window side, with protective cover, 24V EC motors freely adjustable (0-10 V) pre-wired and ready for connection.



**Aluminium roll-up grid** consisting of stable profiles, anodised in natural colours, with 20 x 6 mm slats. Grid with overall height of 20 mm and free 70% transversal section, inserted in floor casing and acoustically insulated by rubber gaskets. Perimeter listel with finish of cover grid (except for wooden grids).

**Mounting cover** with a black plastic **protective profile** of the perimeter listels to protect the fan coil unit during installation.

**The Carisma CFP-ECM units are delivered without regulation board** (accessory available at the "Controls and Accessory" pages).





## Construction features

### Standard version

7 Length - Width 330 mm - Height 130 mm: 900 -1200 – 1400 – 1700 -2000 – 2500 – 3000  
 7 Length - Width 350 mm - Height 175 mm: 1000 – 1200 – 1400 – 1700 – 2000 – 2500 – 3000  
 Special lengths on request (50mm pitch)  
 Aluminium roll-up grid.

### Identifications and Models

Dimensions			Model
Casing Length	Casing Height	Casing Width	
L (mm)	H (mm)	T (mm)	
900	130	330	CFP-ECM 4T 900-130-330
1000	175	350	CFP-ECM 4T 1000-175-350
1200	130	330	CFP-ECM 4T 1200-130-330
	175	350	CFP-ECM 4T 1200-175-350
1400	130	330	CFP-ECM 4T 1400-130-330
	175	350	CFP-ECM 4T 1400-175-350
1700	130	330	CFP-ECM 4T 1700-130-330
	175	350	CFP-ECM 4T 1700-175-350
2000	130	330	CFP-ECM 4T 2000-130-330
	175	350	CFP-ECM 4T 2000-175-350
2500	130	330	CFP-ECM 4T 2500-130-330
	175	350	CFP-ECM 4T 2500-175-350
3000	130	330	CFP-ECM 4T 3000-130-330
	175	350	CFP-ECM 4T 3000-175-350

### Operating principle

#### Forced heating convection

The cold air which skims the windows is suctioned and heated by the coil.  
 The heated air rises, creating a curtain.

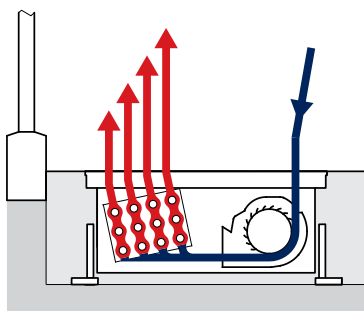

#### Forced cooling convection

Installation in front of the window surfaces efficiently contrasts the diffusion of heat due to solar radiation.

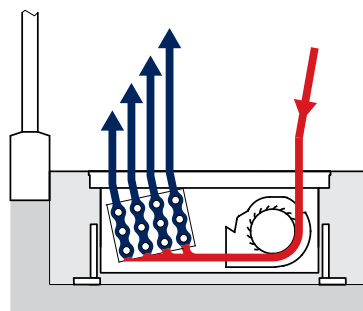

### Operating limits

Highest water inlet temperature: 90 °C.  
 Highest working pressure: 10 bars (high pressure optional model, 16 bars).  
 Test pressure: 13 bars (high pressure optional model, 21 bars).

## Side connections without integrated valve

*Front connections with respect to environment side*

**A5 - Side left connections with respect to environment side**

**A6 - Side right connections with respect to environment side**

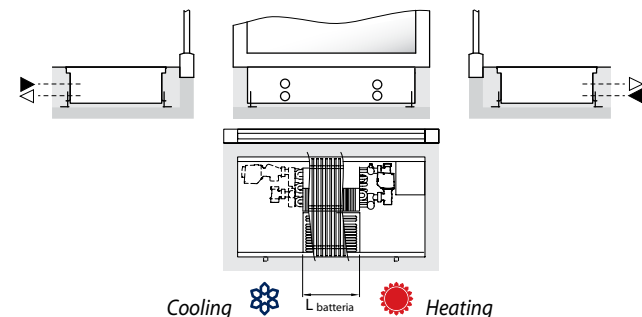
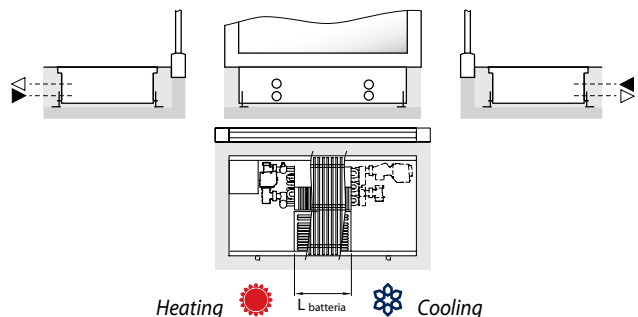

**Coil connection measurement:** euroconus with connection nut (int. thread IG 3/4")

## Dimensions – Side connections diagram (Position A5)

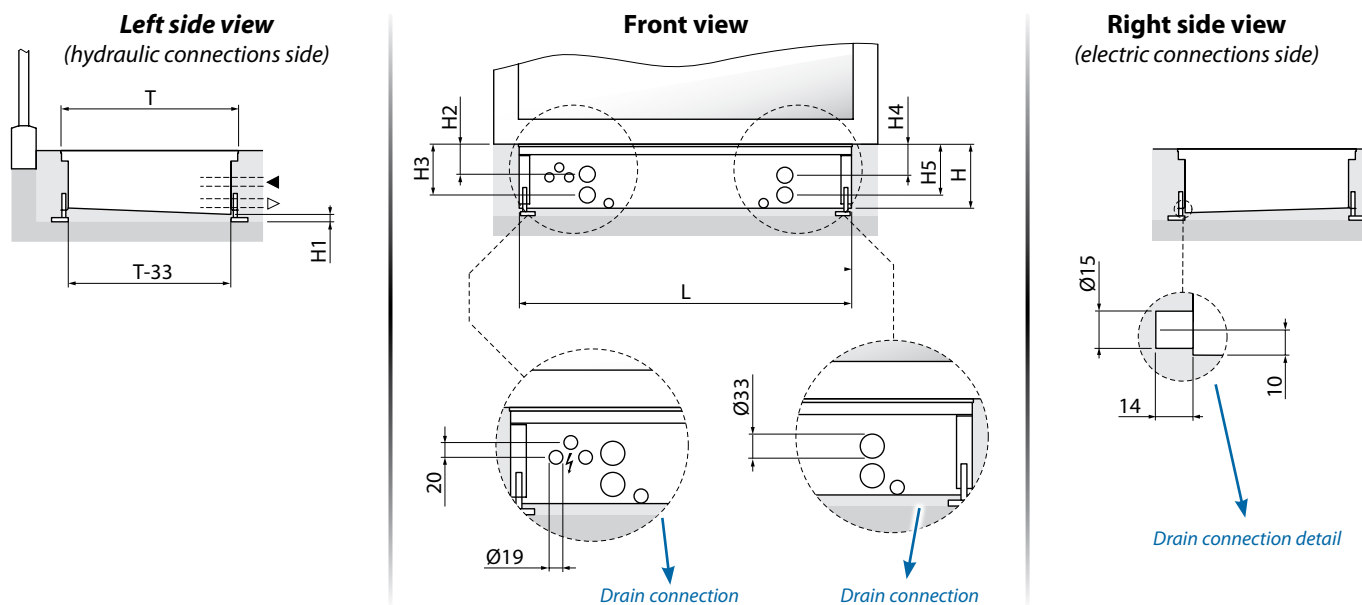

*Position A6 specular with respect to Position A5*

## Dimensions

L (mm)	T (mm)	H (mm)	H1 (mm)	H2 (mm)	H3 (mm)	H4 (mm)	H5 (mm)
up to 3000	330	130	3 - 50	61	101	61	101
	350	175	3 - 85	84	128	84	128

## Fan specifications

### Tangential fans technical data

Height 130 mm - Width 330 mm							
Length	900	1200	1400	1700	2000	2500	3000
Number of EC motors	1	1	1	1	2	2	2
Number of fans	1	2	2	3	4	5	6
Maximum absorbed power (W)	15	18	19	22	38	41	44
Maximum absorbed current (mA) -20%	625	730	810	920	1580	1710	1840
Maximum air flow rate (m <sup>3</sup> /h) +/-7,5%	250	357	414	470	760	884	940

Height 175 mm - Width 350 mm							
Length	1000	1200	1400	1700	2000	2500	3000
Number of EC motors	1	1	1	2	2	2	3
Number of fans	1	1	1	2	2	2	3
Maximum absorbed power (W)	17	19	20	35	38	48	61
Maximum absorbed current (mA) -20%	700	800	850	1450	1600	2000	2550
Maximum air flow rate (m <sup>3</sup> /h) +/-7,5%	510	630	650	1160	1260	1380	1950



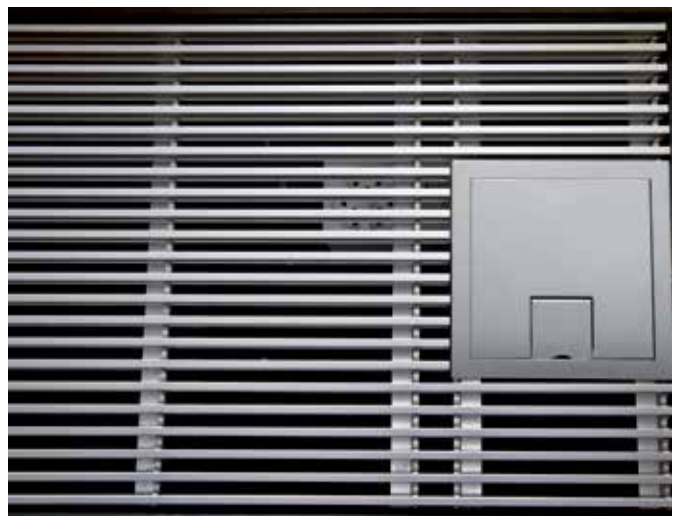



## Technical data

### Casing length 900/1000 mm - Casing height 130/175 mm

#### 4 pipe units

The following standard rating conditions in accordance with the EN 16430 are used:

#### COOLING (summer mode)

Entering air temperature + 27 °C d.b.

Relative humidity 50%

Model		CFP-ECM 4T 900-130-330				CFP-ECM 4T 1000-175-350				
Casing length <b>L</b>	mm	900				1000				
Casing width <b>T</b>	mm	330				350				
Inverter Power <b>EC</b>	V	3	5	7	10	3	5	7	10	
Air flow <b>QV</b>	m <sup>3</sup> /h	68	113	149	171	161	216	265	342	
<b>Cooling: ΔTm 17,5 K - 7/12 °C</b>	(Total emission)	W	255	607	804	900	617	842	909	1133
	(Sensible emission)	W	169	410	545	620	449	651	808	1133
<b>Cooling: ΔTm 12,5 K - 12/17 °C</b>	(Total emission)	W	150	283	398	487	359	480	616	759
	(Sensible emission)	W	139	283	398	487	359	480	616	759
<b>Cooling: ΔTm 10,0 K - 16/18 °C</b>	(Total emission)	W	123	224	315	379	319	477	630	801
	(Sensible emission)	W	123	224	315	379	319	477	630	801
Sound power <b>L<sub>w</sub></b>	dB(A)	29	36	47	57	40	44	50	59	
Sound pressure <b>L<sub>p</sub>(*)</b>	dB(A)	20	27	38	48	31	35	41	50	
Weight <b>M</b>	kg	16,76				20,15				

#### HEATING (winter mode)

Entering air temperature + 20°C

Modello		CFP-ECM 4T 900-130-330				CFP-ECM 4T 1000-175-350			
Casing length <b>L</b>	mm	900				1000			
Casing width <b>T</b>	mm	330				350			
Inverter Power <b>EC</b>	V	3	5	7	10	3	5	7	10
Air flow <b>QV</b>	m <sup>3</sup> /h	68	113	149	171	161	216	265	342
<b>Heating: ΔTm 50,0 K - 75/65 °C</b>	W	664	1137	1580	1999	1529	2984	2627	3416
<b>Heating: ΔTm 30,0 K - 55/45 °C</b>	W	396	678	942	1192	912	1243	1567	2037
<b>Heating: ΔTm 22,5 K - 45/40 °C</b>	W	298	511	710	899	688	937	1181	1536
Sound power <b>L<sub>w</sub></b>	dB(A)	29	36	47	57	40	44	50	59
Sound pressure <b>L<sub>p</sub>(*)</b>	dB(A)	20	27	38	48	31	35	41	50
Weight <b>M</b>	kg	16,76				20,15			

(\*) = The sound pressure levels are 9 dB(A) lower than the sound power levels and apply to the reverberant field of a 100 m<sup>3</sup> room and a reverberation time of 0.5 sec.

## Technical data

### Casing length 1200 mm - Casing height 130/175 mm

#### 4 pipe units

The following standard rating conditions in accordance with the EN 16430 are used:

#### COOLING (summer mode)

Entering air temperature + 27 °C d.b.

Relative humidity 50%

Model		CFP-ECM 4T 1200-130-330				CFP-ECM 4T 1200-175-350				
Casing length <b>L</b>	mm	1200				1200				
Casing width <b>T</b>	mm	330				350				
Inverter Power <b>EC</b>	V	3	5	7	10	3	5	7	10	
Air flow <b>QV</b>	m <sup>3</sup> /h	103	184	250	279	227	311	382	495	
<b>Cooling: ΔTm 17,5 K - 7/12 °C</b>	(Total emission)	W	386	987	1346	1465	868	1212	1311	1642
	(Sensible emission)	W	255	667	913	1010	632	937	1166	1642
<b>Cooling: ΔTm 12,5 K - 12/17 °C</b>	(Total emission)	W	228	460	667	792	505	691	889	1101
	(Sensible emission)	W	210	460	667	792	505	691	889	1101
<b>Cooling: ΔTm 10,0 K - 16/18 °C</b>	(Total emission)	W	186	364	528	617	449	687	910	1161
	(Sensible emission)	W	186	364	528	617	449	687	910	1161
Sound power <b>L<sup>w</sup></b>	dB(A)	30	38	49	56	37	42	48	58	
Sound pressure <b>LP(*)</b>	dB(A)	21	29	40	47	28	33	39	49	
Weight <b>M</b>	kg	21,1				23,96				

#### HEATING (winter mode)

Entering air temperature + 20°C

Modello		CFP-ECM 4T 1200-130-330				CFP-ECM 4T 1200-175-350			
Casing length <b>L</b>	mm	1200				1200			
Casing width <b>T</b>	mm	330				350			
Inverter Power <b>EC</b>	V	3	5	7	10	3	5	7	10
Air flow <b>QV</b>	m <sup>3</sup> /h	103	184	250	279	227	311	382	495
<b>Heating: ΔTm 50,0 K - 75/65 °C</b>	W	1131	1974	2761	3355	2232	3042	3834	4987
<b>Heating: ΔTm 30,0 K - 55/45 °C</b>	W	675	1177	1647	2001	1331	1814	2287	2974
<b>Heating: ΔTm 22,5 K - 45/40 °C</b>	W	509	888	1241	1508	1004	1368	1724	2242
Sound power <b>L<sup>w</sup></b>	dB(A)	30	38	49	56	37	42	48	58
Sound pressure <b>LP(*)</b>	dB(A)	21	29	40	47	28	33	39	49
Weight <b>M</b>	kg	21,1				23,96			

(\*) = The sound pressure levels are 9 dB(A) lower than the sound power levels and apply to the reverberant field of a 100 m<sup>3</sup> room and a reverberation time of 0.5 sec.

## Technical data

### Casing length 1400 mm - Casing height 130/175 mm

#### 4 pipe units

The following standard rating conditions in accordance with the EN 16430 are used:

#### COOLING (summer mode)

Entering air temperature + 27 °C d.b.

Relative humidity 50%

Model		CFP-ECM 4T 1400-130-330				CFP-ECM 4T 1400-175-350				
Casing length <b>L</b>	mm	1400				1400				
Casing width <b>T</b>	mm	330				350				
Inverter Power <b>EC</b>	V	3	5	7	10	3	5	7	10	
Air flow <b>QV</b>	m <sup>3</sup> /h	132	236	323	362	258	357	440	571	
<b>Cooling: ΔTm 17,5 K - 7/12 °C</b>	(Total emission)	W	495	1266	1739	1898	985	1392	1508	1894
	(Sensible emission)	W	327	855	1179	1309	717	1077	1341	1894
<b>Cooling: ΔTm 12,5 K - 12/17 °C</b>	(Total emission)	W	291	590	861	1027	573	794	1023	1269
	(Sensible emission)	W	269	590	861	1027	573	794	1023	1269
<b>Cooling: ΔTm 10,0 K - 16/18 °C</b>	(Total emission)	W	239	467	681	800	510	790	1046	1339
	(Sensible emission)	W	239	467	681	800	510	790	1046	1339
Sound power <b>L<sub>w</sub></b>	dB(A)	30	38	49	56	35	41	48	57	
Sound pressure <b>L<sub>p</sub>(*)</b>	dB(A)	21	29	40	47	26	32	39	48	
Weight <b>M</b>	kg	24,41				27,05				

#### HEATING (winter mode)

Entering air temperature + 20°C

Modello		CFP-ECM 4T 1400-130-330				CFP-ECM 4T 1400-175-350			
Casing length <b>L</b>	mm	1400				1400			
Casing width <b>T</b>	mm	330				350			
Inverter Power <b>EC</b>	V	3	5	7	10	3	5	7	10
Air flow <b>QV</b>	m <sup>3</sup> /h	132	236	323	362	258	357	440	571
<b>Heating: ΔTm 50,0 K - 75/65 °C</b>	W	1491	2616	3649	4009	2584	3521	4438	5772
<b>Heating: ΔTm 30,0 K - 55/45 °C</b>	W	890	1560	2176	2391	1541	2100	2647	3442
<b>Heating: ΔTm 22,5 K - 45/40 °C</b>	W	671	1176	1641	1803	1162	1583	1996	2595
Sound power <b>L<sub>w</sub></b>	dB(A)	30	38	49	56	35	41	48	57
Sound pressure <b>L<sub>p</sub>(*)</b>	dB(A)	21	29	40	47	26	32	39	48
Weight <b>M</b>	kg	24,41				27,05			

(\*) = The sound pressure levels are 9 dB(A) lower than the sound power levels and apply to the reverberant field of a 100 m<sup>3</sup> room and a reverberation time of 0.5 sec.

## Technical data

### Casing length 1700 mm - Casing height 130/175 mm

#### 4 pipe units

The following standard rating conditions in accordance with the EN 16430 are used:

#### COOLING (summer mode)

Entering air temperature + 27 °C d.b.

Relative humidity 50%

Model		CFP-ECM 4T 1700-130-330				CFP-ECM 4T 1700-175-350				
Casing length <b>L</b>	mm	1700				1700				
Casing width <b>T</b>	mm	330				350				
Inverter Power <b>EC</b>	V	3	5	7	10	3	5	7	10	
Air flow <b>QV</b>	m <sup>3</sup> /h	179	323	432	442	360	515	625	830	
<b>Cooling: ΔTm 17,5 K - 7/12 °C</b>	(Total emission)	W	673	1729	2324	2321	1375	2007	2178	2754
	(Sensible emission)	W	445	1168	1576	1600	1001	1552	1937	2754
<b>Cooling: ΔTm 12,5 K - 12/17 °C</b>	(Total emission)	W	396	806	1151	1256	800	1144	1478	1846
	(Sensible emission)	W	366	806	1151	1256	800	1144	1478	1846
<b>Cooling: ΔTm 10,0 K - 16/18 °C</b>	(Total emission)	W	324	638	911	978	711	1138	1511	1947
	(Sensible emission)	W	324	638	911	978	711	1138	1511	1947
Sound power <b>L<sup>w</sup></b>	dB(A)	32	39	50	55	41	47	53	63	
Sound pressure <b>LP(*)</b>	dB(A)	23	30	41	46	32	38	44	54	
Weight <b>M</b>	kg	30,46				34,80				

#### HEATING (winter mode)

Entering air temperature + 20°C

Modello		CFP-ECM 4T 1700-130-330				CFP-ECM 4T 1700-175-350			
Casing length <b>L</b>	mm	1700				1700			
Casing width <b>T</b>	mm	330				350			
Inverter Power <b>EC</b>	V	3	5	7	10	3	5	7	10
Air flow <b>QV</b>	m <sup>3</sup> /h	179	323	432	442	360	515	625	830
<b>Heating: ΔTm 50,0 K - 75/65 °C</b>	W	2079	3655	4890	5247	3767	5134	6471	8415
<b>Heating: ΔTm 30,0 K - 55/45 °C</b>	W	1240	2180	2917	3129	2247	3062	3859	5019
<b>Heating: ΔTm 22,5 K - 45/40 °C</b>	W	935	1643	2199	2359	1694	2309	2910	3784
Sound power <b>L<sup>w</sup></b>	dB(A)	32	39	50	55	41	47	53	63
Sound pressure <b>LP(*)</b>	dB(A)	23	30	41	46	32	38	44	54
Weight <b>M</b>	kg	30,46				34,80			

(\*) = The sound pressure levels are 9 dB(A) lower than the sound power levels and apply to the reverberant field of a 100 m<sup>3</sup> room and a reverberation time of 0.5 sec.

## Technical data

### Casing length 2000 mm - Casing height 130/175 mm

#### 4 pipe units

The following standard rating conditions in accordance with the EN 16430 are used:

#### COOLING (summer mode)

Entering air temperature + 27 °C d.b.

Relative humidity 50%

Model		CFP-ECM 4T 2000-130-330				CFP-ECM 4T 2000-175-350				
Casing length <b>L</b>	mm	2000				2000				
Casing width <b>T</b>	mm	330				350				
Inverter Power <b>EC</b>	V	3	5	7	10	3	5	7	10	
Air flow <b>QV</b>	m <sup>3</sup> /h	211	391	519	613	422	634	793	1050	
<b>Cooling: ΔTm 17,5 K - 7/12 °C</b>	(Total emission)	W	792	2096	2797	3217	1613	2473	2719	3482
	(Sensible emission)	W	523	1416	1897	2218	1174	1913	2418	3482
<b>Cooling: ΔTm 12,5 K - 12/17 °C</b>	(Total emission)	W	467	977	1386	1740	939	1410	1844	2333
	(Sensible emission)	W	431	977	1386	1740	939	1410	1844	2333
<b>Cooling: ΔTm 10,0 K - 16/18 °C</b>	(Total emission)	W	382	773	1096	1355	835	1403	1886	2461
	(Sensible emission)	W	382	773	1096	1355	835	1403	1886	2461
Sound power <b>L<sup>w</sup></b>	dB(A)	32	40	51	59	39	45	51	62	
Sound pressure <b>L<sup>p</sup>(*)</b>	dB(A)	23	31	42	50	30	36	42	53	
Weight <b>M</b>	kg	35,7				40,5				

#### HEATING (winter mode)

Entering air temperature + 20°C

Modello		CFP-ECM 4T 2000-130-330				CFP-ECM 4T 2000-175-350			
Casing length <b>L</b>	mm	2000				2000			
Casing width <b>T</b>	mm	330				350			
Inverter Power <b>EC</b>	V	3	5	7	10	3	5	7	10
Air flow <b>QV</b>	m <sup>3</sup> /h	211	391	519	613	422	634	793	1050
<b>Heating: ΔTm 50,0 K - 75/65 °C</b>	W	2407	4282	6071	7562	4809	6554	8260	10742
<b>Heating: ΔTm 30,0 K - 55/45 °C</b>	W	1435	2554	3621	4510	2868	3909	4926	6407
<b>Heating: ΔTm 22,5 K - 45/40 °C</b>	W	1082	1926	2730	3400	2162	2947	3714	4830
Sound power <b>L<sup>w</sup></b>	dB(A)	32	40	51	59	39	45	51	62
Sound pressure <b>L<sup>p</sup>(*)</b>	dB(A)	23	31	42	50	30	36	42	53
Weight <b>M</b>	kg	35,7				40,5			

(\*) = The sound pressure levels are 9 dB(A) lower than the sound power levels and apply to the reverberant field of a 100 m<sup>3</sup> room and a reverberation time of 0.5 sec.

## Technical data

### Casing length 2500 mm - Casing height 130/175 mm

#### 4 pipe units

The following standard rating conditions in accordance with the EN 16430 are used:

#### COOLING (summer mode)

Entering air temperature + 27 °C d.b.

Relative humidity 50%

Model		CFP-ECM 4T 2500-130-330				CFP-ECM 4T 2500-175-350				
Casing length <b>L</b>	mm	2500				2500				
Casing width <b>T</b>	mm	330				350				
Inverter Power <b>EC</b>	V	3	5	7	10	3	5	7	10	
Air flow <b>QV</b>	m <sup>3</sup> /h	284	539	697	738	530	806	1009	1351	
<b>Cooling: ΔTm 17,5 K - 7/12 °C</b>	(Total emission)	W	1065	2888	3753	3872	2027	3143	3458	4482
	(Sensible emission)	W	704	1950	2545	2670	1475	2431	3075	4482
<b>Cooling: ΔTm 12,5 K - 12/17 °C</b>	(Total emission)	W	628	1346	1859	2094	1179	1792	2346	3003
	(Sensible emission)	W	580	1346	1859	2094	1179	1792	2346	3003
<b>Cooling: ΔTm 10,0 K - 16/18 °C</b>	(Total emission)	W	514	1065	1471	1631	1048	1783	2399	3168
	(Sensible emission)	W	514	1065	1471	1631	1048	1783	2399	3168
Sound power <b>L<sup>w</sup></b>	dB(A)	33	41	52	58	35	42	49	60	
Sound pressure <b>LP(*)</b>	dB(A)	24	32	43	49	26	33	40	51	
Weight <b>M</b>	kg	44,56				49,04				

#### HEATING (winter mode)

Entering air temperature + 20°C

Modello		CFP-ECM 4T 2500-130-330				CFP-ECM 4T 2500-175-350			
Casing length <b>L</b>	mm	2500				2500			
Casing width <b>T</b>	mm	330				350			
Inverter Power <b>EC</b>	V	3	5	7	10	3	5	7	10
Air flow <b>QV</b>	m <sup>3</sup> /h	284	539	697	738	530	806	1009	1351
<b>Heating: ΔTm 50,0 K - 75/65 °C</b>	W	3243	5847	8207	9425	6198	8447	10646	13844
<b>Heating: ΔTm 30,0 K - 55/45 °C</b>	W	1934	3487	4895	5621	3696	5038	6349	8257
<b>Heating: ΔTm 22,5 K - 45/40 °C</b>	W	1458	2629	3690	4238	2787	3798	4787	6225
Sound power <b>L<sup>w</sup></b>	dB(A)	33	41	52	58	35	42	49	60
Sound pressure <b>LP(*)</b>	dB(A)	24	32	43	49	26	33	40	51
Weight <b>M</b>	kg	44,56				49,04			

(\*) = The sound pressure levels are 9 dB(A) lower than the sound power levels and apply to the reverberant field of a 100 m<sup>3</sup> room and a reverberation time of 0.5 sec.



## Technical data

### Casing length 3000 mm - Casing height 130/175 mm

#### 4 pipe units

The following standard rating conditions in accordance with the EN 16430 are used:

#### COOLING (summer mode)

Entering air temperature + 27 °C d.b.

Relative humidity 50%

Model		CFP-ECM 4T 3000-130-330				CFP-ECM 4T 3000-175-350				
Casing length <b>L</b>	mm	3000				3000				
Casing width <b>T</b>	mm	330				350				
Inverter Power <b>EC</b>	V	3	5	7	10	3	5	7	10	
Air flow <b>QV</b>	m <sup>3</sup> /h	365	693	810	855	721	1098	1373	1840	
<b>Cooling: ΔTm 17,5 K - 7/12 °C</b>	(Total emission)	W	1370	3710	4488	4604	2754	4279	4708	6104
	(Sensible emission)	W	905	2506	3094	3122	2004	3310	4187	6104
<b>Cooling: ΔTm 12,5 K - 12/17 °C</b>	(Total emission)	W	807	1729	2281	2427	1602	2440	3194	4091
	(Sensible emission)	W	746	1729	2281	2427	1602	2440	3194	4091
<b>Cooling: ΔTm 10,0 K - 16/18 °C</b>	(Total emission)	W	661	1369	1804	1891	1425	2427	3266	4315
	(Sensible emission)	W	661	1369	1804	1891	1425	2427	3266	4315
Sound power <b>L<sup>w</sup></b>	dB(A)	33	41	52	57	36	43	49	60	
Sound pressure <b>L<sup>p</sup>(*)</b>	dB(A)	24	32	43	48	27	34	40	51	
Weight <b>M</b>	kg	53,74				62,6				

#### HEATING (winter mode)

Entering air temperature + 20°C

Modello		CFP-ECM 4T 3000-130-330				CFP-ECM 4T 3000-175-350			
Casing length <b>L</b>	mm	3000				3000			
Casing width <b>T</b>	mm	330				350			
Inverter Power <b>EC</b>	V	3	5	7	10	3	5	7	10
Air flow <b>QV</b>	m <sup>3</sup> /h	365	693	810	855	721	1098	1373	1840
<b>Heating: ΔTm 50,0 K - 75/65 °C</b>	W	4007	7286	9908	10898	8349	11378	14341	18650
<b>Heating: ΔTm 30,0 K - 55/45 °C</b>	W	2390	4345	5909	6500	4979	6786	8553	11123
<b>Heating: ΔTm 22,5 K - 45/40 °C</b>	W	1802	3276	4455	4900	3754	5116	6448	8386
Sound power <b>L<sup>w</sup></b>	dB(A)	33	41	52	57	36	43	49	60
Sound pressure <b>L<sup>p</sup>(*)</b>	dB(A)	24	32	43	48	27	34	40	51
Weight <b>M</b>	kg	53,74				62,6			

(\*) = The sound pressure levels are 9 dB(A) lower than the sound power levels and apply to the reverberant field of a 100 m<sup>3</sup> room and a reverberation time of 0.5 sec.

## Pressure drop

Height 130 mm - Length 330 mm

Heating

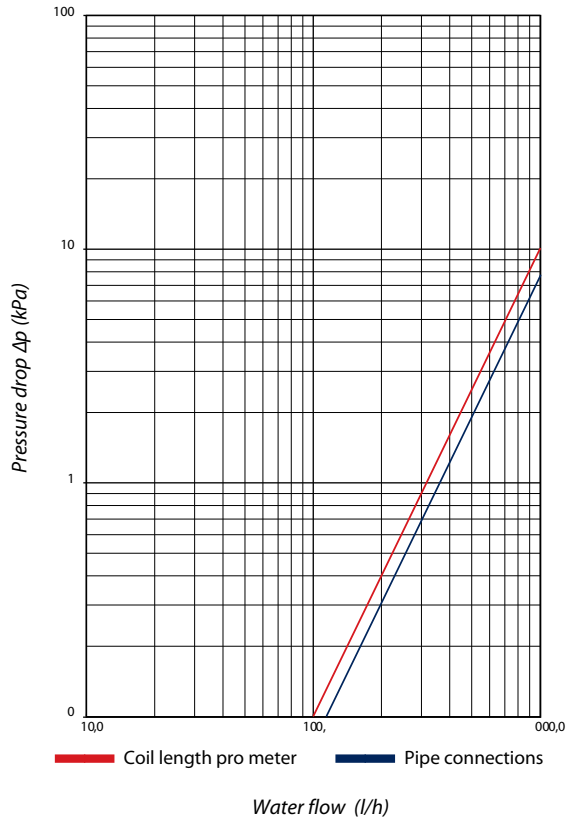

Cooling

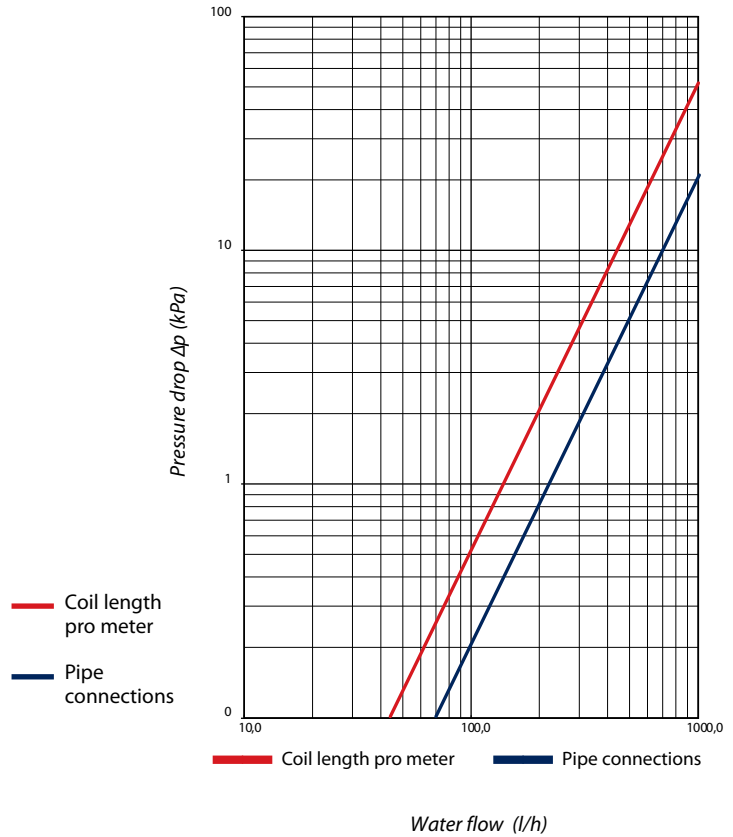

Height 175 mm - Length 350 mm

Heating

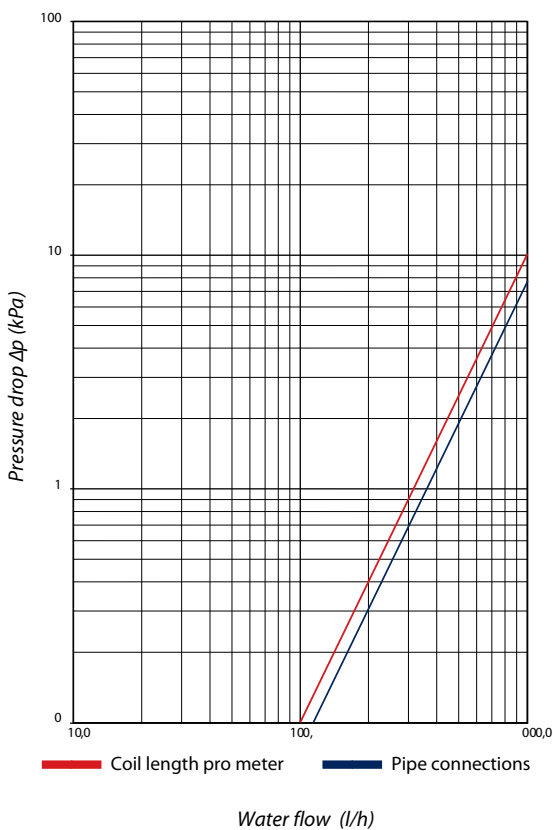

Cooling

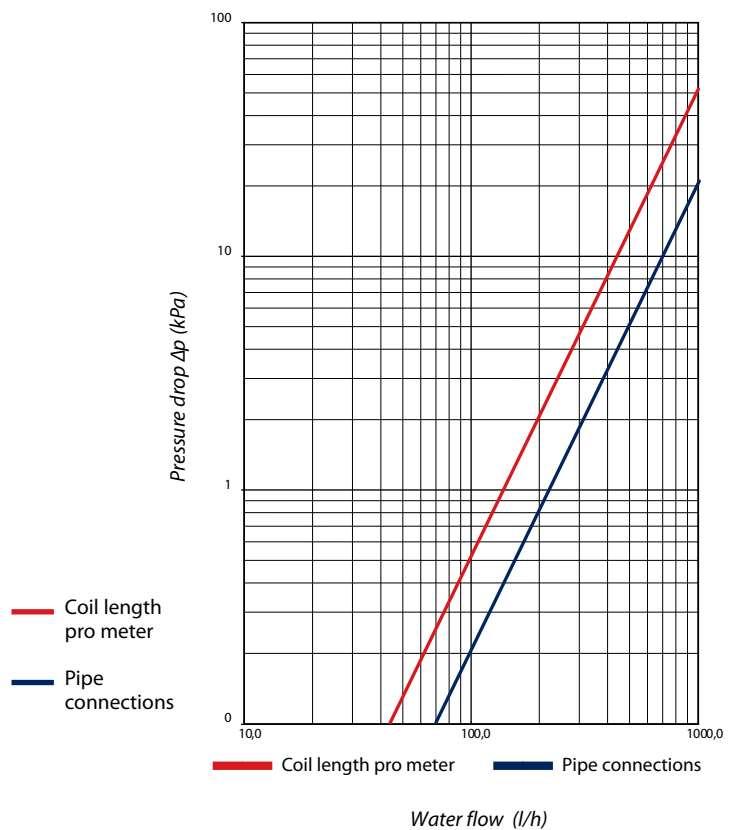

**Sabiana fan coil unit** can be equipped with a regulating valve to perform precise calibration for small amounts of water. The following graph shows the setting values.

Adjustment curves for valve inserts															
Pre-Setting	1	1,5	2	2,5	3	3,5	4	4,5	5	5,5	6	6,5	7	7,56	8
K <sub>VS</sub> Value Up To	0,16	0,21	0,24	0,30	0,34	0,41	0,44	0,54	0,65	0,82	0,98	1,11	1,23	1,33	1,43

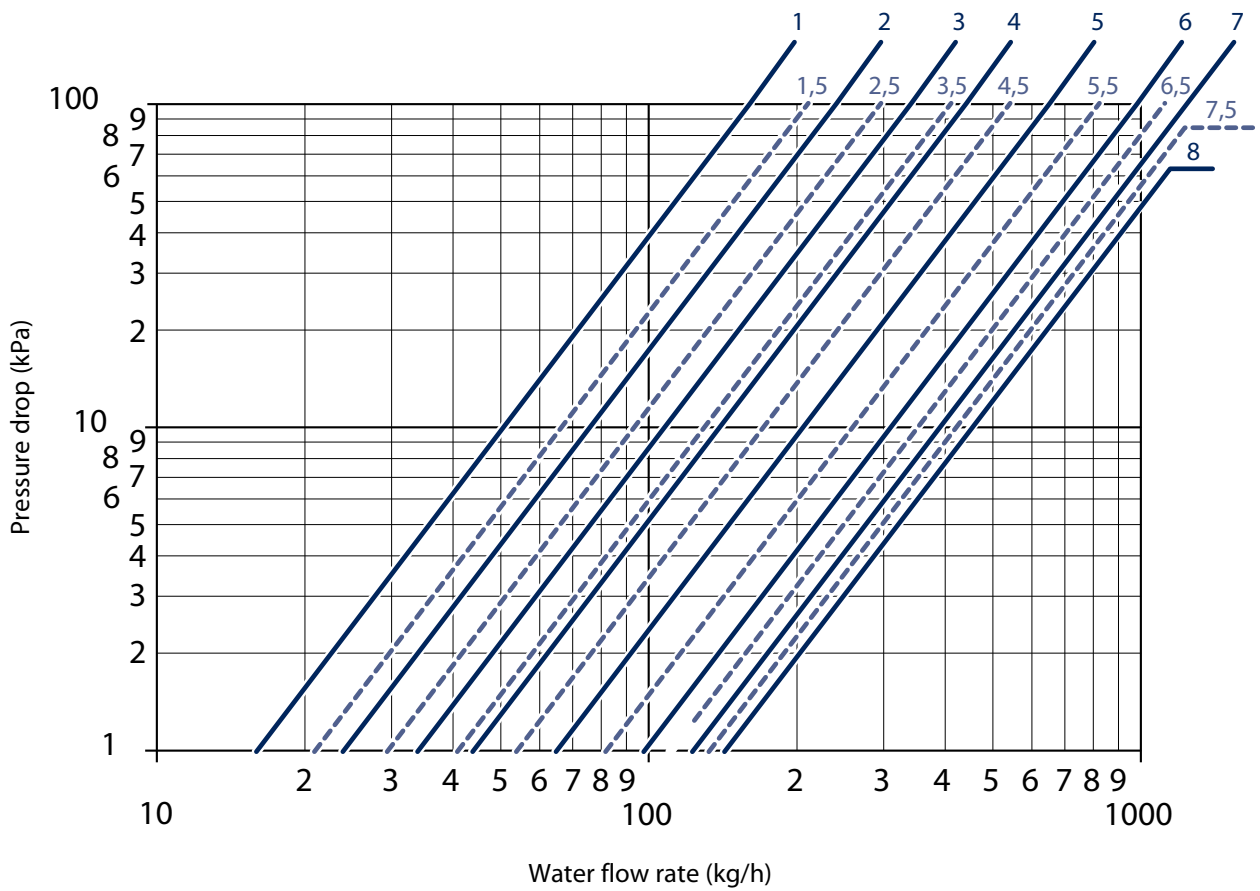

ATTENTION: the valves must be calibrated during installation according to the designed water flow rate.

**2-way modulating valve with actuator 24V (VE 8 (blue type),  $k_{VS}$  value 1,43)****Front connection valve**

- Lower valve body with  $k_v$  factory preset:
  - DN 15 external thread with euroconus  $\frac{3}{4}$ "
  - M30 x 1,5
  - Galvanised, protective cap.
- Adjustable return lockshield:
  - DN 15 external thread with euroconus  $\frac{3}{4}$ "
  - Galvanised.
- Thermoelectric actuator 24 V
  - Power supply: 24 V DC.
  - Control signal: 0-10V DC.
  - Absorption: 2 W.
  - Absorbed current: 80 mA.
  - Max inrush current.: 350 mA (max. 2 min).
  - Protection rating: IP 54.
  - Adjustment stroke: 4mm.
  - Including VA80 valve adaptor and 5m connection cable.
  - Normally closed in absence of current.



Version	Connection Type	Fitted		NOT Fitted	
		Identification	Code	Identification	Code
CFP-ECM 2T	A1 - A2	VM-A1-A2	9065225	VS-A1-A2	9065229
CFP-ECM 4T	A5 - A6	VM-A5-A6	9065227	VS-A5-A6	9065231

**Side connection valve**

- Lower valve body with  $k_v$  factory preset:
  - DN 15 external thread with euroconus  $\frac{3}{4}$ "
  - M30 x 1,5
  - Galvanised, protective cap.
- Adjustable return lockshield:
  - DN 15 external thread with euroconus  $\frac{3}{4}$ "
  - Galvanised.
- Thermoelectric actuator 24 V
  - Power supply: 24 V DC.
  - Control signal: 0-10V DC.
  - Absorption: 2 W.
  - Absorbed current: 80 mA.
  - Max inrush current.: 350 mA (max. 2 min).
  - Protection rating: IP 54.
  - Adjustment stroke: 4mm.
  - Including VA80 valve adaptor and 5m connection cable.
  - Normally closed in absence of current.



Version	Connection Type	Fitted		NOT Fitted	
		Identification	Code	Identification	Code
CFP-ECM 2T	A3 - A4	VM-A3-A4	9065226	VS-A3-A4	9065230

## ON-OFF 2-way valve not fitted, with actuator 230V (to be used with MB-CFP board only)

### Front connection A1-A2 valve

Consisting of:

- 2-way-angle and manual stop valve
  - Euroconus  $\frac{3}{4}$ " connections.
  - Valve body of brass.
- Thermoelectric actuator 230 V
  - Power supply: 230 V AC.
  - Absorption: 1,8 W.
  - Protection rating: IP 54.
  - Adjustment stroke: 2,5 mm.
  - Connection cable: 3 m.
  - Normally closed in absence of current.



Version	Connection Type	NOT Fitted	
		Identification	Code
CFP-ECM 2T	A1 - A2	VS-A1-A2-OF	9065118
CFP-ECM 4T	A5 - A6(*)		

(\*) for 4 pipe units, A5-A6 consider this code twice.

### Side connection A3-A4 valve

Consisting of:

- Straight 2-way and stop valve
  - Euroconus  $\frac{3}{4}$ " connections.
  - Valve body of brass.
- Thermoelectric actuator 230 V
  - Power supply: 230 V AC.
  - Absorption: 1,8 W.
  - Protection rating: IP 54.
  - Adjustment stroke: 2,5 mm.
  - Connection cable: 3 m.
  - Normally closed in absence of current.



Version	Connection Type	NOT Fitted	
		Identification	Code
CFP-ECM 2T	A3 - A4	VS-A3-A4-OF	9065117
CFP-ECM 4T			

## Cover grid

### Aluminium roll-up grid

Elegant, stable and sturdy, it can fit into the architectural design with great versatility. You may choose from different profiles, materials, colours and finishes.

To facilitate maintenance, the grid is easy to remove and then to be put back in place.

#### Dimensions:

- Length up to 3000 mm
- Height: 20 mm
- Slat width: 6 mm
- Slat distance: 14 mm
  - other distances on demand
- Free section: 70%

#### Treatment:

- Anodisation, natural or colour, powder painting in RAL colours.
- Colours for anodisation:
  - Natural
  - Bronze
  - Dark silver
  - Brass
  - Black
- Cutting surfaces in aluminium colour for grid in two sections.

#### Material:

- Aluminium profiles.

Width T mm	Description	Identification	Code
330	Natural anodised - standard	GAA 33-NAT	9065020
	Bronze colour anodised	GAA 33-BRO	9065021
	Dark silver colour anodised	GAA 33-ARG	9065022
	Brass colour anodised	GAA 33-OTT	9065023
	Black colour anodised	GAA 33-NER	9065024
	Optional colour anodised	GAA 33-COL	9065025
350	Natural anodised - standard	GAA 35-NAT	9065265
	Bronze colour anodised	GAA 35-BRO	9065266
	Dark silver colour anodised	GAA 35-ARG	9065267
	Brass colour anodised	GAA 35-OTT	9065268
	Black colour anodised	GAA 35-NER	9065269
	Optional colour anodised	GAA 35-COL	9065270

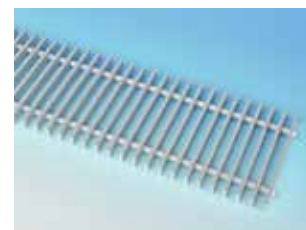

Natural anodised  
(standard)



Bronze



Dark silver

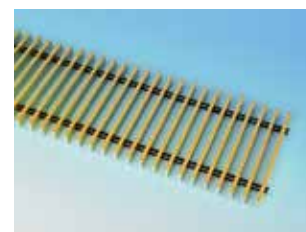

Brass



Black

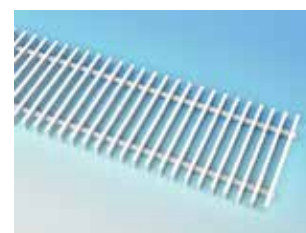

Powder painting  
in RAL colours



## Cover grid

### Stainless steel grid

Elegant, stable and sturdy, it can fit into the architectural design with great versatility. You may choose from different profiles, materials, colours and finishes.

To facilitate maintenance, the grid is easy to remove and then to be put back in place.

#### Dimensions:

- Length up to 3000 mm
- Height: 20 mm
- Slat width: 10 mm
- Slat distance: 16 mm
- Free section: 60%

Width T mm	Identification	Code
330	GAI 33	9065037
350	GAI 35	9065075



Stainless steel

### Wooden grid

Elegant, stable and sturdy, it can fit into the architectural design with great versatility. You may choose from different profiles, materials, colours and finishes.

To facilitate maintenance, the grid is easy to remove and then to be put back in place.

#### Dimensions:

- Length up to 3000 mm
- Height: 20 mm
- Slat width: 12 mm
- Slat distance: 16 mm
- Free section: 55%

Width T mm	Colore	Identification	Code
330	oak colour	GLE 33-QUE	9065073
	ash colour	GLE 33-FRA	9065074
	beech colour	GLE 33-FAG	9065075
350	oak colour	GLE 35-QUE	9065280
	ash colour	GLE 35-FRA	9065281
	beech colour	GLE 35-FAG	9065282



## Cover grid

### Aluminium linear grid

Elegant, stable and sturdy, it can fit into the architectural design with great versatility. You may choose from different profiles, materials, colours and finishes. To facilitate maintenance, the grid is easy to remove and then to be put back in place.

#### Dimensions:

- Length up to 3000 mm
- Height: 20 mm
- Slat width: 6 mm
- Slat distance: 10 mm
- Free section: 60%

#### Treatment:

- Anodisation, natural or colour, powder painting in RAL colours.
- Colours for anodisation:
  - Natural
  - Bronze
  - Dark silver
  - Brass
  - Black
- Cutting surfaces in aluminium colour for grid in two sections.

#### Construction:

- Vertical profile slats, very rigid thanks to press-forming on angular aluminium profiles connected at a distance of 200-300 mm.

#### Material:

- Aluminium profiles.

Width T mm	Description	Identification	Code
330	Natural anodised - standard	GLA 33-NAT	9065050
	Bronze colour anodised	GLA 33-BRO	9065051
	Dark silver colour anodised	GLA 33-ARG	9065052
	Brass colour anodised	GLA 33-OTT	9065053
	Black colour anodised	GLA 33-NER	9065054
	Optional colour anodised	GLA 33-COL	9065055
350	Natural anodised - standard	GLA 35-NAT	9065283
	Bronze colour anodised	GLA 35-BRO	9065284
	Dark silver colour anodised	GLA 35-ARG	9065285
	Brass colour anodised	GLA 35-OTT	9065286
	Black colour anodised	GLA 35-NER	9065287
	Optional colour anodised	GLA 35-COL	9065288



Natural anodised  
(standard)



Bronze

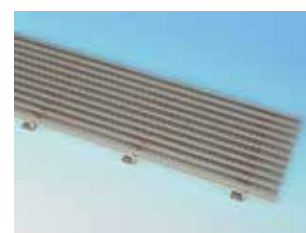

Dark silver



Brass



Black



Powder painting  
in RAL colours

## Accessories and auxiliary products for assembly

### Air intake filter

Intake filter PPI 30 dark 140 x 3 mm.



Version	Width T mm	Identification	Code
CFP-ECM 2T CFP-ECM 4T	900	FVM-90	9065290
	1000	FVM-100	9065106
	1200	FVM-120	9065291
	1400	FVM-140	9065292
	1700	FVM-170	9065293
	2000	FVM-300	9065122

Version	Width T mm	Identification	Code
CFP-ECM 2T CFP-ECM 4T	2500	FVM-200	9065294
	3000	FVM-250	9065295

### Empty casing

The range and minimum and special lengths of the casings vary for the different models.

**Dimensions:**

- Variable lengths: 200–3000 mm

**Material:**

- Galvanised steel painted Anthracite grey (RAL 7016 opaque) with natural anodised aluminium casing.

You must specify the length of the casing when placing the order.



Height H mm	Width T mm	Identification	Code
130	330	CVSG 13-33	9065101
175	350	CVSG 17-35	9065262

### Casing fastening and installation

**Fastening with adjustable feet.**

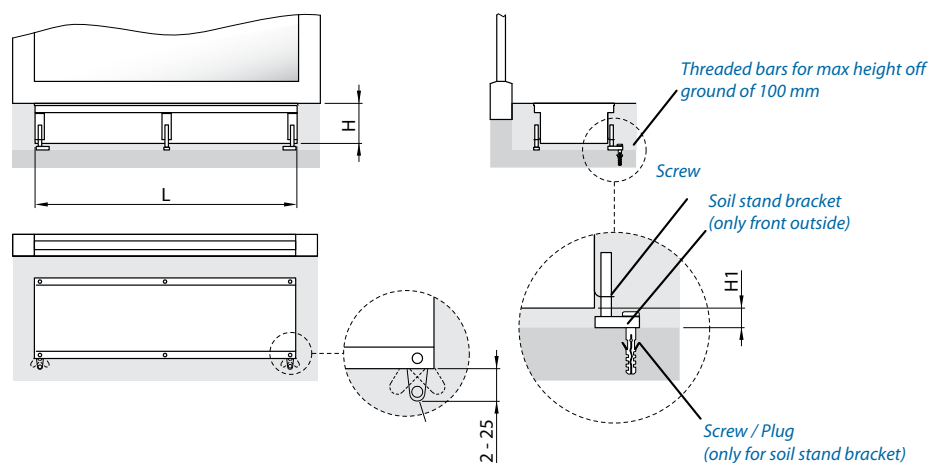

Version	Height H mm	H1
CFP-ECM 2T CFP-ECM 4T	130	3 - 50
	175	3 - 85

**Number of feet depending on length**

Version	Length L mm	Number of assembly brackets
CFP-ECM 2T 130x330	750 - 1340	2
	1341 - 2200	3
	2201 - 3000	4
CFP-ECM 4T 130x330	850 - 1440	2
	1441 - 2300	3
	2301 - 3000	4
CFP-ECM 2T 175x350	900 - 1300	2
	1301 - 2500	3
	2501 - 3000	4
CFP-ECM 4T 175x350	1000 - 1400	2
	1401 - 2600	3
	2601 - 3000	4

## Casing sound absorbtion lining

4 mm sound absorbtion lining installed in the factory on the outer surface of the casing.

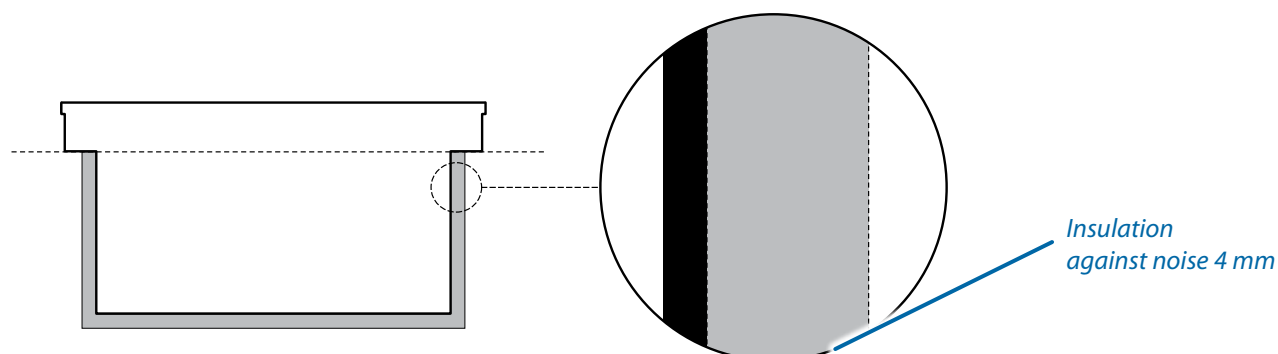

Dimension mm	Identification	Code
48x900	TS-90	9065300
48x1000	TS-100	9065107
48x1200	TS-120	9065301
48x1400	TS-140	9065302
48x1700	TS-170	9065303
48x2000	TS-200	9065242
48x2500	TS-250	9065304
48x3000	TS-300	9065305

## Air connections with dampers for flow rate adjustment

Connection Dimensions	Identification	Code
63	LAG63	9065108
80	LAG80	9065109

One or more connections can be supplied for fresh air equipped with adjustment damper. The connections can only be supplied on empty casings. Their position can be defined on demand.

(1) = The positioning of air connections is only affected minimally by the position of the transversal ribs of the floor casing. For example: F connection (in the middle environment side) = "about halfway" The exact position/dimension can be found on the drawing and must be approved by the customer.

## Number and position of air connections

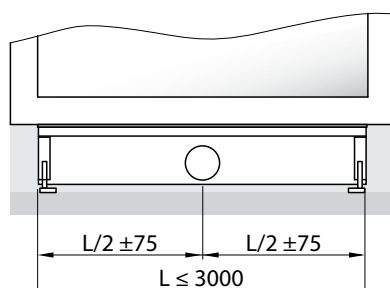

## Condensate pump

Completely automatic pump for condensate discharge, in case of impossible drainage under gravity.

**Technical data:**

- Motor absorption = 11 Watt
- Voltage 230 V – 50 Hz
- Max. flow rate: 12 l/h
- Available static pressure: 10 m
- Max. fluid temperature: 50° C
- System weight: 1.1kg
- Connection cable, length 2.0 m.



<b>Version</b>	CFP-ECM 2T / CFP-ECM 4T
<b>Identification</b>	PC-FL
<b>Code</b>	9065112

## Soil stand brackets

Version	Description	Identification	Code
CFP-ECM 2T CFP-ECM 4T	Central soil stand brackets	ST-FL	9065110
	Pair of lateral soil stand brackets	CST-FL	9065111

The kit number changes according to the length of the bought units; for the number to order, see the following table:

Length L (mm)	Central soil stand brackets	A couple of side soil stand brackets
	9065110	9065111
900 - 1000 - 1200	0	1
1400 - 1700 - 2000 - 2500	1	1
3000	2	1

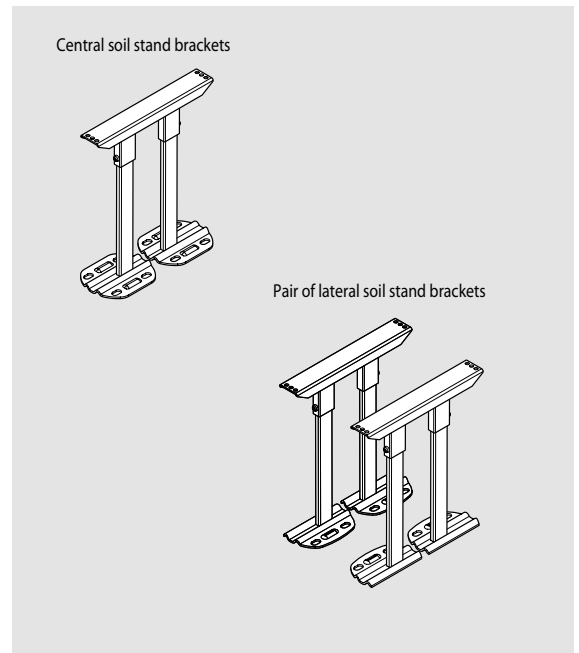

The SRM regulation board can be used with all Carisma Floor Fan coil units by Sabiana, that are equipped with tangential fan (**CFP-ECM 2T** e **CFP-ECM 4T**) and it is pre-mounted in factory with protection class IP65 package. All the integrated electrical components are already wired and ready for connection.

The system can be at any time equipped with a range of different inputs/outputs (plug-in), in accordance with the client needs.

## Electrical connection

The floor trench convector must be connected to the ambient thermostat and to the power line. This connection is made on two different lines and carried out as follows:

- the thermostat is connected to the circuit board of the unit by means of a 0.25 mm<sup>2</sup> cross-section twisted pair cable with a maximum allowed length of 30 m;
- the circuit board must have a 220-240V AC power supply, by means of a conductor with a minimum cross-section of 1,5mm<sup>2</sup>.

Furthermore, based on the configuration and supply of optional control components, it may be necessary to make the following external connections:

- internal bus line towards other fan coil unit in an integrated control system (up to 6 fan coil units), min cable cross-section 0.25 mm<sup>2</sup>, max line length 100 m;
- bus line connecting to a centralised home automation management system of the entire building (BMS), min cable cross-section 0.25 mm<sup>2</sup>, max line length 700 m between Sabiana with KNX board and an IP router;
- connection cable with an outdoor temperature sensor;
- connection cable of a transmission receiver (for reception of input signals from contact detectors for windows and presence sensors).

The following optional control components are wired inside the floor duct.

They can be connected in the factory (according to the specific order) or at the worksite by the installer:

- thermoelectric actuator 24 V DC, control voltage 0-10 V DC;
- inlet temperature detection probe (in **CFP-ECM 4T** version, for heating and cooling circuit);
- dew point sensor (**CFP-ECM 2T** and **CFP-ECM 4T**);
- KNX board.

Per maggiori informazioni sul collegamento elettrico, consultare il manuale di installazione elettrica.

## Commissioning

All Sabiana fan coil units are supplied with default control parameters.

According to the type of use (e.g. control with or without connection to a home automation management system of the building), to the trench convector model and to specific compartments of the user, upon commissioning, it could be necessary to set the parameters of the control system, using a Sabiana ambient thermostat (see accessory TAD - Code 9065080).



## Features of the control system / Overview of the functions

- Automatic fan speed control depending on the heating demand of the environment (difference between set temperature and actual temperature).
- Synchronous control of fan speed and valve stroke (water flow) for a balanced hydraulic network and high energy efficiency operation (respecting a minimum difference between supply and return temperature).  
According to a preliminary study conducted by Prof. Dr. Rainer Hirschberg, of the Technical University of Aachen (Hochschule Aachen), up to 8% thermal energy and beyond 80% electrical energy can be saved with respect to traditional systems without synchronous control.

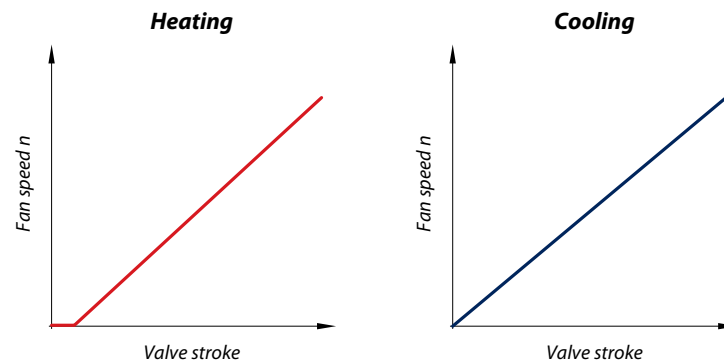

- Quick automatic heating with outdoor temperature in the thermal comfort range ( $\pm 0.5$  °C of the nominal temperature) - can be deactivated with the parameter.
- Possibility of setting a maximum speed limit of the fan within the thermal comfort range.
- "Quiet heating" (without ventilation) for low power outputs.
- Antifreeze function with ambient temperature sensor.
- Possibility of connection to a central home automation management system of the building by means of an optional KNX board (a single board per integrated control group).

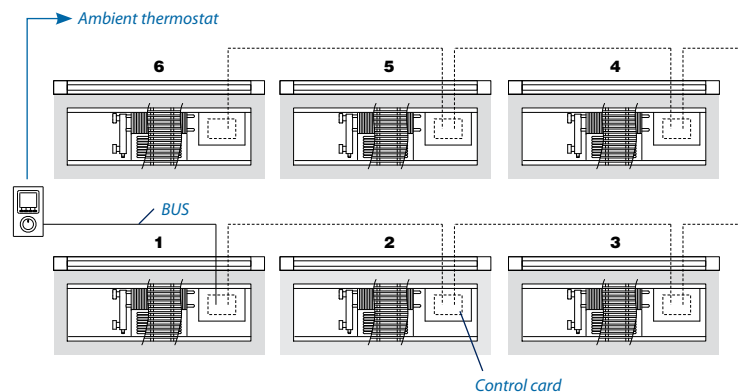

- Even if controlled by a central home automation system (BMS), control parameters can be adapted to individual requirements using a connected ambient thermostat (e.g. changing the nominal temperature for a limited time interval).
- Possibility of controlling up to 6 fan coil units (integrated group) with an ambient thermostat.
- Inside an integrated system, possibility of control with different ambient temperatures (detected by outdoor ambient temperature probes – optional accessory).
- For even greater energy efficiency, possibility of integrating further optional accessories in the control system, such as contact detectors for windows and presence sensors (both wireless).
- Automatic change-over in 2 pipe system by installing inlet water temperature sensors (accessories).

## Management system with TAD digital ambient thermostat

- The wall control of the Sabiana control system is equipped with a large multifunction display and functional input elements for the utmost practicality (see the pages "Controls and Accessories").

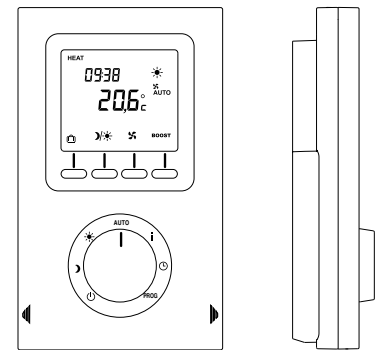
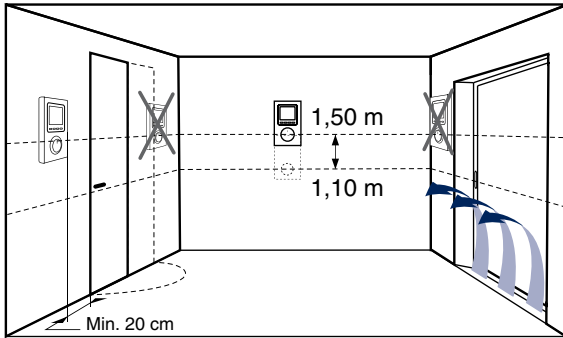

## Product features

- Management by navigation knob and function keys
- Multifunction LCD display with automatic backlighting (light blue)
- Individually settable timing programs
- Integrated ambient temperature sensor
- Supply voltage by bus connection to control card
- Real time clock
- Customisable basic information
- BOOSTER function
- Holiday function
- Signalling by icons, possibility of international use
- Possibility of wall mounting
- Plastic case, colour similar to RAL 9010
- Technical data:
  - Supply voltage by bus connection to control card, 12-28V
  - Protection class II
  - Dimensions L x H x D = 81 x 135 x 33 mm
  - Protection rating IP 30
  - Timer data storage in case of power interruption: 2 hours
  - Operating temperature: from 0 °C to + 40 °C (10% - 90% relative humidity of air)
  - Suitable for wall mounting
  - Plastic case, colour similar to RAL 9010.

## Icons key

- HEAT** Heating
- COOL** Cooling
- ☀ Comfort mode
- ☾ Economy mode
- ❄ Antifreeze mode
- ⏻ OFF
- 🌀 Fan
- 👤 Manual control
- 📅 Absence
- BOOST** Quick heating/cooling
- ⚠ Error (see i mode)
- 🚪 Opening detection
- ⌫ Cancel
- 💻 BMS System  
(central home automation management) connected

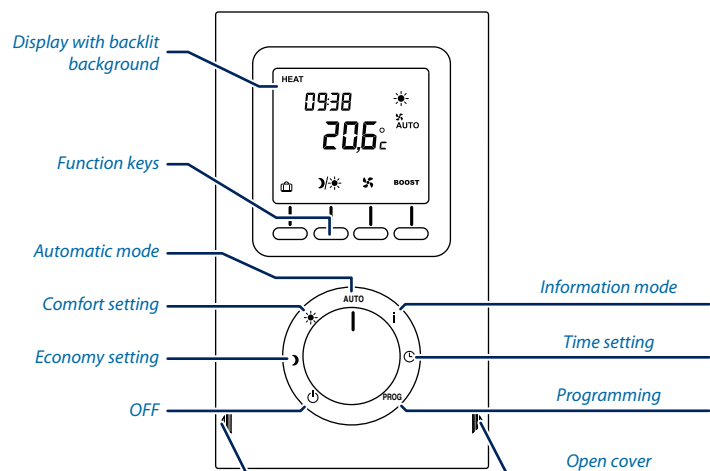

## Functions

<b>Command:</b>	Control parameters input (for example nominal temperatures) Command by selection menu and function keys
<b>Visualisation:</b>	Visualisation of parameters and system status
<b>Temperature measurement:</b>	Ambient temperature detected by means of built-in temperature sensor
<b>Timing programs:</b>	Timing programs settable individually Possibility of setting various daytime switch-on values between economy mode and comfort mode
<b>Error management:</b>	Display of errors in INFO mode
<b>Shortcut keys:</b>	Quick access to manual control functions in AUTO mode by means of function keys
<b>Manual fan management:</b>	In 4 stages (0 - 1 - 2 - 3) with preset fan speed for time interval setting
<b>Manual mode selection:</b>	Switching from economy to comfort per time interval setting
<b>BOOSTER (manual):</b>	Quick heating for a certain time interval (15-30-60 min)
<b>Holiday function:</b>	Antifreeze mode for a freely settable number of days (1-365)
<b>Integrated groups control:</b>	Possibility of controlling an integrated group of up to 6 Sabiana fan coil units with an ambient thermostat
<b>Customised settings:</b>	Of the control parameters of a BMS system (for example nominal temperatures, operating mode) for a limited time interval

## Controls and Accessories

### Digital ambient thermostat

- Programmable ambient thermostat, including fan control.
- Control for temperature adjustment, including fan control, with large LCD display to control up to 6 fan coil units.
- Automatic energy-saving light blue backlighting.
- Configurable timing program.
- Temperature range from 9 °C to 32 °C.
- Adjustment step 0,5 °C.
- Antifreeze temperature 8 °C.
- Adjustable thermal deviation +/-5 °C.
- Heating/cooling control.
- Power supply via BUS cable.
- 5A relay output.
- Protection rating/class: IP30 / II
- Plastic case 81x135x22 for wall mounting.
- Colour similar to RAL 9010.



<b>Version</b>	<b>CFP-ECM 2T / CFP-ECM 4T</b>
<b>Identification</b>	TAD
<b>Code</b>	9065080

### SRM regulation and control board (It must be used with TAD digital ambient thermostat)

For the functions of SRM regulation board with TAD thermostat see the pages "Regulation System".

<b>Version</b>	<b>CFP-ECM 2T / CFP-ECM 4T</b>
<b>Identification</b>	SRM
<b>Code</b>	9065257



### Air temperature sensor

NTC 10 K ambient temperature sensor with plastic cap, including 3 m cable + installation material.

<b>Version</b>	<b>CFP-ECM 2T / CFP-ECM 4T</b>
<b>Identification</b>	STAR
<b>Code</b>	9065083



### Water temperature sensor

• To detect supply temperature, including 2 m cable + installation material, for lengths up to 2000 mm.

• To detect supply temperature, including 4 m cable + installation material, for lengths up to 2000 mm.

<b>Identification</b>	<b>STAC-2</b>
<b>Code</b>	9065084

<b>Identification</b>	<b>STAC-5</b>
<b>Code</b>	9065085



## Controls and Accessories

### Dew point detector

- 24 V DC power supply.
- Max absorbed current 3 mA.
- Application range: from 10% to 100% R.H.
- Including cable gland and board connector.

<b>Version</b>	CFP-ECM 2T / CFP-ECM 4T
<b>Identification</b>	LPR
<b>Code</b>	9065086



### Contact detector for windows (must be coupled to transmission receiver)

- Power supply: 1.3 V lithium battery type CR2032, lasts up to 2 years.
- Transmission type: X2D protocol.
- Transmission frequency 868 MHz.
- Signal coverage up to 300 m (in open field).
- Protection rating IP 40.
- ABS/PC case.

<b>Version</b>	CFP-ECM 2T / CFP-ECM 4T
<b>Identification</b>	LCF
<b>Code</b>	9065087



### Presence sensor (must be coupled to transmission receiver)

- 230 V power supply with phase and neutral.
- Transmission frequency 868 MHz.
- 1 - 2 channels depending on function.
- 3 pre-installed cables to connect switches, ON/OFF buttons.
- 1 wired phase inlet for detector or button.
- Up to 16 two-way receivers and an optional number of one-way receivers.
- Operating temperature: from -5 °C to 40 °C.
- Dimensions: H 50 x W 47 x D 23 mm.

<b>Version</b>	CFP-ECM 2T / CFP-ECM 4T
<b>Identification</b>	SPR
<b>Code</b>	9065088



### Transmission receiver

- For window contact detectors and presence sensors.
- Power supply by control card.
- Up to 2x20 recordable emitters.
- Signal coverage up to 100m (open field).
- Including 1m cable + installation material.

<b>Version</b>	CFP-ECM 2T / CFP-ECM 4T
<b>Identification</b>	RTR
<b>Code</b>	9065089



### 24VDC 4.2A power supply

- One single output 24 VDC 4.2A, protected by short-circuit and overcharge.
- Protection class IP 67.
- Dimensions : 190x52x37 mm.

<b>Version</b>	CFP-ECM 2T / CFP-ECM 4T
<b>Identification</b>	LPV-100-24
<b>Code</b>	3021507





The CFP-ECM units without MB board can be equipped with a wide range of controls that allow to manage one single unit or several units by using the **Modbus RTU - RS 485** communication protocol.

Units can be managed according to the Master/Slave logic (up to 20 units) or by supervisory components.

The system consists in a MB-CFP and a series of controls, such as the T-MB control and the PSM-DI multifunction control.

**Note:**

- The units must be ordered without electronic board (contact the Sabiana technical department).
- The MB-CFP board is available only not fitted.

---

### MB-CFP board

---

Description	Identification	Code
MB-CFP board, not fitted (power supply included)	MB-CFP	9065258

The MB-CFP electronic board is set to carry out different functions and adjustment modes, in order to meet the installation requirements.

These modes are selected by setting the configuration dip switches on the board.

- 2/4 pipe system.
- Fan ON/OFF thermostatic control.
- Valve ON/OFF thermostatic control and continuous ventilation.
- Valve and simultaneous ventilation ON/OFF thermostatic control.
- Fan operation control depending on the coil temperature (cut-out T3 probe fitted), which can be activated only in heating mode or heating and cooling mode.
- Automatic switch of the operating mode by means of T2 water probe (optional) applied on the 2 pipe system.
- Seasonal switch by means of remote contact.
- ON/OFF of the fan coil by means of the remote contact (window or clock contact).



By activating the cut-out T3 probe function, the fan is stopped in winter when the coil temperature is lower than 32 °C and started when the temperature reaches 36 °C. In summer mode, the fan stops when the temperature inside the coil exceeds 22 °C and starts when it drops below 18 °C.

The following connections are located on the power board:

- Receiver for infra-red remote control.
- T-MB control.
- RS 485 serial connection to manage several fan coils in Master/Slave configuration or to create a supervisory network.

NTC sensor included for T1 function (return air control).

NTC sensor included for T3 function (low temperature cut-out thermostat).

NTC sensor (option) for T2 function (summer/winter switch).

**T-MB wall control**

Description	Identification	Code
Wall control (to be used only with MB-CFP board)	T-MB	9066331E

Wall control with display that allows controlling one or more units in Master/Slave mode. The control is equipped with internal sensor to detect the room temperature, which can be defined as a priority compared to the return air sensor on the fan coil.

The T-MB control features the following functions:

- Switch the unit ON and OFF.
- Temperature set.
- Modify the set point (when used as a +/- 3° variation of the set point configured from Sabianet supervisory program or PSM-DI).
- Set the fan speed (low, medium, high or auto fan).
- Set the operation mode (fan only, cooling, heating; auto for 4 pipe systems with mode selection depending on the air temperature).
- Time setting.
- Weekly ON/OFF program.
- Display and change of the fan coil operation parameters.



Dimensioni: 110x72x25 mm

A group of Carisma CFP-ECM units with MB-CFP electronic board can be connected via a serial link and can consequently be managed at the same time by just one T-MB. Using the special jumper present on the MB board, one unit must be configured as the master, and all the others as slaves.

**With T-MB wall control**

**ONE CONTROL FOR MORE UNITS**  
(MAXIMUM TOTAL LENGTH OF THE CONNECTION CABL = 20 m)



**ONE CONTROL FOR MORE UNITS (20 UNITS MAX.)**  
(MAXIMUM TOTAL LENGTH OF THE CONNECTION CABL = 800 m)



**T2 accessory(Change-Over)**

The T2 sensor can be combined with MB-CFP board and without valves. NTC type sensor (can be used as Change-over) with units equipped with MB-CFP boards and to be placed on the water supply pipe.

The T2 sensor (Change-over) must be used as described below for 2-pipe system for the automatic switch of the operating mode. If water temperature is lower than 20 °C, cooling mode is set; on the other hand, if water temperature exceeds 30 °C, heating mode is set.

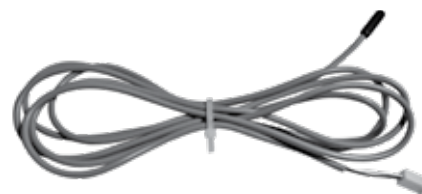

Identification	Code
T2	9025310

## PSM-DI multifunction control panel

Description	Identification	Code
PSM-DI multifunction control panel (to be used only with MB-CFP board)	PSM-DI	3021293

Another option available for the serial communication between the units is the possibility to connect up to 60 CFP-ECM units in series and manage them with just one wall mounted PSM-DI controller.

The wall mounted controller can be used to set the operating mode for each individual unit connected, display the operating conditions of each individual unit, and set the ON/OFF time sets for each day of the week (the program can be set for all the units and for a maximum of ten groups of units).

If more than 60 units need to be connected, two or more PSM-DI control panels must be used. Each unit must have a MB board.

The PSM-DI control is used to manage a series of fan coils, up to a maximum of 60 units (the maximum length of the RS 485 connection cable must not exceed 800 m), from one single control point.

The PSM-DI control communicates via a serial line with all the units connected, with the possibility of controlling them all together or individually. In fact, the unique address of each individual fan coil means that all the units can be called at the same time, or the individual unit called, to perform the following functions:

- display the current operating mode, the fan speed, the set point;
- display the room temperature measured on the individual unit;
- turn all the units ON and OFF at the same time or alternatively each unit individually;
- change the operating mode (fan only, heating, cooling, automatic changeover);
- change the set point;
- modify the values and operation parameters of the fan speed.

Each function can then be sent to all the units connected, or alternatively to each individual unit. Different set points or operating modes can be set for each individual unit. The PSM-DI panel can also be used for the time management of the units over the week. Four ON times and four OFF times can be set on the units for each day of the week.

A different temperature set that will be considered as Operation set for all connected appliances, can be set for each event. If the temperature set is not entered for the individual event, it must be set during programming for each individual unit or for the entire network.



### Nota:

- It is possible to connect only one single SIOS board per each PSM-DI control panel.
- The RS 485 network's overall length must not exceed 700/800 metres.

---

### T-DI - Touch screen multifunction control panel

---

The **T-DI** multifunction control panel lets supervise and control more units with MB or SIOS boards; the panel is equipped with a 7 inches touch screen display and a serie of graphical pages that allows an easy reading of the data sent by the fan coils and the management of up to 60 units (max. 60 units: SIOS + MB).

With the multifunction control panel **T-DI** it is also possible to control the units remotely with the specific **Sabiana Cloud** App for Android and iOS. The **Sabiana Cloud** APP is simple to use and lets have complete control of all the connected units.

#### Touch screen multifunction control panel



---

### SabWeb - Web gateway for Sabiana Cloud

---

With the Web gateway for "Sabiana Cloud" it is possible to control remotely up to 60 units, equipped with MB or SIOS boards (max. 60 units: SIOS + MB), with the specific APP for Android and iOS.

The "Sabiana Cloud" APP is simple to use and lets have complete control of all the connected units.

#### Web gateway for Sabiana Cloud



**Sabianet program for managing a network of Sabiana MB fan coils**

Description	Identification	Code
Hardware/software supervisory system (to be used with MB-CFP board only)	Sabianet	9079118

Sabianet is a centralised control system for networks of Sabiana MB fan coils, based on software that runs on LINUX™ operating system (the program is provided pre-installed on a PC) and it works in a "stand alone" way, as an ordinary computer, so that it can be connected to a monitor, to a mouse and to a keyboard. By connecting an Ethernet cable is instead possible to work at a distance and visualize the entire program setting-up through whatever browsers. The Sabianet software offers a practical and economical solution for managing the units, with the simple click of the mouse.

The main characteristics are:

- simplicity of use
- an extremely complete and functional weekly program
- possibility to access the historical operating data for each individual unit connected
- possibility of data saving on USB key
- visualization of the saved configuration on a new ASUS PC

The program can be used to:

- create uniform groups (groups of units on individual floors, in offices or rooms)
- save weekly programs configured for different types of operation (summer, winter, mid seasons, closing periods etc.); these can then be recalled and activated with a simple click of the mouse. Weekly on/off cycles can be set for individual units or groups of units
- set the operating conditions for each individual unit or groups of units (operating mode, fan speed, temperature setting)
- set the set point limits for each individual unit or groups of units
- switch each individual unit or groups of units On or OFF.

With Sabianet it is also possible to control the units from a distance with the specific Sabiana cloud APP for android and iOS.

The Sabiana cloud aPP is simple to use and lets have complete control of all the connected units.



**Graphical pages**

The main program screen can display and interact with the entire network of units. An individual unit, a group of units or the entire network can be called so as to make modifications to the operating mode and the set point.

The user can then check the operating status of each individual unit, read the room temperature, the coil temperature and the operating status of the condensate drain pumo or any alarms. The "Monitoring" Screen shows the units that are connected to the network and scanned by the program.



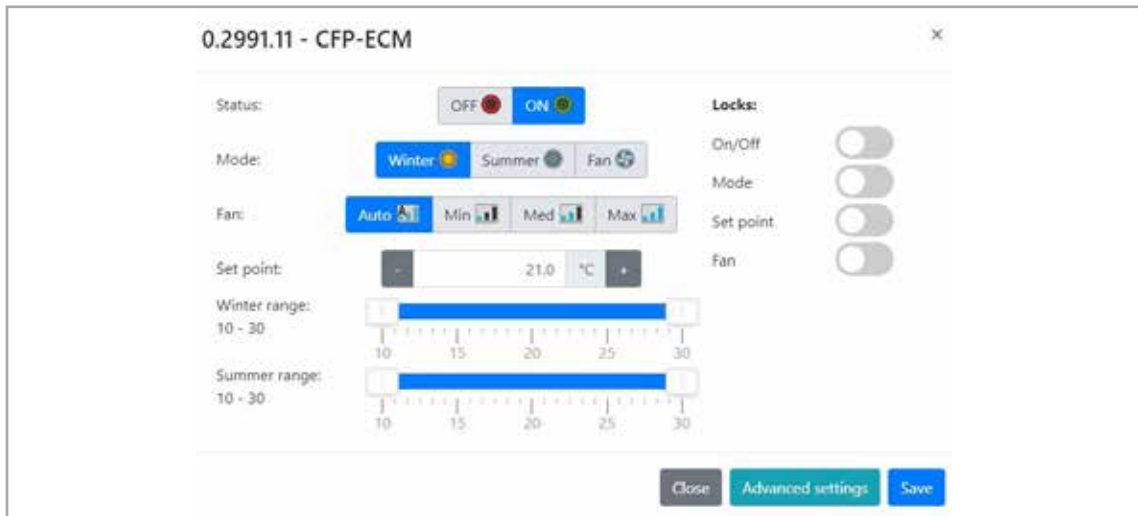

The icon of the terminal unit provides the following information:

- unit name (0.2991.11)
- set temperature (SETP)
- room temperature (AT)
- unit status:



ON



OFF

- Mode:



Summer



Winter



Auto



Fan only

- Fan speed:



Low



Medium



High



Auto Fan

The “**Programs**” Screen, can be used to set the unit operating parameters for each day of the week. Several weekly programs can be set. Time bands are available for each day of the week. The time and the type of operation to be performed by the unit can be set for each band. The time and the operating parameters can then be displayed before being sent to the unit and implemented.

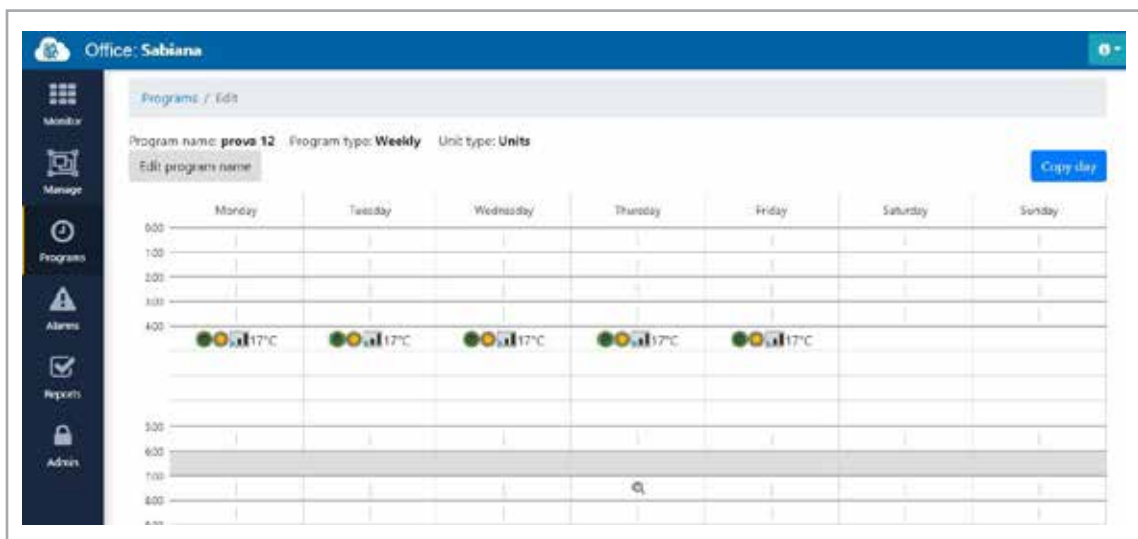



Every time that the reading of the set up Dip Switches results not easy (as for example by the false ceiling installations), it is always possible to display them directly through the Sabianet program.

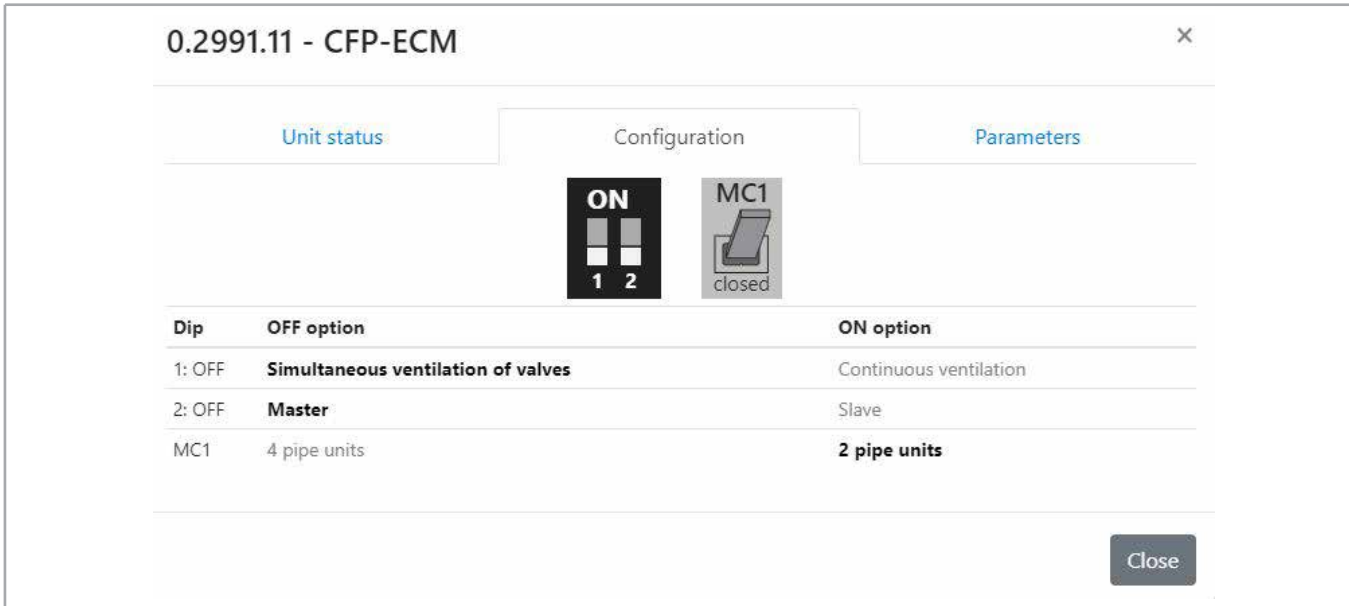

Dip	OFF option	ON option
1: OFF	<b>Simultaneous ventilation of valves</b>	Continuous ventilation
2: OFF	<b>Master</b>	Slave
MC1	4 pipe units	<b>2 pipe units</b>



Parameter	Value	Unit
T3 fan on heating	30.0	°C
T3 fan on cooling	22.0	°C
T3 fan control hysteresis	5.0	°C
Post-ventilation time	100	sec.
ECM voltage MIN speed	1.0	V
ECM voltage MED speed	5.0	V
ECM voltage MAX speed	10.0	V
T-MB probe offset	0.0	°C
T2 change-over ventilation --> cooling	15.0	°C
T2 change-over ventilation --> heating	30.0	°C

In addition to the "Alarms" set on the Sabianet display, it is possible to send the ON-OFF alarm notification via E-mail and sms.

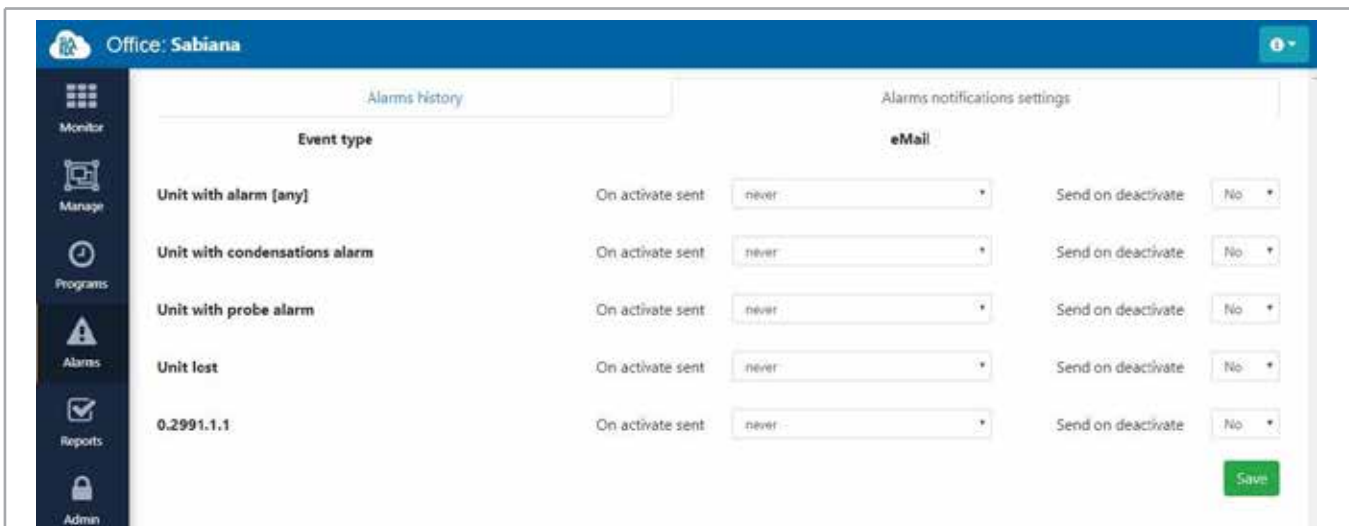

Event type	On activate sent	Send on deactivate
Unit with alarm [any]	never	No
Unit with condensations alarm	never	No
Unit with probe alarm	never	No
Unit lost	never	No
0.2991.1.1	never	No

---

**RS 485 serial connection cable**

---

Shielded cable to be used: Belden 9841, RS-485, 1x2x24 AWG SFTP, 120 Ohm.



---

**PC Sabianet Software**

---

Installation example with a Carisma CFP-ECM network with MB board.

(\*) In the event of more than 60 units, add one or more Router-S (see next page).

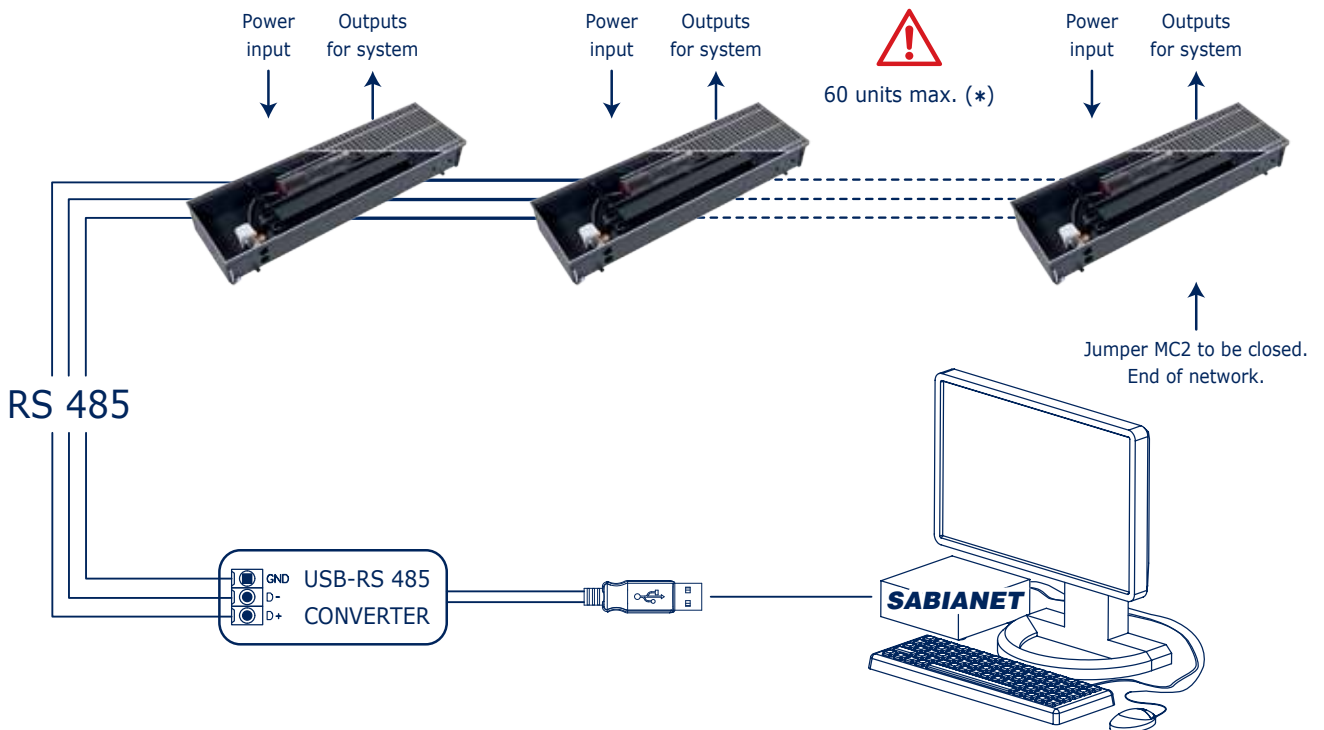

## SIOS Accessory

SIOS is a board equipped with 8 relays with potential free contact to control the activation or deactivation of remote electric utilities. Moreover, the board has 8 digital inlets to display the actuators or external consents, such as motor or other.

The SIOS boards can be connected:

- inside a network managed by Sabianet
- inside a network managed by T-DI
- inside a network managed by SabWeb
- to a PSM-DI panel (one SIOS for each PSM-DI panel)

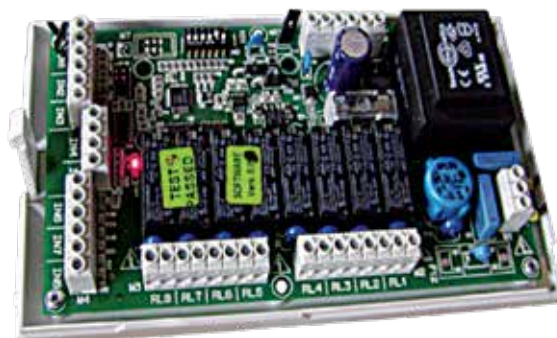

Identification	Code
SIOS	3021292

**For certified electronic KNX boards, contact the Sabiana technical department.**

### Router-S

The Router-S is an electronic board that allows to control several units inside a network managed by SABIANET (default) or within a sub-network managed by BMS systems, that are not provided by SABIANA (it is necessary to operate on a Dip Switch on the board).



#### Managed by SABIANET

The Router-S in the standard version is an electronic board that:

- allows creating networks with more than 60 units (minimum 2 Router-S are required) or to divide the network (per floor, building, etc.).
- allows creating a Master/Slave sub-network to be controlled as an independent group.

The number of Router-S to be used is:

- up to 60 units: no Router-S.
- from 61 to 120 units: 2 Router-S.
- every 60 subsequent units: 1 additional Router-S.

#### Managed by BMS Systems which are not provided by Sabiana

The Router-S becomes an electronic board to use with BMS systems not supplied by SABIANA, only after having set the Dip Switch on the board and so creating a Master/Slave sub-network to be controlled as an independent group.

The number of Router-S to use is:

- maximum 14 Router-S.
- maximum 15 Fan Coils per Router-S.

Identification	Code
Router-S	3021290

The KNX bus system is a building automation standard for controlling, managing and monitoring a wide range of products for:

- heating, cooling, ventilation
- lighting
- alarm systems
- audio and video systems
- electricity and gas

Since 2016, Sabiana is a certified member of the KNX association and the certified products can be added to this system in compliance with the tests carried out at KNX laboratories.



#### **KNX DEVICES**

The Sabiana **WM-KNX** room thermostat controls and adjusts the temperature of a room or area in a building. In combination with one or several **CFP-KNX** power unit kits, the thermostat is able to control the operation of terminal units such as fan coils. The appliance consists of an **LCD** display with adjustable backlight and a sensor for measuring the room temperature.

**WM-KNX** is to be used only with **CFP-KNX** and **PL** mounting plate. It is suitable for installation in a recessed wall box.



**WM-KNX**  
***Recessed thermostat***



**WM-KNX**  
***with rectangular plate***



**WM-KNX**  
***with square plate***



**CFP-KNX power unit kit**  
**CFP-KNX**

All the controls are described in detail in the "Fan Coil Control Range" literature.



**Perimeter listel with finish of cover grid**



**System for height regulation (pre-mounted with anti-vibrating system)**

## Angle models



- Available with all models and all casing sizes.
- The  $\alpha$  angle can vary from  $50^\circ$  to  $320^\circ$ .
- When placing the order, you must supply a detailed drawing or a shape.
- Feasibility only after technical inspection.
- The trench convector must be transportable.

### Drawing with dimensions

Cut

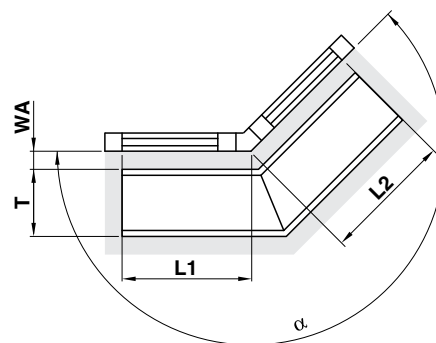
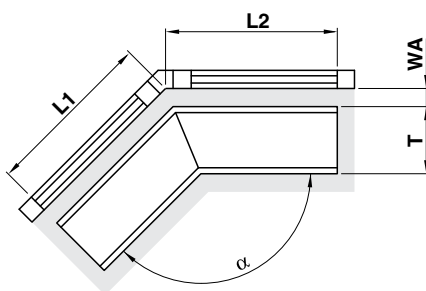
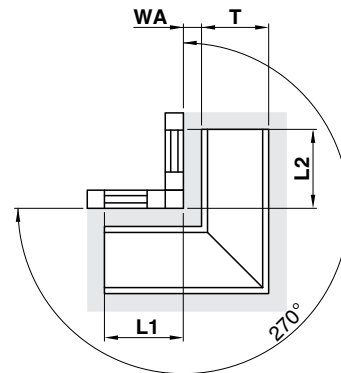
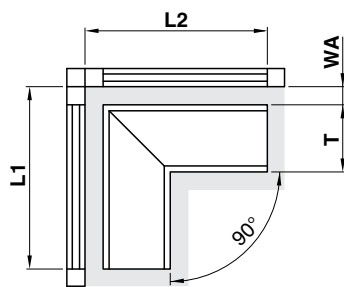

#### LEGEND:

**L1/L2** = Length of leg, measured on the wall

**$\alpha$**  = Angolo

**T** = Casing width

**WA** = Distance from wall



## Curved models



- Minimum curvature radius R: 1000 mm.
- When placing the order, you must supply a detailed drawing or a shape.
- Feasibility only after technical inspection.
- The trench convector must be transportable.

### Drawing with dimensions

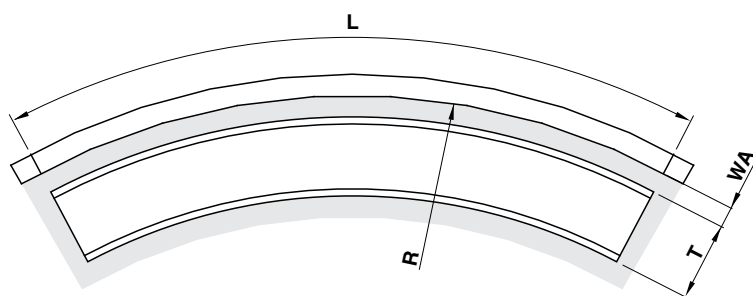

Inside radius

Outside radius

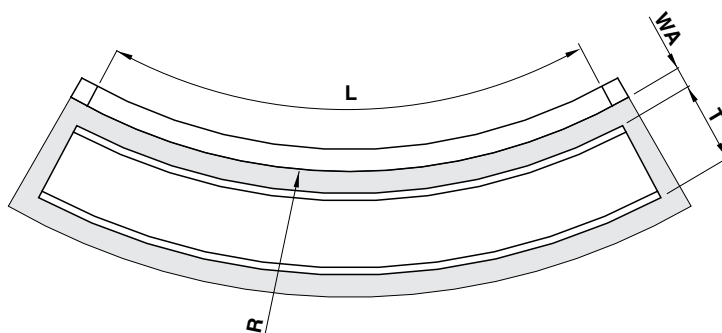

#### LEGENDA:

**L** = Extended length

**R** = Wall curvature radius

**T** = Casing width

**WA** = Distance from wall

## Models with column



- Available with all models and all casing sizes.
- When placing the order, you must supply a detailed drawing or a shape.
- Feasibility only after technical inspection.
- The trench convector must be transportable.

### Drawing with dimensions

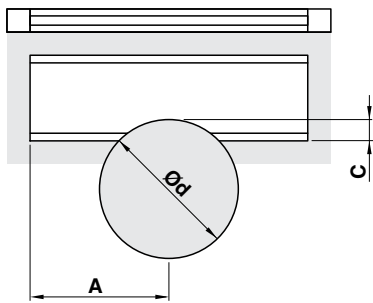

**Duct column cut**

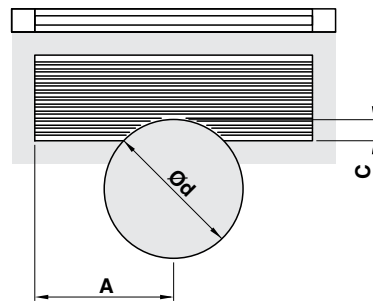

**Linear grid column cut**

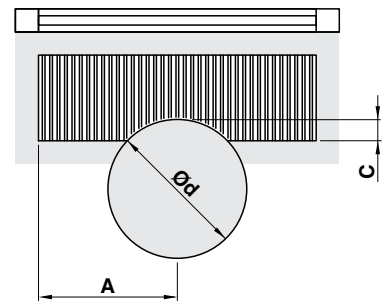

**Roll-up grid column cut**

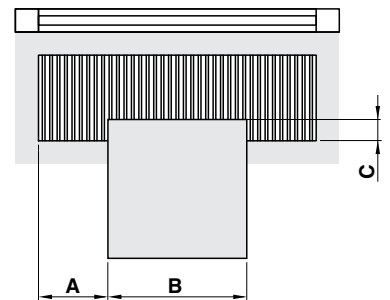
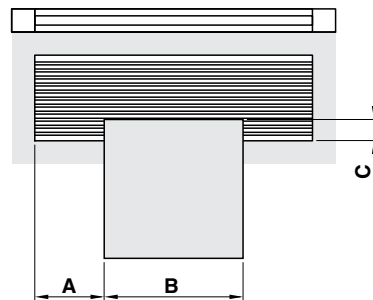
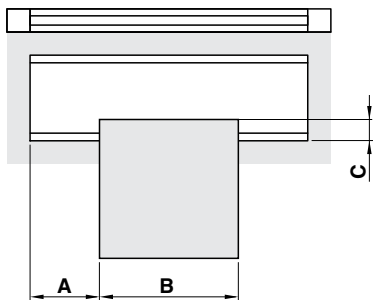

**LEGENDA:**

**d** = Diameter      **A** = Cut length  
**B** = Cut width      **C** = Cut depth

## Further special models

Type	Description	Identification	Code
Special pressure	High pressure 16 bar (1600 kPa)	DRU	16
Special versions	Special heating and cooling model lengths <sup>1)</sup> > 1250 mm possible	BES	SBL
	Lengths lower than minimum foreseen 850 mm - < 1250 mm possible (CFP-ECM 2T) 1050 mm - < 1250 mm possible (CFP-ECM 4T)	BES	SBL
	Special custom-designed lengths <sup>2)</sup>	BES	SBT
	Special custom-designed heights <sup>3)</sup>	BES	SBH
Fastening	Fastening with special brackets	-	-
Special painting	Painting in different RAL colours Linear grid / Roll-up aluminium grid Casing and thermal exchange coil	AUS FAR1	SF 99
	Painting in other RAL colours (RAL 7016 standard) Casing and thermal exchange coil	FAR1	SF

(1) = specify the exact length.

(2) = specify the exact width.

(3) = specify the exact height.

## Availability on demand

Type	Description	Identification	Code
Perimeter listel			
Natural anodised	Natural anodised	RDL	ELO
Colour anodised	Bronze anodised	RDL	BRO
	Brass anodised	RDL	MES
	Dark silver anodised	RDL	DKS
	Black anodised	RDL	SWZ
	Steel anodised	RDL	EDS
	Painting	Perimeter listel painted like floor duct/coil	RDL
Perimeter listel painted like cover grid		RDL	FAR2

Type	Description	Identification	Code
Air Filter			
Intake air filter	Intake air filter black PP130, 140 x 3 mm	FVL	FV

## Assembly and installation advice

### Preliminary warnings

#### Technical information

The technical information refers to the standard version of the products, with the reservation of usual variations and tolerances for the sector.

#### Operating conditions

- Suitable for use in heating systems with hot water according to standards DIN 18380 and water quality pursuant to directive VDI 2035.
- Sabiana recessed floor fan coil unit are not suitable to be used in steam heating systems.

CFP-ECM 2T / CFP-ECM 4T		
Operating features	Standard version	High pressure version
Operating pressure [bar (kPa)]	10,0 (1000)	16,0 (1600)
Test pressure [bar (kPa)]	13,0 (1300)	20,8 (2080)
Maximum temperature [ °C]	90	90

*If there is no indication regarding operating pressure, the standard version is supplied.*

#### Water quality

The operational requirements of the directive VDI 2035 regarding water quality and the assembly directives in use in the industry must be complied with. Warranty obligations, agreed based on our General Sales, Supply and Payment Terms and Conditions, become null and void in case of:

- emptying the plant periodically or for long periods;
- operating with steam;
- introducing additives to the water of the heating system (e.g. chemical substances, antifreeze) with aggressive action on copper and gaskets;
- excess sedimentation inside the fan coil unit;
- periodical or constant infiltration of oxygen into the system (e.g. through non-hermetic pipes);
- non-hermetic heating system.
- system not protected against freezing.

#### Special versions with drawing

If necessary, the customer is presented with a drawing with the dimensions of the special version, to be checked and approved. The order will be fulfilled when the approved drawings are returned. Should the order be cancelled, the customer must reimburse any expenses sustained and services provided up until that moment.

#### Painting

Powder painting (complete) in all RAL tones according to the customer's specifications, possibility making chromatic changes normally accepted in the industry.

Only use original RAL samples to make sure the colour is compatible.

For technical production purposes, slight chromatic variations between the coats can be detected, even based on different lighting conditions. Deformities can also be detected by comparing the painting of surfaces and ceramic products.

For technical printing purposes, the colours represented could be slightly different than the real colours.

Floor ducts and aluminium grids are painted in compliance with standard DIN 55900. Therefore they must be transported with the utmost caution and protected from any risk of damage in the worksite.

---

## Assembly and installation instructions

---

---

### Supply features

---

- Height adjustable, external and acoustically decoupled (pre-assembled) devices.
- For **CFP-ECM 2T** and **CFP-ECM 4T** aluminium roll-up grid (on demand, it also be supplied at the end of the installation phase).
- Rubber elements for acoustic decoupling.
- Assembly cover and perimeter listel protection (come such as protections during installation).

---

### Design indications

---

- To compensate the diffusion of cold air through windows with large surfaces, the fan coil unit must be installed in the floor along the entire length of the windows.
- Due to thermal conditions, the screed and floor could compress the casing of the recessed floor fan coil unit. Appropriate expansion joints must be provided to avoid this problem.
- A duct must be installed when using electric lines or thermostatic head with a remote sensor.
- The assembly cover supplied is to protect the fan coil unit while being installed and must be replaced with the linear or roll-up grid when assembly has finished. The assembly cover can bear limited loads and must not be used to support scaffolding, cables, etc.
- The trench convector must always be easily accessible to be able to perform maintenance.

---

### Assembly indications

---

#### Positioning and alignment

- Before starting assembly, remove the film and packaging of the trench convector.  
If a cover grid has also been supplied, keep it in a safe place until the assembly operations are over.
- Bring the trench convector in place and align it using external adjustment devices.  
They can be positioned correctly using a screwdriver.
- Fasten the casing to the floor with the assembly wedges.
- If needed, apply insulating material underneath and to the sides of the duct.

#### Connecting the trench convector to the floor

- The water connection must normally be made on the front or ambient side, through the specific openings for passage of the pipes (on demand, possibility of different connection solutions).
- Fasten with screws and connect the pipes.
- To keep floor material from invading the casing, seal the openings with suitable material (e.g. membrane from Accessories catalogue).
- Bleed air from the coil through the specific vents.
- Perform a pressurised test.
- Cover the trench convector with the supplied assembly cover.
- If using components of other manufacturers (e.g. connection kit, actuators etc.) not included in the Sabiana accessories catalogue, pay attention to the overall dimensions.

#### Intended use

**CFP-ECM 2T** and **CFP-ECM 4T** fan coil units are only intended for indoor use (e.g. verandas, residential rooms, exhibition halls, etc.). The fan coil unit cannot be used in swimming pools, moist rooms or outdoors. If in doubt, consult the manufacturer. Any other use is considered nonconforming to the intended use.

#### Safety warnings

- Electrical interventions can only be carried out by an authorised electrician. The electrical connections must be made respecting VDE requirements and EVU directives in force.
- To install the CFP-ECM 2T and CFP-ECM 4T fan coil unit, an appropriate residual current device (RCD) / circuit breaker switch FI (less than 30 mA) must be used.
- It is recommended to implement an electric line exclusively for the fan coil unit.
- Failure to comply with the requirements and directives can lead to functional failures with relative harmful consequences and place personal safety in danger. RISK OF DEATH in case of accidental exchange of cables or incorrect electrical connection!
- Carefully read the safety warnings in the installation manual as well.



*IQNet, the association of the world's first class certification bodies, is the largest provider of management System Certification in the world. IQNet is composed of more than 30 bodies and counts over 150 subsidiaries all over the globe.*

CERTIFICATO n. 0545/7  
CERTIFICATE No. \_\_\_\_\_

SI CERTIFICA CHE IL SISTEMA DI GESTIONE PER LA QUALITÀ DI  
WE HEREBY CERTIFY THAT THE QUALITY MANAGEMENT SYSTEM OPERATED BY

**SABIANA S.p.A.**

Sede e Unità Operativa: Via Piave, 53 - 20011 Corbetta (MI)  
Direzione e uffici amministrativi, progettazione, produzione di apparecchiature per il riscaldamento e il condizionamento dell'aria (aerotermi, termostrisce radianti, unità trattamento aria) e canne fumarie.

Unità Operativa: Via Virgilio, 2 - 20013 Magenta (MI)  
Produzione di ventilconvettori, magazzino e logistica

Italia

È CONFORME ALLA NORMA / IS IN COMPLIANCE WITH THE STANDARD

**UNI EN ISO 9001:2015**

Sistema di Gestione per la Qualità / Quality Management System

PER LE SEGUENTI ATTIVITÀ / FOR THE FOLLOWING ACTIVITIES

**EA: 18**

Progettazione, produzione e assistenza di apparecchiature per il riscaldamento e il condizionamento dell'aria (aerotermi, termostrisce radianti, ventilconvettori e unità trattamento aria) e canne fumarie.

*Design, production and service of heating and air conditioning equipment (unit heaters, radiant panels, fan coil units and air handling units) and chimneys.*

Ritornarsi alla documentazione del Sistema di Gestione per la Qualità aziendale per l'applicabilità dei requisiti della norma di riferimento.  
Refer to the documentation of the Quality Management System for details of application to reference standard requirements.

Il presente certificato è soggetto al rispetto del documento ICIM "Regolamento per la certificazione dei sistemi di gestione" e al relativo Schema specifico.  
The use and the validity of this certificate shall satisfy the requirements of the ICIM document "Rules for the certification of company management systems" and specific Scheme.

Per informazioni puntuali e aggiornate circa eventuali variazioni intervenute nello stato della certificazione di cui al presente certificato, si prega di contattare il n° telefonico +39 02 725341 o indirizzo e-mail info@icim.it.  
For timely and updated information about any changes in the certification status referred to in this certificate, please contact the number +39 02 725341 or email address info@icim.it.

Data emissione  
First issue  
10/06/1996

Emissione corrente  
Current issue  
10/04/2018

Data di scadenza  
Expiring date  
09/04/2021

  
ICIM S.p.A.  
Piazza Don Enrico Mapelli, 75 - 20099 Sesto San Giovanni (MI)  
www.icim.it



SGQ N° 004 A PRD N° 004 B  
SGA N° 005 D PRS N° 082 C  
SGE N° 005 M ISP N° 046 E  
SCR N° 006 F ETS N° 003 D  
SSI N° 008 G EMAS N° 001 P

Membro degli Accordi di Mutuo Riconoscimento EA, IAF e ILAC  
Signatory of EA, IAF and ILAC Mutual Recognition Agreements



www.cisq.com

CISQ è la Federazione Italiana di Organismi di Certificazione dei sistemi di gestione aziendale.  
CISQ is the Italian Federation of management system Certification Bodies.





THE INTERNATIONAL CERTIFICATION NETWORK

# CERTIFICATE

CISQ/ICIM SPA has issued an IQNet recognized certificate that the organization:

## SABIANA S.p.A.

Head Office and Operative Unit  
Via Piave, 53 - I-20011 Corbetta (MI)  
Operative Unit

Via Virgilio, 2 - I-20013 Magenta (MI)

has implemented and maintains a

## Quality Management System

for the following scope:

**Design, production and service of heating and air conditioning equipment  
(unit heaters, radiant panels, fan coil units and air handling units) and chimneys.**

which fulfils the requirements of the following standard:

## ISO 9001:2015

Issued on: **2018-04-10**  
First issued on: **1996-06-10**  
Expires on: **2021-04-09**

*This attestation is directly linked to the IQNet Partner's original certificate and shall not be used as a stand-alone document.*

Registration Number: **IT-4000**



Alex Stoichitoiu  
President of IQNET



Ing. Claudio Provetti  
President of CISQ

### IQNet Partners\*:

AENOR Spain AFNOR Certification France APCER Portugal CCC Cyprus CISQ Italy  
CQC China CQM China CQS Czech Republic Cro Cert Croatia DQS Holding GmbH Germany FCAV Brazil  
FONDONORMA Venezuela ICONTEC Colombia Inspecta Sertifiointi Oy Finland INTECO Costa Rica  
IRAM Argentina JQA Japan KFQ Korea MIRTEC Greece MSZT Hungary Nemko AS Norway NSAI Ireland  
NYCE-SIGE México PCBC Poland Quality Austria Austria RR Russia SII Israel SIQ Slovenia  
SIRIM QAS International Malaysia SQS Switzerland SRAC Romania TEST St Petersburg Russia TSE Turkey YUQS Serbia  
IQNet is represented in the USA by: AFNOR Certification, CISQ, DQS Holding GmbH and NSAI Inc.

\* The list of IQNet partners is valid at the time of issue of this certificate. Updated information is available under [www.iqnet-certification.com](http://www.iqnet-certification.com)





The descriptions and illustrations provided in this publication are not binding: Sabiana reserves the right, whilst maintaining the essential characteristics of the types described and illustrated, to make, at any time, without the requirement to promptly update this piece of literature, any changes that it considers useful for the purpose of improvement or for any other manufacturing or commercial requirements.



A company of Arbonia Group  
**ARBONIA** 

Follow us on



Sabiana app



---

**SABIANA SpA**

Società a socio unico

Via Piave 53 - 20011 Corbetta (MI) Italy

T. +39 02 97203 1 r.a. • F. +39 02 9777282

info@sabiana.it

**www.sabiana.it**