



Product is subject to and complies
with Regulation EU 1253/14 - ERP2018

Energy Smart Recovery Units

controlled mechanical
ventilation system

TECHNICAL MANUAL

Energy Smart



Contents

	General features	3
	The range	10
	Fast unit selection	12
VERTICAL VERSION	Dimensions and weight	16
	Wall installation	18
	Floor installation	19
	Pro ENY-SP version with advanced air flow control	20
	Standard ENY-S version with programmed timing profile control	21
	ENY-SP and ENY-S - Construction features of the main components	22
	Modes	24
	Thermal performance	25
	Efficiency curves	26
	HORIZONTAL VERSION	Dimensions and weight
Pro ENY-SHP Version with advanced air flow control		39
Construction features of the main components		42
Modes		48
Efficiency curves		56
Selection procedure		60
Free-cooling and Free-heating management		63
Control panel		64
Centralised control		66
Versions with fitted electric heaters		67
Accessories		68
Air distribution system		71
Circular ducts		75
Semicircular ducts		91
Circular ducts for EPE		108
Accessories for ducts		123
Diffusers		131
Sizing		140
Table of compliance with Regulations EU 1253/14 and EU 1254/14		142
CE Declaration		146
Passivhaus Certificate	150	



Energy Smart ENY-SP Vertical Units

The Sabiana Energy Smart units are high efficiency ventilation units with heat recovery, designed for residential applications.

The units replace the exhaust air of indoor environments with outdoor filtered air by means of a high efficiency ePM₁ 55% - F7¹.

The hexagonal counterflow heat recovery unit prevents any winter heat drops due to the introduction of fresh air, thereby recovering up to 92.5%² of the extracted heat and conveying it to the clean air introduced in the occupied environment. Each unit is also equipped with an average (ePM₁₀ 50% - M5) efficiency filter³ installed on the inlet of the extraction section to prevent any dust from getting into the equipment.

All Energy Smart units comply with the 2018 efficiency limits imposed by Regulation 1253/14⁴.

The Pro versions are equipped with an automatic centralized air flow control system operated by an integrated humidity sensor located in the extraction air duct. If the humidity of the indoor environment exceeds the reference parameters, to prevent the proliferation of mould and pathogenic bacteria, the fresh air flow is increased with the aim of restoring a healthy humidity level. The control also prevents from dropping below excessively low humidity levels, thus preventing excessively dry conditions inside the environments and, as a result, any health hazards. The units are NOT able, by themselves, to lower the level of internal humidity to a value below that of the outdoor humidity. All the units can be controlled by means of a **supervisory system** in accordance with the following protocols:

- **Modbus**, with direct access to the dedicated RS 485 web gateway
- **Konnex**, with KNX interface board (optional)

1 ePM₁ 55% - F7 filtering efficiency compliant with Standard ISO 16890

2 Thermal efficiency compliant with Regulation EU 1253/2014

3 ePM₁₀ 50% - M5 filtering efficiency compliant with Standard ISO 16890

4 Regulation EU 1253/14 does not apply to the ENY-SHP-150 unit as the nominal power input of each fan is less than 30W

ENERGY SMART CONSTRUCTION

The range can be classified according to the installation and control types:

- **Pro unit** with automatic centralized control via humidity probe:
 - ENY-SP (vertical)
 - ENY-SHP (horizontal-vertical)
- **Standard unit** with time programming control:
 - ENY-S (vertical)

ENY-SP and ENY-S units are designed for vertical wall installation or, with the addition of feet, floor installation.

Instead, ENY-SHP units are ideal for both horizontal ceiling installation and vertical wall installation.

The width of the ENY-SHP and ENY-S units is such as to ensure easy insertion into modular kitchen components, since the width is less than 600 mm.



Energy Smart SHP 150 Unit

Energy Smart Vertical Units: ENY-SP and ENY-S

The Pro Versions are available in class A + while the Standard versions are in Class A. Both are equipped with high efficiency backward-curved blades and EC motors, driven by the integrated inverter control board for variable speed control.

All units have a remote control user interface (T-EP control), fitted in the frontal panel of ENY-SP and ENY-S units; it is also possible to disconnect the interface from the frontal panel and place it on the wall using a special cable.

The Pro versions are Passivhaus certified and are equipped with a centralized automatic flow rate control system, that works not only in accordance with a built-in humidity sensor, but also in response to CO₂ measurements. In this case, it is recommended to connect a 0-10V CO₂ sensor to the main control board, available on the market.



T-EP control

For more details about centralized control see chapter at page 64.



The units with automatic control via humidity or CO₂ sensor can enable the “AUTO” mode. In this mode, the fan speed is controlled by an automatic control cycle relating to internal instantaneous humidity and CO₂ variations. In variable-flow automatic control mode, the user can still intervene at any time by changing the fan speed manually as required.

The automatic mode will be restored at the next significant variation of ambient humidity or concentration of CO₂.

In the event that the user does not require automatic control but just simply time programming or even manual control, standard units are ideal.

There is a choice of 8 weekly programs for these units: 4 preset programs and 4 free programs that can be modified as required. The operation can be selected in various intervals of the day, **at one of the four standard speeds**, or at the hyperventilation speed “Party”. At any time, the user may force the programming manually, which will resume at the beginning of the next time interval.

In manual mode, in addition to the nominal speed, **there are 3 default speeds equal to 70%, 45%, and 25% of the project flow rate**. The timed intensive ventilation modes can be activated via the user interface (“Party” mode) or via a remote switch located in a particular room (“Booster” mode).

All the units are equipped with an automatic bypass system that totally disables use of the heat recovery unit to permit 100% **free-cooling** (or **free-heating**). The system is controlled by logic subject to the feedback of the integrated temperature sensors.

Also, the units have the following integrated control logic:

- The mass supply flow defined by the user is kept constant in all outdoor climatic conditions.
- The extraction flow is kept at a constant balancing percentage compared to the air supply flow, in order to preserve the desired overpressure or negative pressure for all operating conditions.

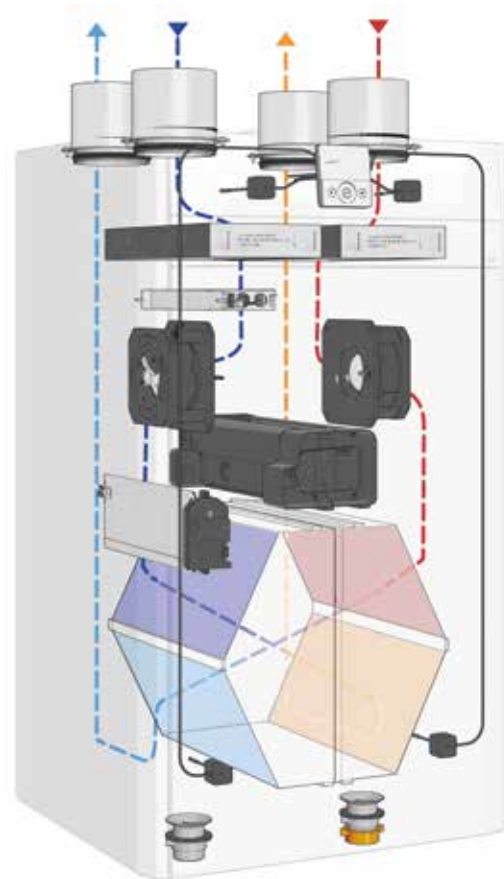

When installing the units in homes located in regions with particularly harsh climatic conditions¹, we recommend installing the units with integrated filament electric heaters (E versions), where the thermal power is continuously modulated to maintain exhaust air at the desired temperature, preventing freezing². For all models, it is possible to use an external antifreeze coil, with continuous modulation.

To prevent excessive efficiency drops due to filter clogging, it is recommended to replace the filters at the end of the recommended period (usually every 6 months). The increase in filter dirt in fact leads to increased fan rotation resistance, causing a significant drop in flow rates. With regard to ENY-S units, the automatic constant flow control system (standard for the ENY-SP units), which prevents any drops in flow rates due to filter clogging, is available as an accessory. In this case, filter clogging may result in a significant increase in power consumption of the fans.

If the flows need to be inverted, all vertical units are reversible during installation (except for versions with electric heater).

For each model, a complete set of Accessories is also available to meet any installation need.

¹ Minimum outdoor temperature below -10 °C

² The ENY-SP units with antifreeze protection systems are Passivhaus certified

Energy Smart Horizontal and Vertical Units: ENY-SHP



The Energy Smart horizontal units are available in three sizes ENY-SHP-150, ENY-SHP-170 and ENY-SHP-270, in the Pro version only, that means they are equipped with an automatic centralized air flow control system operated by an integrated humidity sensor located in the extract air duct; the 150 and 170 sizes are Passivhaus certified. The units are ideal for both horizontal ceiling installation and vertical wall installation.

The **SHP - 150** is distinguished by its extremely compact dimensions that make it easy to install in a false ceiling. The unit is equipped with a fitted control panel, that lets the calibration and activation of the unit. The Energy Smart SHP-150 unit can be connected to the T-EP remote control panel accessory to activate the following additional functions:

- Party Mode.
- Holiday Mode.
- Free-Cooling Mode: a single supply air flow to activate manually.
- There is a choice of 8 weekly programs for these units: 4 preset programs and 4 free programs that can be modified as required.
- Fan speed regulation by means of the T-EP touch pad by selecting one of the 3 default speeds equal to 70%, 45%, and 25% of the project flow rate.

The **SHP - 170** size, like the Energy Smart Pro vertical units, is equipped as standard with a T-EP control panel. The ENY-SHP 170 is equipped with a motorized bypass system with a double damper, that totally disables use of the heat recovery unit to permit 100% free-cooling (or free-heating) automatically. The ENY SHP-170 is also available with integrated filament electric heaters (E version), in which the thermal power is continuously modulated to keep the exhaust air at the desired temperature, thereby preventing any freezing.

The **SHP - 270** is distinguished by the perfect blend between compact dimensions and high air flows. The unit is equipped as standard with a T-EP control panel.

The ENY-SHP-270 is equipped with a motorized bypass system with a double damper, that totally disables the heat exchange between the air flows to permit 100% free-cooling (or free-heating) automatically.

The ENY-SHP-270 is also available with integrated filament electric heaters (E version), in which the thermal power is continuously modulated to keep the exhaust air temperature always within the safety limits, thereby preventing any freezing.

The ENY-SHP-270 is also equipped as standard with two humidity sensors and an advanced flow control system which allows an optimal control of the environment hygrometric conditions.

Vertical version with T-EP built-in/wall control

Pro Version

Version	Model	Max flow at 100 Pa (m ³ /h)	Energy class	Width (mm)	Humidity Sensor	Automatic air flow control	Code
Pro	ENY-SP-180	180	A+	600	✓	✓	021B001
	ENY-SP-280	280	A+	600	✓	✓	021B002
	ENY-SP-370	370	A+	660	✓	✓	021B003
	ENY-SP-460	460	A	660	✓	✓	021B004
	ENY-SP-600	600	A	660	✓	✓	021B005
Pro with LH electric heater	ENY-SPEL-180	180	A+	600	✓	✓	021B011
	ENY-SPEL-280	280	A+	600	✓	✓	021B012
	ENY-SPEL-370	370	A+	660	✓	✓	021B013
	ENY-SPEL-460	460	A	660	✓	✓	021B014
	ENY-SPEL-600	600	A	660	✓	✓	021B015
Pro with RH electric heater	ENY-SPER-180	180	A+	600	✓	✓	021B021
	ENY-SPER-280	280	A+	600	✓	✓	021B022
	ENY-SPER-370	370	A+	660	✓	✓	021B023
	ENY-SPER-460	460	A	660	✓	✓	021B024
	ENY-SPER-600	600	A	660	✓	✓	021B025

Standard version

Version	Model	Max flow at 100 Pa (m ³ /h)	Energy class	Width (mm)	Humidity Sensor	Automatic air flow control	Code
Standard	ENY-S-170	170	A	550	(*)	(**)	021A001
	ENY-S-270	270	A	550	(*)	(**)	021A002
	ENY-S-360	360	A	550	(*)	(**)	021A003
	ENY-S-460	460	A	660	(*)	(**)	021A004
	ENY-S-600	600	A	660	(*)	(**)	021A005
Standard with LH electric heater	ENY-SEL-170	170	A	550	(*)	(**)	021A011
	ENY-SEL-270	270	A	550	(*)	(**)	021A012
	ENY-SEL-360	360	A	550	(*)	(**)	021A013
	ENY-SEL-460	460	A	660	(*)	(**)	021A014
	ENY-SEL-600	600	A	660	(*)	(**)	021A015
Standard with RH electric heater	ENY-SER-170	170	A	550	(*)	(**)	021A021
	ENY-SER-270	270	A	550	(*)	(**)	021A022
	ENY-SER-360	360	A	550	(*)	(**)	021A023
	ENY-SER-460	460	A	660	(*)	(**)	021A024
	ENY-SER-600	600	A	660	(*)	(**)	021A025

Horizontal and vertical version

Version	Model	Max flow at 100 Pa (m ³ /h)	Energy class	Height (mm)	Humidity Sensor	Automatic air flow control	T-EP	Code
Pro	ENY-SHP-150	150	A	191	✓	✓	(***)	021C002
	ENY-SHP-170	170	A+	330	✓	ND	✓	021C001
	ENY-SHPL-270 ⁽¹⁾	270	A	278	✓ ⁽³⁾	✓	✓	021C003
	ENY-SHPR-270 ⁽²⁾	270	A	278	✓ ⁽³⁾	✓	✓	021C003D
Pro left range with electric heater	ENY-SHPEL-170	170	A+	330	✓	ND	✓	021C011
	ENY-SHPEL-270	270	A	278	✓ ⁽³⁾	✓	✓	021C013
Pro right range with electric heater	ENY-SHPER-170	170	A+	330	✓	ND	✓	021C021
	ENY-SHPER-270	270	A	278	✓ ⁽³⁾	✓	✓	021C023

-
- (1) left configuration
 - (2) right configuration
 - (3) double sensor

(*) Humidity Sensor available as Accessory

(**) Pressure transducer for the automatic control of air flow rates, available as accessory

(***) T-EP wall control available as accessory

Energy Smart units are suitable for operation in balanced or slightly unbalanced flow and return conditions. They ensure residential air exchange, recovering the heat from the extracted air and conveying it to the clean air. The chart below shows the recommended operating ranges in terms of volumetric supply air flow rate at standard conditions and available external static pressure.

Pro ENY-SP Vertical Version

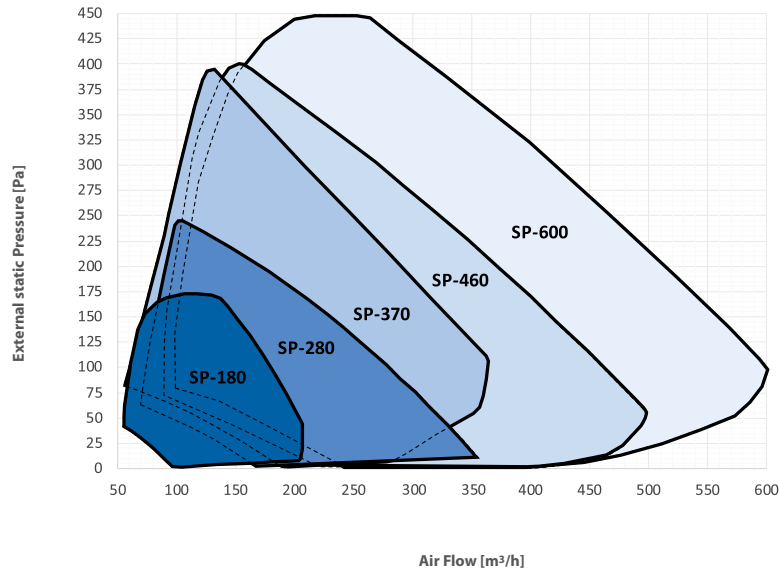

	ENY-SP-180	ENY-SP-280	ENY-SP-370	ENY-SP-460	ENY-SP-600*
Q_{max} [m³/h]	180	280	370	460	600
Q_{rif} [m³/h]	130	200	260	320	420
P_{el} [W]	23	35	47	76	105
η_{t_rvu} [%]	91,5%	91,4%	92,5%	88,6%	88,00%
SPI [W/m³/h]	0,174	0,174	0,179	0,237	0,247
CTRL	0,85	0,85	0,85	0,85	0,85
SEC [kWh/m²a]	-42,32	-42,29	-42,47	-40,10	-39,71
Energy class	A+	A+	A+	A	A
Filter efficiency	ePM ₁ 55% - F7 ePM ₁₀ 50% - M5	ePM ₁ 55% - F7 ePM ₁₀ 50% - M5	ePM ₁ 55% - F7 ePM ₁₀ 50% - M5	ePM ₁ 55% - F7 ePM ₁₀ 50% - M5	ePM ₁ 55% - F7 ePM ₁₀ 50% - M5
L_{WA} [dBa]	38,9	43,1	46,3	47,9	52,4
LK_I [%]	1,2%	0,7%	0,5%	0,3%	0,60%
LK_E [%]	1,7%	1,0%	0,8%	0,7%	1,84%
HEP [W]	500	900	1250	1600	2000

* = not Passivhaus certified unit

LEGEND | all terms must be considered in compliance with Standard EU 1253/2014

Q_{max}	Maximum flow rate, at max. motor speed and external static pressure of 100 Pa	SEC	Specific energy consumption
Q_{ref}	Reference flow rate - 70% of Q_{max}	L_{WA}	Sound power level emitted by structure
P_{el}	Power supply at Q_{ref} and external static pressure of 50Pa	LK_I	Internal leakage at 100 Pa compared to Q_{ref}
η_{t_rvu}	Thermal efficiency at Q_{ref}	LK_E	External leakage at 250 Pa compared to Q_{ref}
SPI	Specific power input	HEP	Pre-heater power (only mod. SPEL, SPER)
CTRL	Control factor - Centralised automatic control		

Standard ENY-S Vertical Version

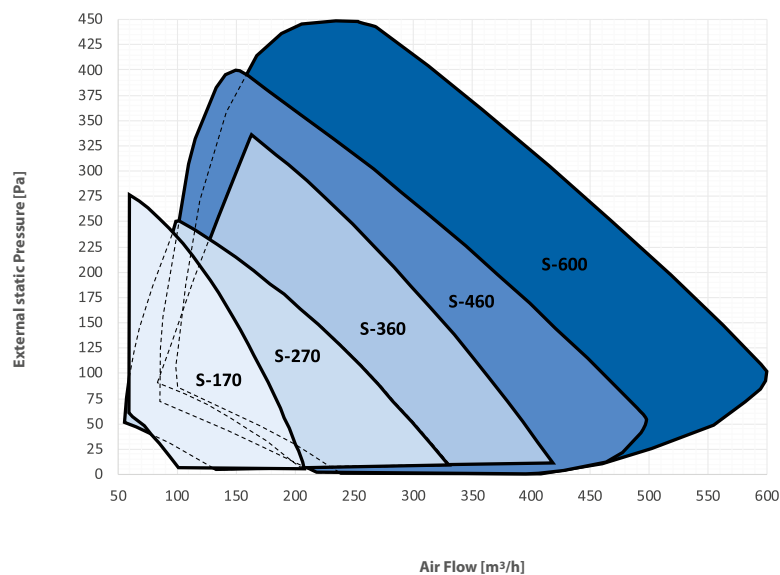

	ENY-S-170	ENY-S-270	ENY-S-360	ENY-S-460	ENY-S-600
Q_{max} [m ³ /h]	170	270	360	460	600
Q_{rif} [m ³ /h]	120	190	250	320	420
P_{el} [W]	22	35	53	76	104
η_{t_rvu} [%]	87,0%	86,5%	90,1%	88,6%	88,00%
SPI [W/m ³ /h]	0,183	0,184	0,209	0,237	0,247
CTRL -	0,95	0,95	0,95	0,95	0,95
SEC [kWh/m ² a]	-39,4	-39,3	-39,6	-38,4	-37,9
Energy class	A	A	A	A	A
Filter efficiency	ePM ₁ 55% - F7 ePM ₁₀ 50% - M5	ePM ₁ 55% - F7 ePM ₁₀ 50% - M5	ePM ₁ 55% - F7 ePM ₁₀ 50% - M5	ePM ₁ 55% - F7 ePM ₁₀ 50% - M5	ePM ₁ 55% - F7 ePM ₁₀ 50% - M5
L_{WA} [dBa]	40,6	46,6	49,0	47,9	52,4
LK_i [%]	0,4%	0,4%	0,7%	0,3%	0,60%
LK_E [%]	1,8%	1,4%	2,7%	0,7%	1,84%
HEP [W]	500	900	1250	1600	2000

LEGEND | all terms must be considered in compliance with Standard EU 1253/2014

Q_{max}	Maximum flow rate, at max. motor speed and external static pressure of 100 Pa	SEC	Specific energy consumption
Q_{ref}	Reference flow rate - 70% of Q_{max}	L_{WA}	Sound power level emitted by structure
P_{el}	Power supply at Q_{ref} and external static pressure of 50Pa	LK_i	Internal leakage at 100 Pa compared to Q_{ref}
η_{t_rvu}	Thermal efficiency at Q_{ref}	LK_E	External leakage at 250 Pa compared to Q_{ref}
SPI	Specific power input	HEP	Pre-heater power (only mod. SEL and SER)
CTRL	Control factor - Centralised automatic control		

ENY-SHP Pro Version

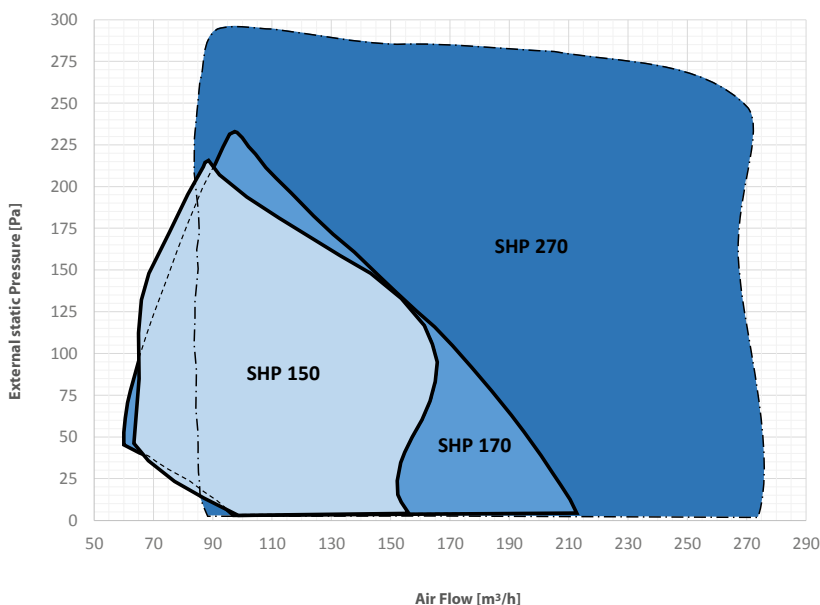

		ENY-SHP-150	ENY-SHP-170	ENY-SHP-270
Q_{max}	[m³/h]	150	170	270
Q_{rif}	[m³/h]	105	120	190
P_{el}	[W]	56	23	47,8
η_{t_rvu}	[%]	87%	92,1%	84,4%
SPI	[W/m³/h]	0,227	0,193	0,24
CTRL	-	0,85	0,85	0,85
SEC	[kWh/m²a]	-39,90	-42,05	-38,9
Energy class		A	A+	A
Filter efficiency		ePM ₁ 55% - F7 ePM ₁₀ 50% - M5	ePM ₁ 55% - F7 ePM ₁₀ 50% - M5	ePM ₁ 55% - F7 ePM ₁₀ 50% - M5
L_{WA}	[dBa]	38,0	44,9	41,3
LK_I	[%]	1,8%	0,5%	0,4%
LK_E	[%]	0,8%	2,3%	1,1%
HEP	[W]	-	600	900

LEGEND | all terms must be considered in compliance with Standard EU 1253/2014

Q_{max}	Maximum flow rate, at max. motor speed and external static pressure of 100 Pa	SEC	Specific energy consumption
Q_{ref}	Reference flow rate - 70% of Q_{max}	L_{WA}	Sound power level emitted by structure
P_{el}	Power supply at Q_{ref} and external static pressure of 50Pa	LK_I	Internal leakage at 100 Pa compared to Q_{ref}
η_{t_rvu}	Thermal efficiency at Q_{ref}	LK_E	External leakage at 250 Pa compared to Q_{ref}
SPI	Specific power input	HEP	Pre-heater power (only mod. SHPEL and SHPER)
CTRL	Control factor - Centralised automatic control		



Pro ENY-SP version

All Pro Versions are equipped with a humidity sensor and automatic flow rate calibration system; the units are also equipped with panels with insulating features that ensure a reduction in sound emissions in the environment.

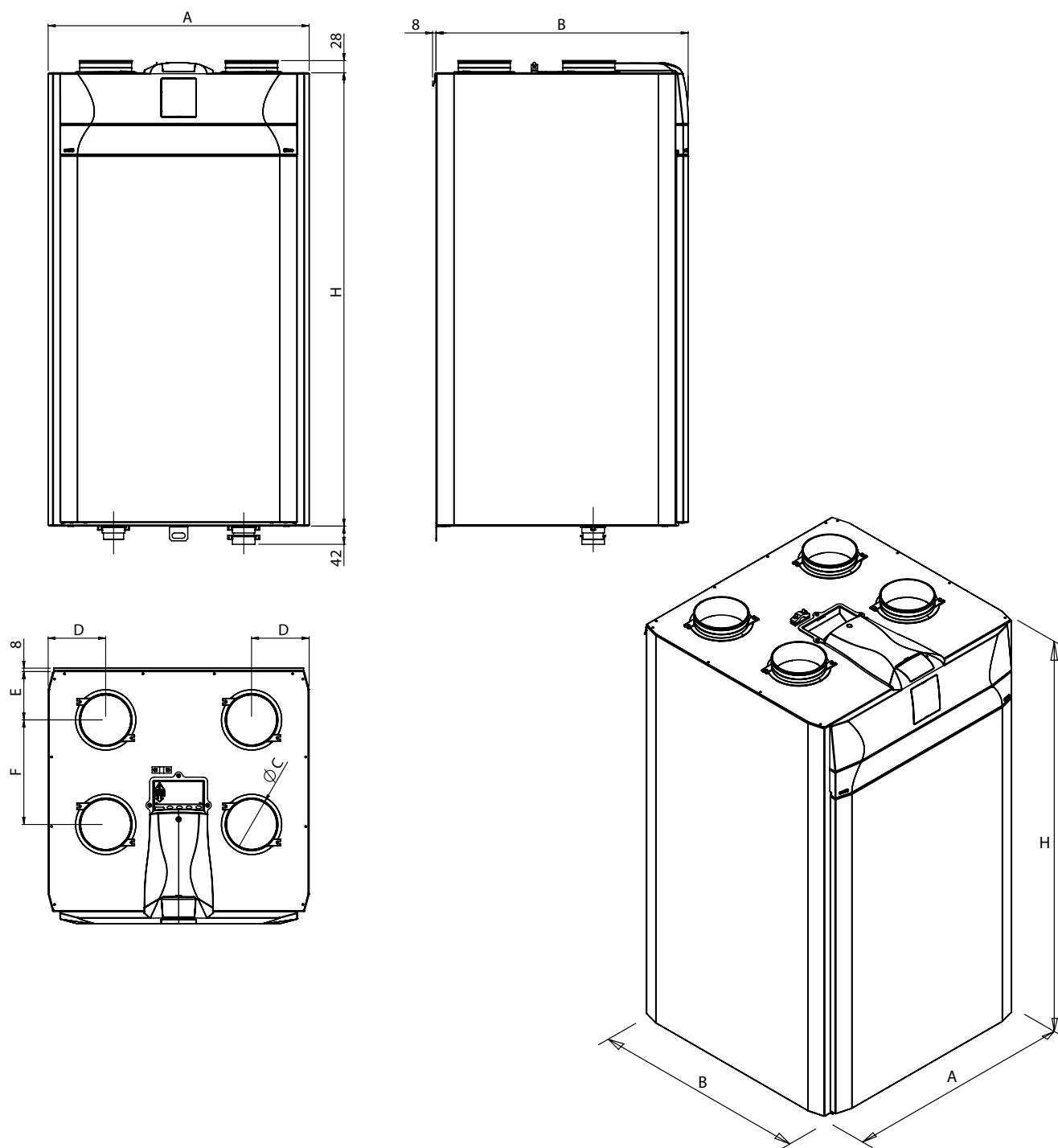

Model	A	B	Ø C	H	D	E	F	Weight with packaging	Weight without packaging
ENY-SP-180	600	580	125	1041	132	111	240	63 kg	47 kg
ENY-SP-280	600	630	160	1041	132	111	290	67 kg	51 kg
ENY-SP-370	660	680	160	980	147	126	305	75 kg	56 kg
ENY-SP-460	660	680	180	980	147	126	305	75 kg	59 kg
ENY-SP-600	660	680	180	980	147	126	305	75 kg	60 kg

Standard ENY-S version

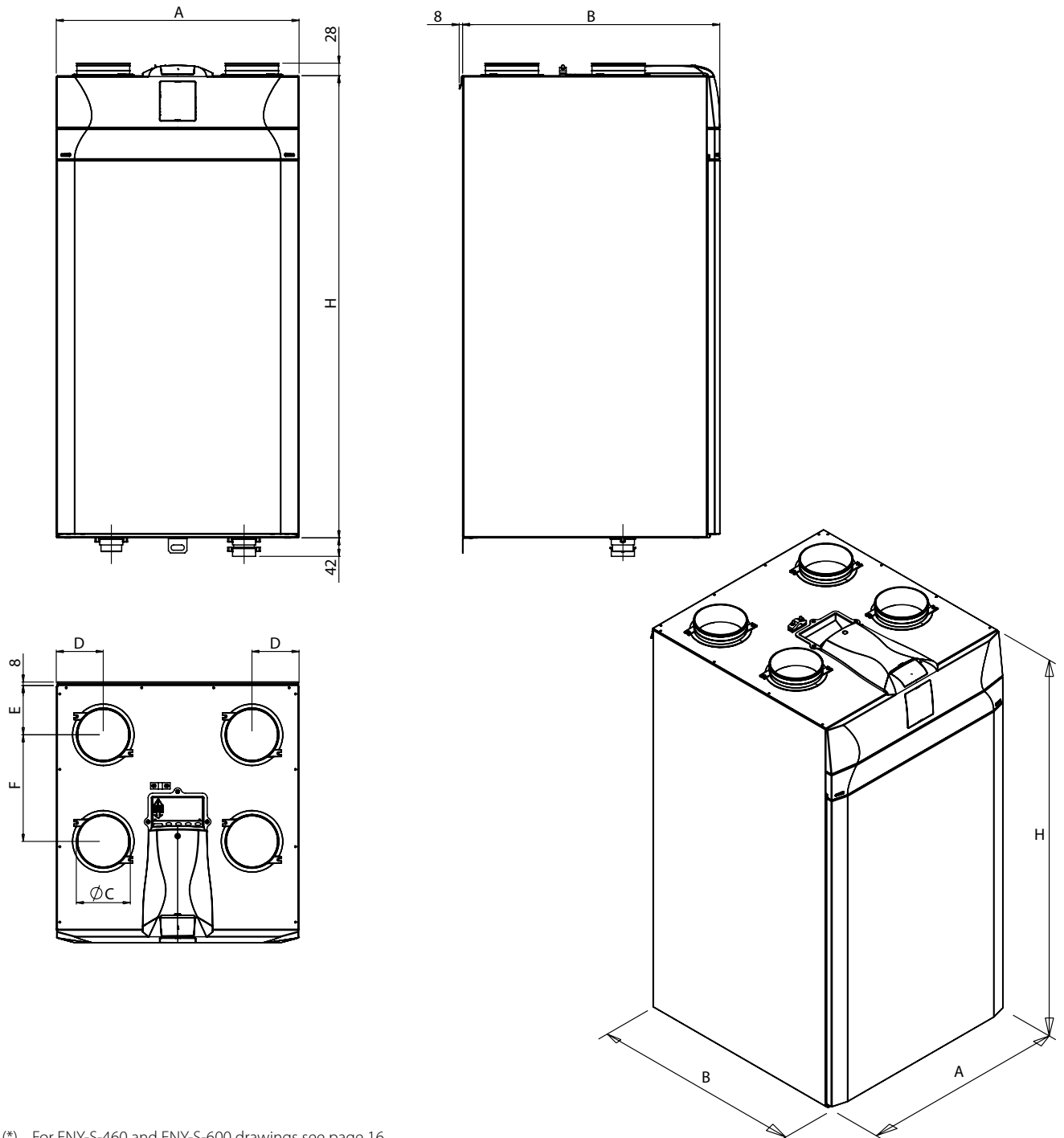

(*) For ENY-S-460 and ENY-S-600 drawings see page 16.

Model	A	B	Ø C	H	D	E	F	Weight with packaging	Weight without packaging
ENY-S-170	547	505	125	1041	106	93.5	212.5	56 kg	40 kg
ENY-S-270	547	580	160	1041	106	111	240	64 kg	48 kg
ENY-S-360	547	630	160	1041	106	111	290	66 kg	50 kg
ENY-S-460*	660	680	180	980	147	126	305	75 kg	59 kg
ENY-S-600*	660	680	180	980	147	126	305	75 kg	60 kg

Energy Smart | Vertical Version | WALL INSTALLATION

ENY-S and ENY-SP units can be easily installed on walls with the suspension brackets included in the unit. Along with the suspension brackets, an additional bracket is provided, to be placed at the bottom to further secure the unit. The back of the unit is provided with a rubber shim to prevent impacts that could damage the system.

General wall installation



Suspension brackets details

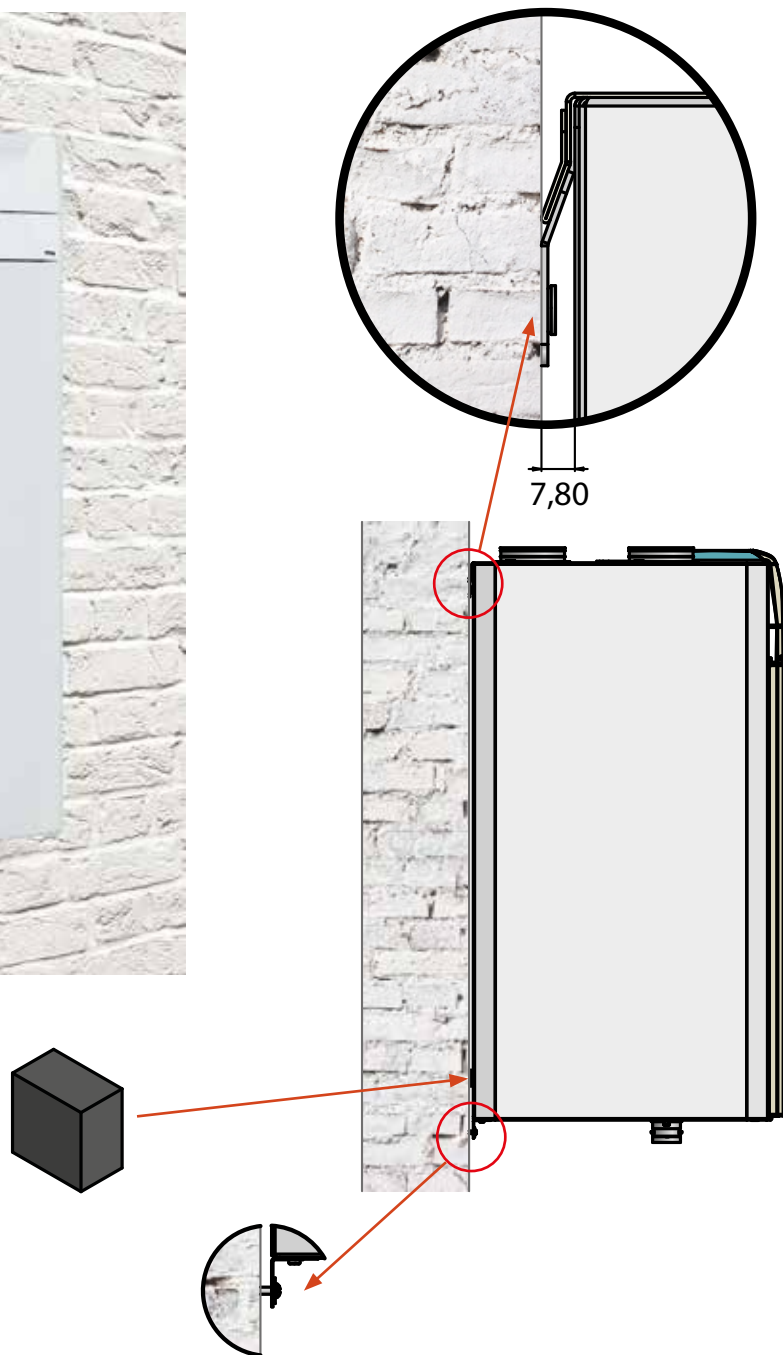

Energy Smart | Vertical Version | FLOOR INSTALLATION



ENY-S and ENY-SP units can also be installed on the floor using the special feet, available as an accessory. It is recommended to use these feet to prevent any damage to the underside of the machine (the unit cannot be placed directly on the floor) and to install the drainage siphon. Using the feet raises the unit by about 20-23 cm from the floor. The siphon is mandatory but is not provided by Sabiana.

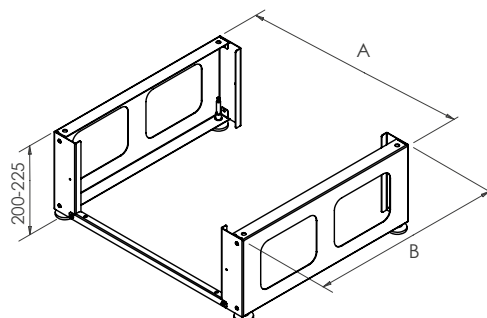
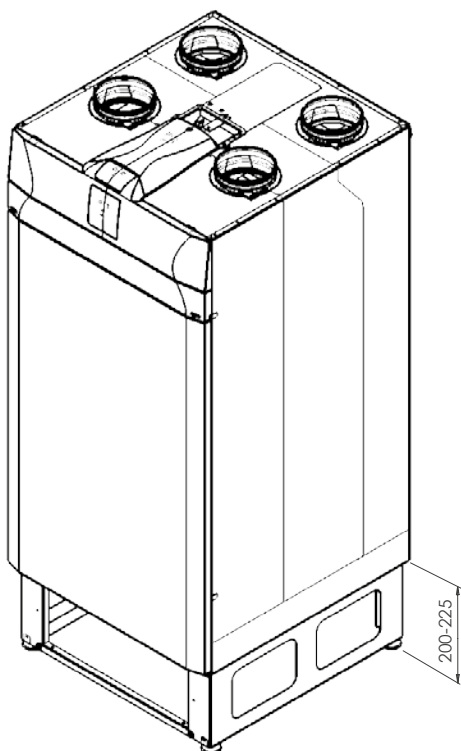
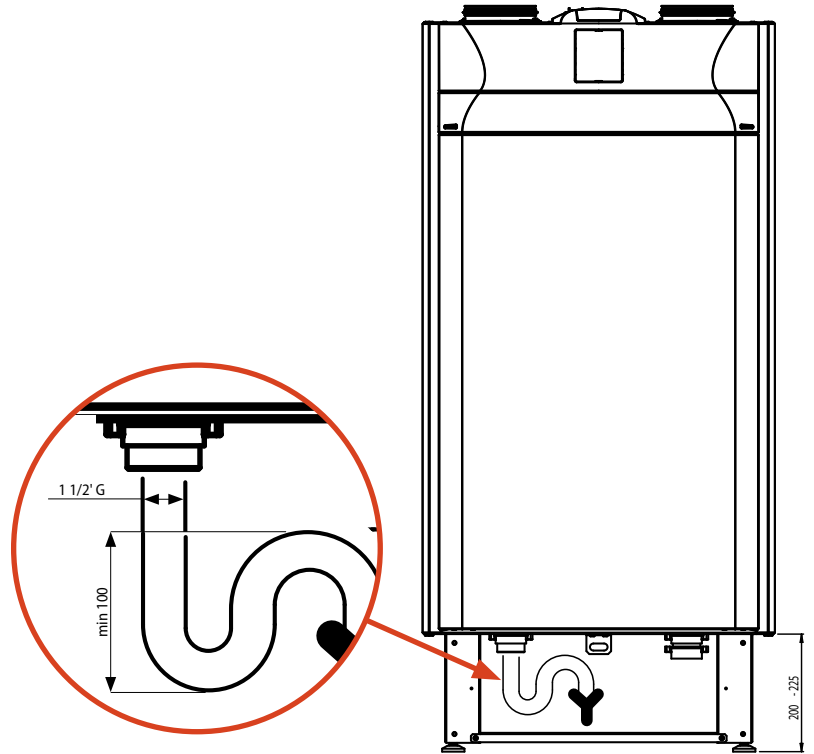

ENY-SP and ENY-S vertical version

Model	A	B
ENY-SP-180	523	534
ENY-SP-280	523	584
ENY-SP-370	583	634
ENY-SP-460	583	634
ENY-SP-600	583	634
ENY-S-170	523	549
ENY-S-270	523	534
ENY-S-360	523	584
ENY-S-460	583	634
ENY-S-600	583	634

Pro ENY-SP version with advanced air flow control



Model		ENY-SP-180	ENY-SP-280	ENY-SP-370	ENY-SP-460	ENY-SP-600*	
Depth	mm	580	630	680	680	680	
Width	mm	600	600	660	660	660	
Height	mm	1041	1041	980	980	980	
Duct connection	-	DN125	DN160	DN160	DN180	DN180	
Weight ¹	kg	47	51	56	59	60	
Maximum flow rate	m ³ /h	180	280	370	460	600	
External static pressure at maximum flow rate	Pa	100	100	100	100	100	
Reference flow rate	m ³ /h	130	200	260	320	420	
External static pressure at reference flow rate	Pa	50	50	50	50	50	
Minimum flow rate	m ³ /h	50	70	50	90	100	
Maximum external static pressure	Pa	160	240	390	400	450	
Thermal efficiency at reference flow rate EN 13141-7	%	91%	91%	92%	89%	88%	
Filtering efficiency ISO 16980	-	ePM ₁ 55% - F7 supply / ePM ₁₀ 50% - M5 extraction					
Fan type	-	Centrifugal fan with EC brushless motor and backward-curved blades					
Maximum power absorbed by controls and fans	W	50	70	120	215	300	
Maximum current absorbed by controls and fans	A	0,6	1,0	1,0	2,0	2,2	
Power supply	-	Single phase -230 V – 50 Hz via 1.5m cable with Schuko CEE 7/7 connection					
Standby power		< 1 W					
Safety features		• IP protection rating: IP21		• CE compliance ²			
Components and general materials	-	<ul style="list-style-type: none"> • T-EP capacitive touch pad integrated control • Main power board with Modbus interface • Main structure: Polystyrene • External covering: Painted galvanized steel plate • Plastic components: ABS • Acoustic insulation: Polyester fibre • Recovery unit: Counterflow plate heat recovery unit - PET 			<ul style="list-style-type: none"> • Fan blades and housings: PA6 in plastic, reinforced fibreglass • Filters: Micro-pleated type - Synthetic • Motorised bypass dampers: <ol style="list-style-type: none"> 1) ON/OFF - ABS 2) ON/OFF - Steel plate • Temperature sensors PT1000 • Humidity Sensor Central Demand Control for Extract Air • Condensate Drainage 1"½ gas thread Male 		
Accessories	-	• Feet		• External Electric Heater			
Maximum Defrost Pre-Heater power	W	500	900	1250	1600	2000	
Maximum electric heater current	A	3	5	7	9,2	10	

* = not Passivhaus certified unit

¹ Without packaging

² EN 60335-1, EN 60335-2-80, EN 62233, EN 55014-1, EN 55014-2, EN 61000-3-2, EN 61000-3-3, EN 50581, Reg. 1253/14, Reg. 1254/14 (EU Directives: 2014/35/EU, 2014/30/EU, 2006/42/EU, 2011/65/EU)

Standard ENY-S version with programmed timing profile control

Model		ENY-S-170	ENY-S-270	ENY-S-360	ENY-S-460	ENY-S-600	
Depth	mm	505	580	630	680	680	
Width	mm	547	547	547	660	660	
Height	mm	1041	1041	1041	980	980	
Duct connection	-	DN125	DN160	DN160	DN180	DN180	
Weight ¹	kg	40	48	50	59	60	
Maximum flow rate	m ³ /h	170	270	360	460	600	
External static pressure at maximum flow rate	Pa	100	100	100	100	100	
Reference flow rate	m ³ /h	120	190	250	320	420	
External static pressure at reference flow rate	Pa	50	50	50	50	50	
Minimum flow rate	m ³ /h	60	70	90	90	100	
Maximum external static pressure	Pa	250	250	350	400	450	
Thermal efficiency at reference flow rate EN 13141-7	%	87%	87%	90%	89%	88%	
Filtering efficiency ISO 16890	-	ePM ₁ 55% - F7 supply / ePM ₁₀ 50% - M5 extraction					
Fan type	-	Centrifugal fan with EC brushless motor and backward-curved blades					
Maximum power absorbed by controls and fans	W	50	80	125	215	300	
Maximum current absorbed by controls and fans	A	0,6	1,1	1,5	2,0	2,2	
Power supply	-	Single phase -230 V – 50 Hz via 1.5m cable with Schuko CEE 7/7 connection					
Standby power		< 1 W					
Safety features		• IP protection rating: IP21		• CE compliance ²			
Components and general materials	-	<ul style="list-style-type: none"> • T-EP capacitive touch pad fitted control • Main unit control board with Modbus interface • Main structure: Polystyrene • External covering and linings: Painted galvanized steel plate • Plastic components: ABS • Recovery unit: Counterflow plate heat recovery unit - PET 			<ul style="list-style-type: none"> • Fan blades and housings: ABS • Filters: Micro-pleated type - Synthetic • Motorised bypass dampers: <ol style="list-style-type: none"> 1) ON/OFF - ABS 2) ON/OFF - Steel plate • Temperature sensors PT1000 • Condensate Drainage 1"½ gas thread Male 		
Accessories	-	<ul style="list-style-type: none"> • Internal hot filament electric defrosting pre-heater with reinforced metal lining, controlled by PWM signal • Differential pressure sensor for automatic flow rate control 			<ul style="list-style-type: none"> • External Electric Heater • Feet • Humidity sensor 		
Maximum Defrost Pre-Heater power	W	500	900	1250	1600	2000	
Maximum electric heater current	A	3	5	7	9,2	10	

¹ Without packaging

² EN 60335-1, EN 60335-2-80, EN 62233, EN 55014-1, EN 55014-2, EN 61000-3-2, EN 61000-3-3, EN 50581, Reg. 1253/14, Reg. 1254/14 (EU Directives: 2014/35/EU, 2014/30/EU, 2006/42/EU, 2011/65/EU)

ENY-SP and ENY-S Versions - Construction features of the main components

1 ENY-SP version external structure

made of hot-dip galvanised steel sheet panels painted in RAL 9003 and satin finish obtained with epoxy paint dried in oven at 180 °C; the side panels are insulated with a 25 mm thick padding, while the inspection cover is completely removable and is insulated with a 30 mm thick padding.

ENY-S version external structure

made of hot-dip galvanised steel sheet panels painted in RAL 9003 and satin finish obtained with epoxy paint dried in oven at 180 °C; the inspection cover is completely removable and is insulated with a 30 mm thick padding.

2 EPDM fan access closure

3 Polyethylene EPE filter access closure

4 Electric defrosting pre-heater

Hot filament electric heater with reinforced metal lining, controlled by PWM signal (only versions with integrated electric heater).

5 High efficiency filters compliant with Standard ISO 16890;

The filters have the following features:

- ePM₁ 55% - F7 class for the supply air;
- ePM₁₀ 50% - M5 class for the extract air.

6 ABS air distribution connections for inlet/outlet air flows

7/11 Extract air (7) and air supply (11) electric fan

consisting of:

- Permanent single-phase **synchronous EC** motor.
- **High efficiency ABS fans** with backward-curved blades.
- **ABS Motor/fan housing.**

8 High efficiency static heat recovery unit

with PET counterflow exchange plates. The reachable efficiency obtainable may be higher than 90% because they ensure counterflow heat transfer between two air flows at different inlet temperatures. The static heat recovery units do not feature moving parts and guarantee high reliability and safe operation.

In order to increase the efficiency of the heat exchanger, the plate surfaces feature special swirlers.

9 Main by-pass damper

made entirely of ABS and motorised with a Valemo actuator.

10 Secondary by-pass damper

consisting of a steel blade and motorised with a Valemo actuator.

12 T-EP control

ENY-SP and ENY-S Versions

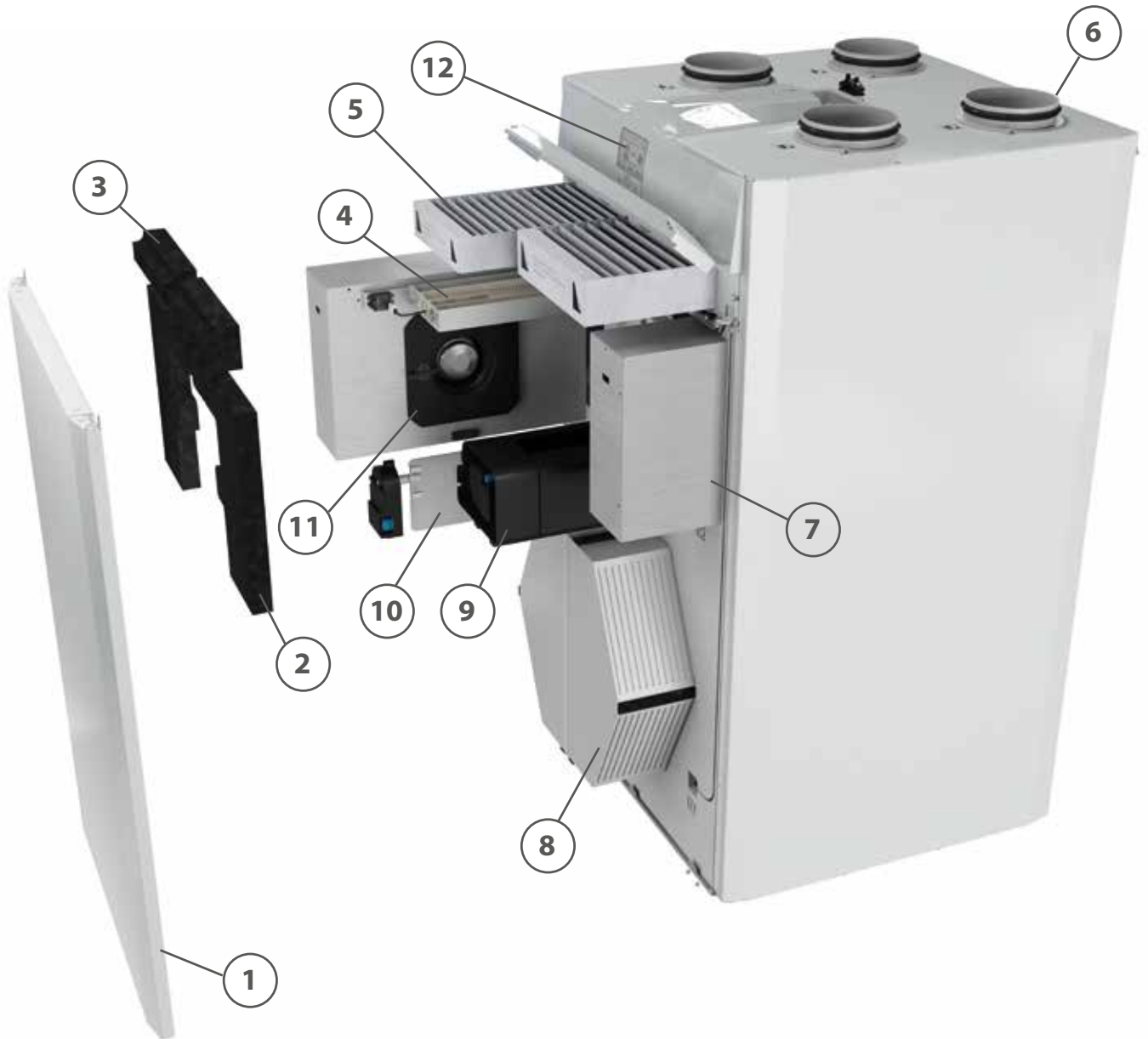

The units are configured with the fresh air fan on the front left side and that of the extracted air on the right side. If necessary, it is possible to invert the flows by inverting the position of the filters, the position of the condensate drain, the position of the humidity probe (ENY-SP versions only) and paying attention to the proper connection of the ducts to the machine; below is the standard configuration and the inverted flow configuration

**LEFT SIDE CONFIGURATION
DEFAULT**

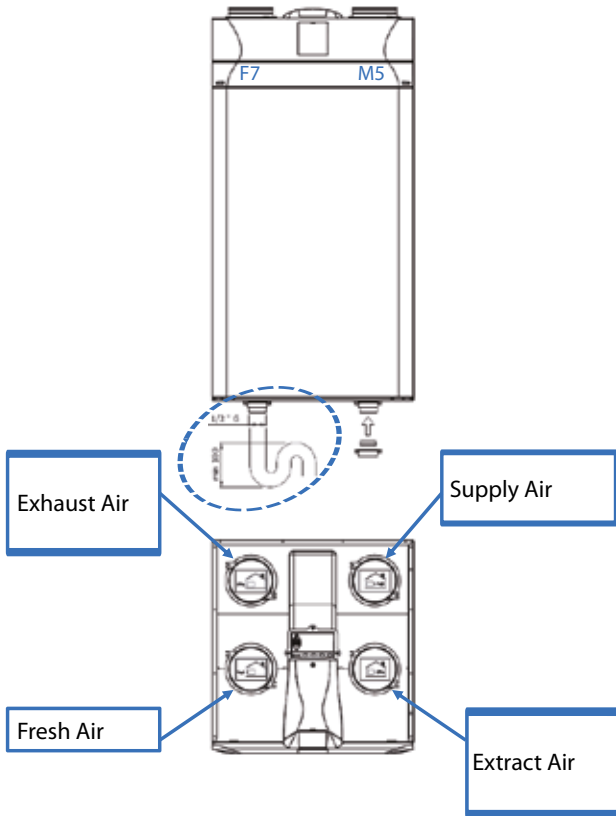

**RIGHT SIDE CONFIGURATION
OPTIONAL**

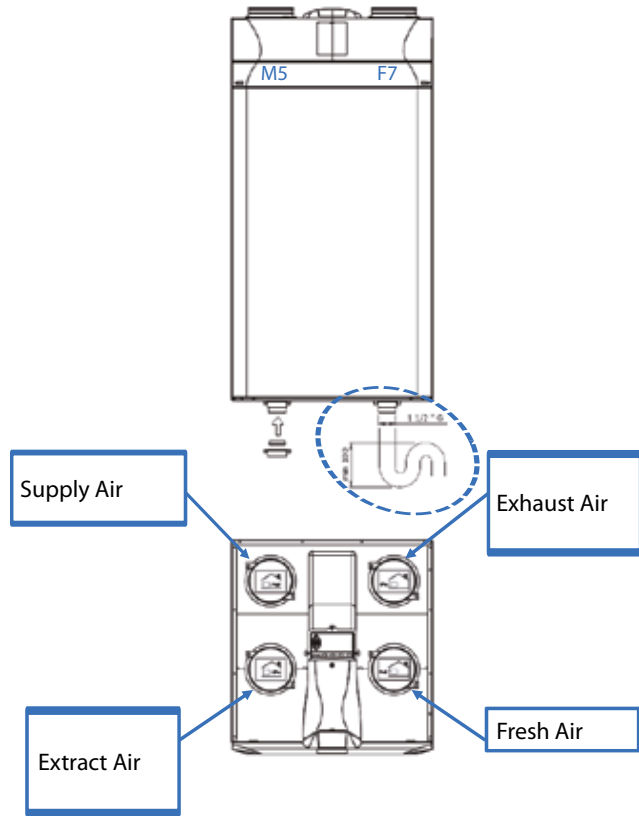

DIAGRAM

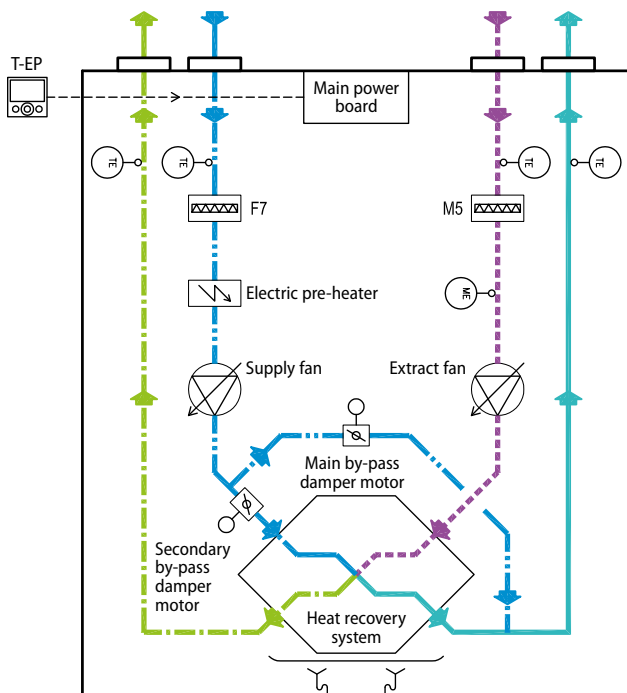

LEGEND

	Fresh air
	Supply air
	Extract air
	Exhaust air
	Micro pleat filter
	Remote or on board control
	Electric pre-heater optional only required for cold climates
	Temperature sensor
	Humidity Sensor Central Demand Control
	Condensate Drainage

The thermal performance shown below was measured in compliance with Standard EN 13141-7, recommended by the European Commission documents enclosed in EU Regulation 1253-14. The conditions relating to the performance are the following:

- fresh air temperature= 7 °C
- indoor air temperature= 20 °C
- internal relative humidity = 45%

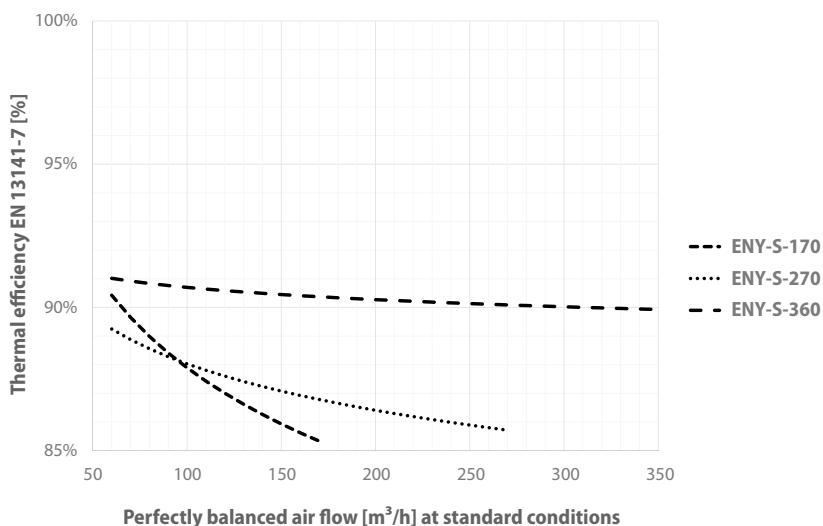
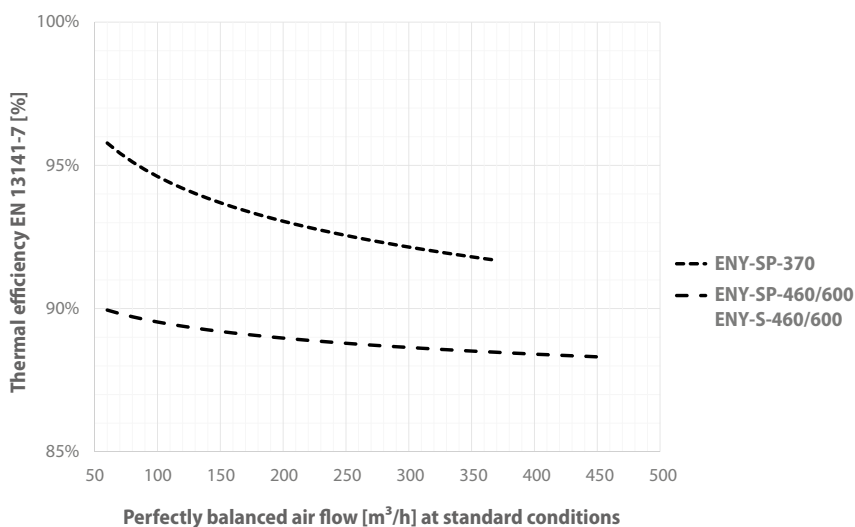
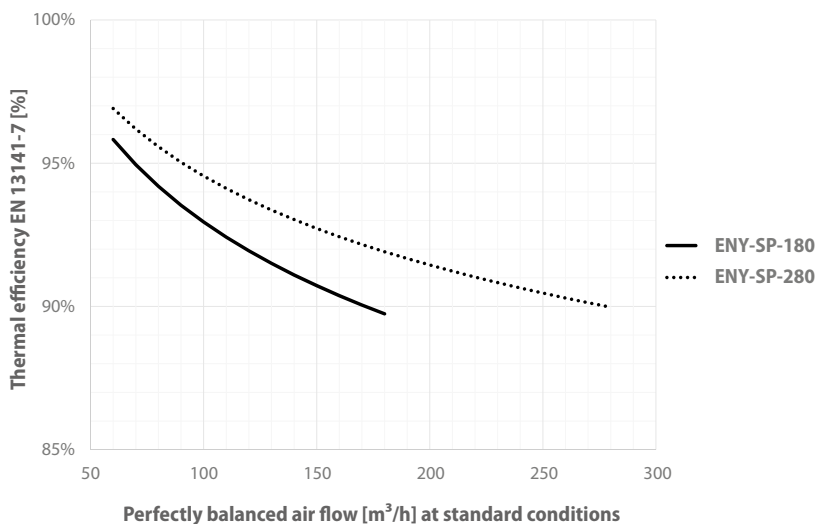

ENY-SP-180

All mechanical efficiency curves are measured in standard air conditions (1 atm, 20 °C)

- Nominal flow rate range $V_{max} = 9.6 \text{ V}$; $V_{min} = 4.2 \text{ V}$
- Maximum current input $I_{max} = 0.6 \text{ A}$ at 10 V

Supply air

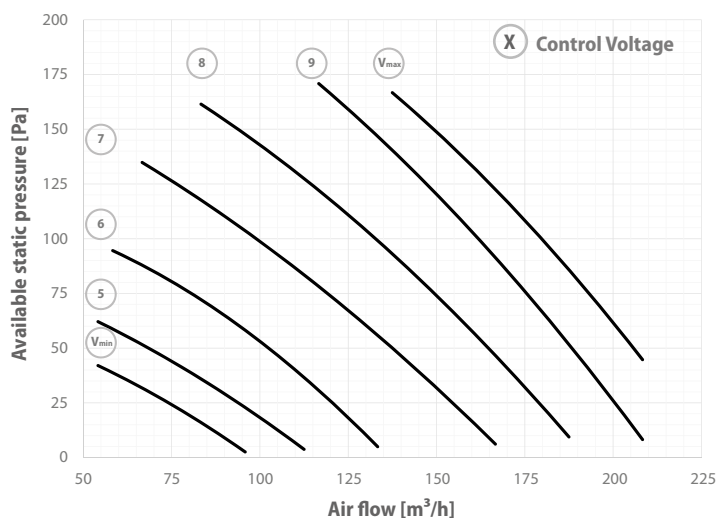

Extract air

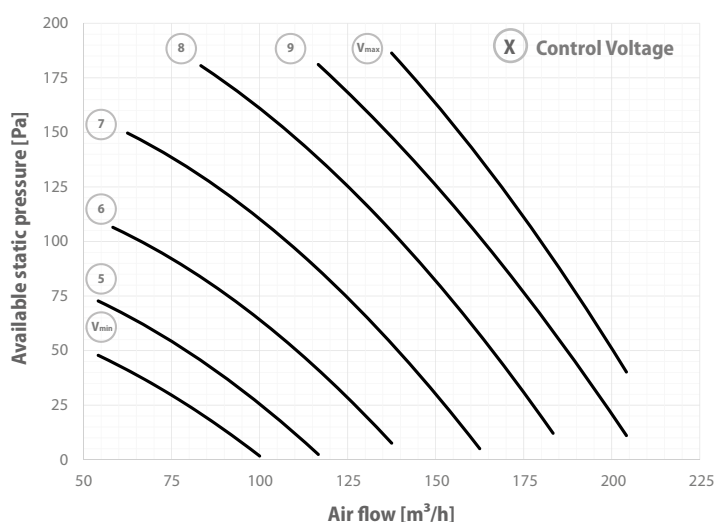

Specific fan power - SFP

SFP includes the consumption of the fans and controls. The curves apply in the event of balanced flow rates.

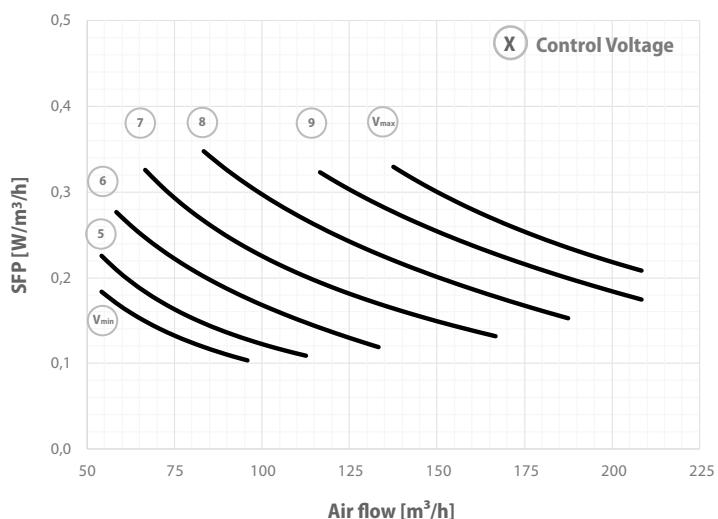

The minimum voltage indicated only refers to a minimum value that can be configured during the nominal flow rate calibration procedure. In fact, during normal operation the motors can operate at lower voltages.

ENY-SP-280

All mechanical efficiency curves are measured in standard air conditions (1 atm, 20 °C).

- Nominal flow rate range $V_{max} = 8,0 V$; $V_{min} = 4,5 V$.
- Maximum current input $I_{max} = 1,0 A$ a $10 V$.

Supply air

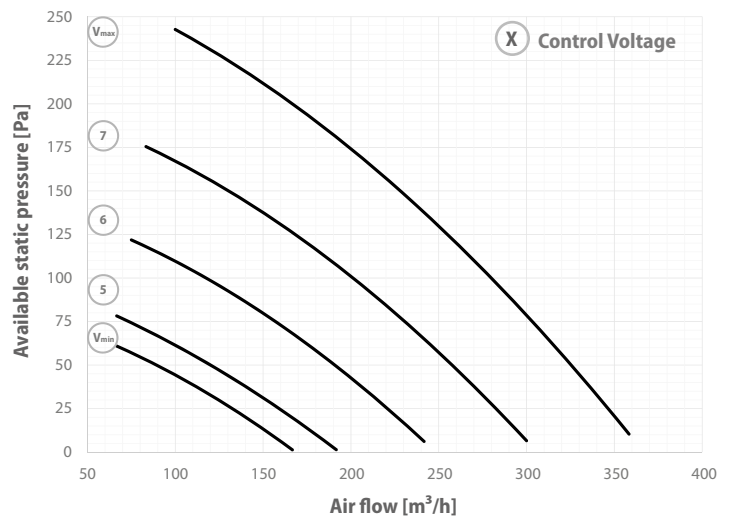

Extract air

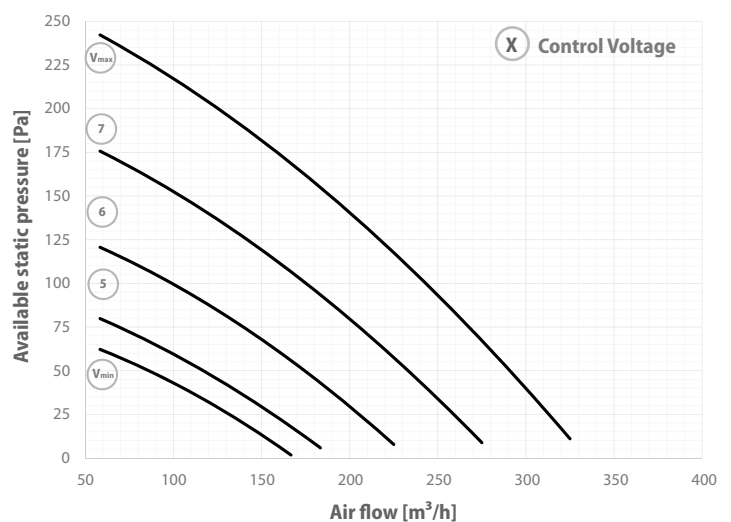

Specific fan power - SFP

SFP includes the consumption of the fans and controls. The curves apply in the event of balanced flow rates.

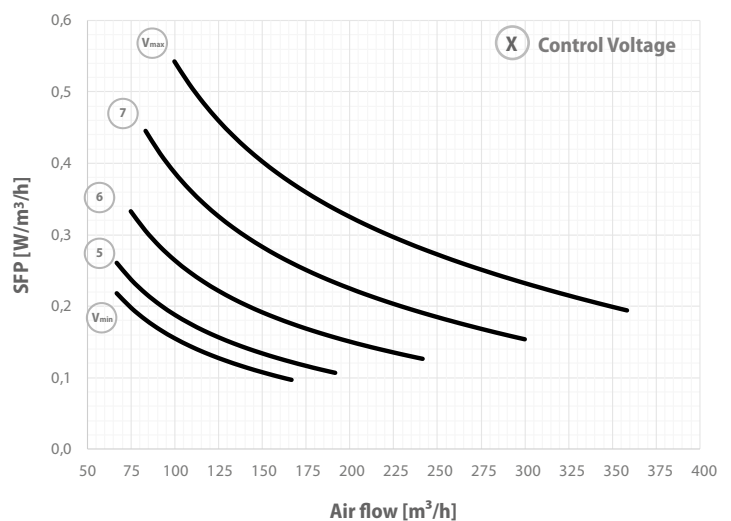

The minimum voltage indicated only refers to a minimum value that can be configured during the nominal flow rate calibration procedure. In fact, during normal operation the motors can operate at lower voltages.

ENY-SP-370

All mechanical efficiency curves are measured in standard air conditions (1 atm, 20 °C).

- Nominal flow rate range $V_{max} = 10,0 V$; $V_{min} = 4,0 V$.
- Maximum current input $I_{max} = 1,0 A$ a $10 V$.

Supply air

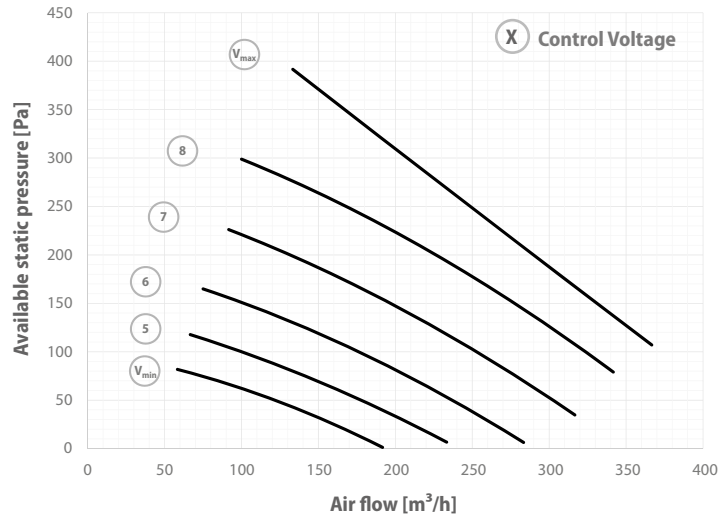

Extract air

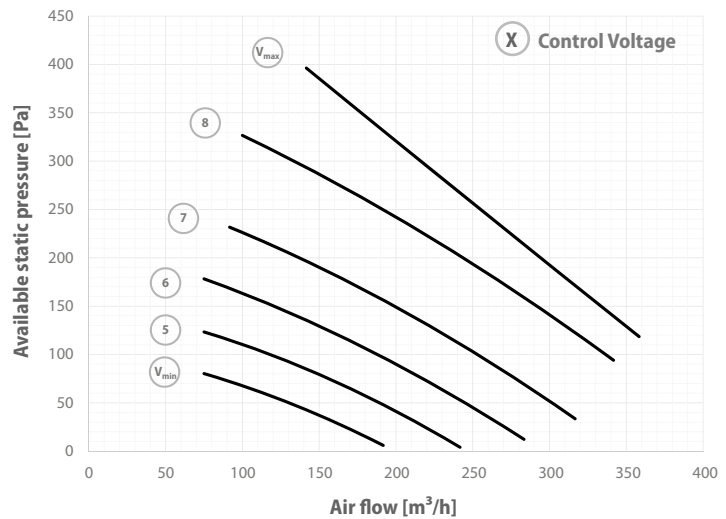

Specific fan power - SFP

SFP includes the consumption of the fans and controls. The curves apply in the event of balanced flow rates.

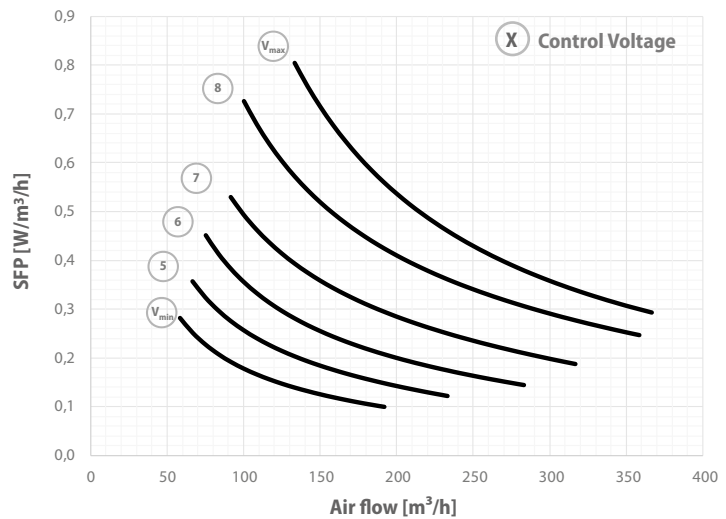

The minimum voltage indicated only refers to a minimum value that can be configured during the nominal flow rate calibration procedure. In fact, during normal operation the motors can operate at lower voltages.

ENY-SP-460

All mechanical efficiency curves are measured in standard air conditions (1 atm, 20 °C).

- Nominal flow rate range $V_{max} = 7,0 V$; $V_{min} = 3,2 V$.
- Maximum current input $I_{max} = 2,0 A$ a $10 V$.

Supply air

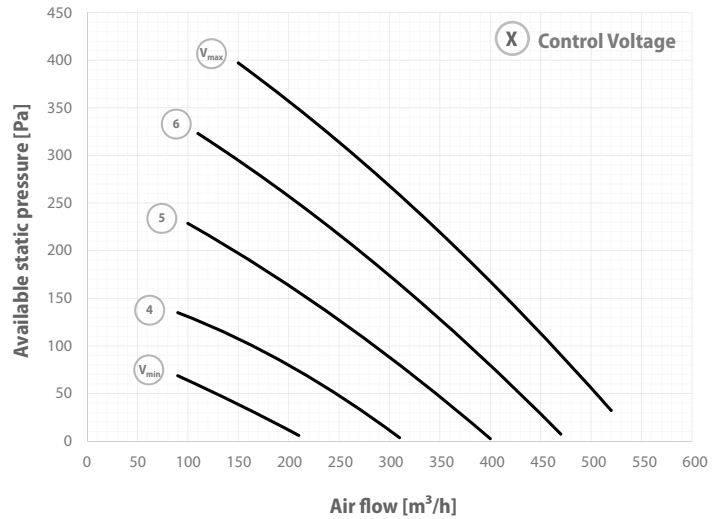

Extract air

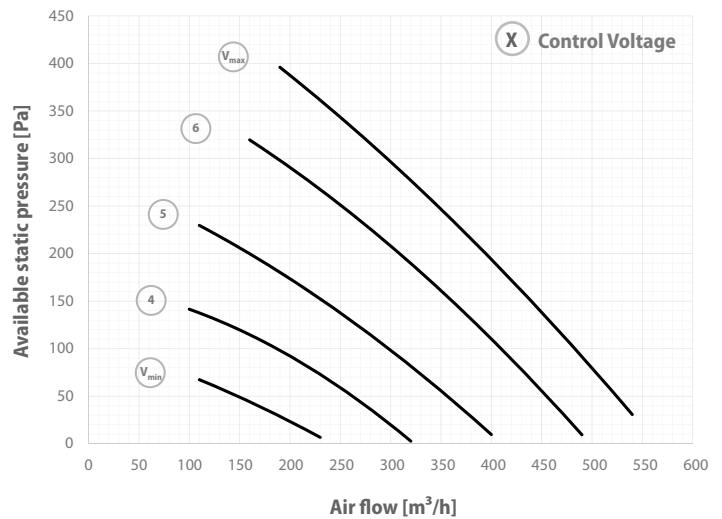

Specific fan power - SFP

SFP includes the consumption of the fans and controls. The curves apply in the event of balanced flow rates.

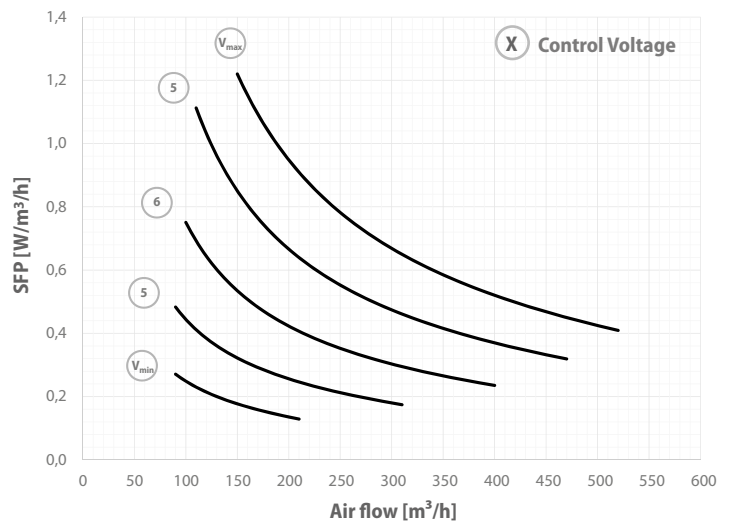

The minimum voltage indicated only refers to a minimum value that can be configured during the nominal flow rate calibration procedure. In fact, during normal operation the motors can operate at lower voltages.

ENY-SP-600

All mechanical efficiency curves are measured in standard air conditions (1 atm, 20 °C).

- Nominal flow rate range $V_{max} = 8 V$; $V_{min} = 3,4 V$.
- Maximum current input $I_{max} = 3,0 A$ a $10 V$.

Supply air

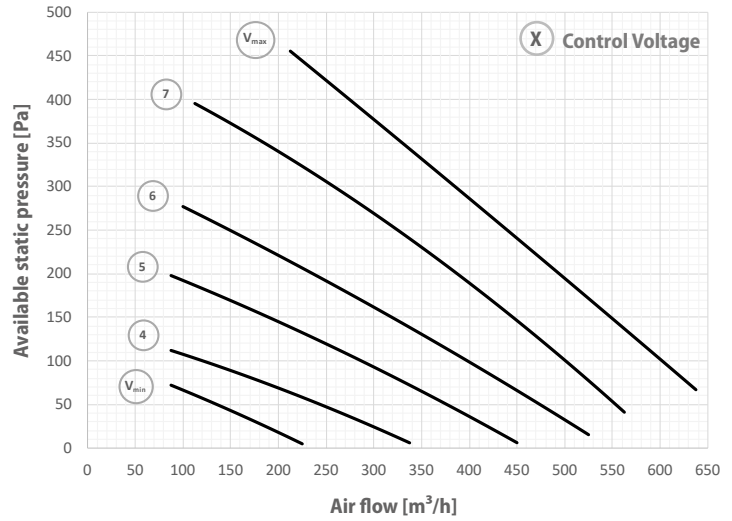

Extract air

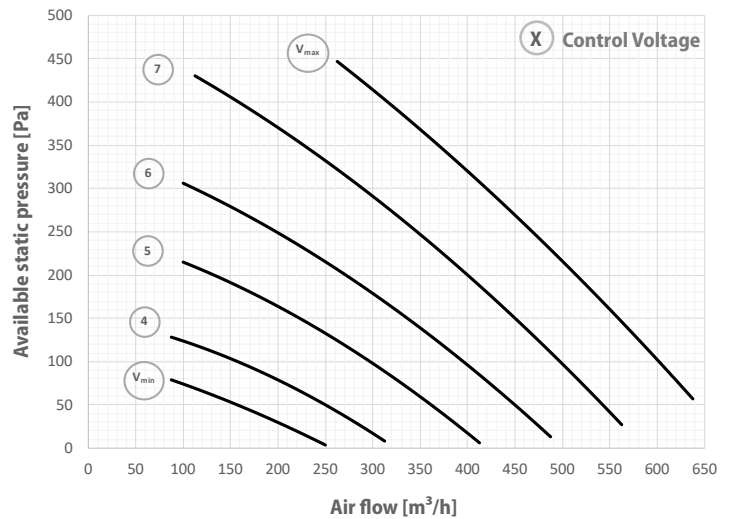

Specific fan power - SFP

SFP includes the consumption of the fans and controls. The curves apply in the event of balanced flow rates.

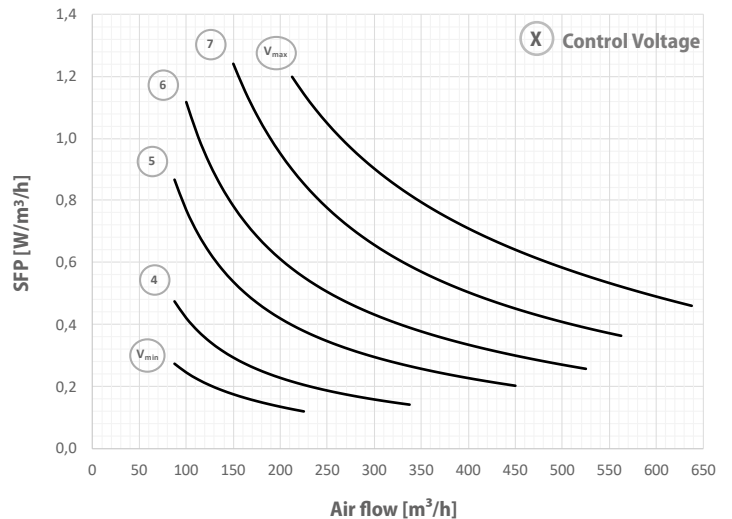

The minimum voltage indicated only refers to a minimum value that can be configured during the nominal flow rate calibration procedure. In fact, during normal operation the motors can operate at lower voltages.

ENY-S-170

All mechanical efficiency curves are measured in standard air conditions (1 atm, 20 °C).

- Nominal flow rate range $V_{max} = 9,0 V$; $V_{min} = 4,0 V$.
- Maximum current input $I_{max} = 0,6 A$ a 10 V.

Supply air

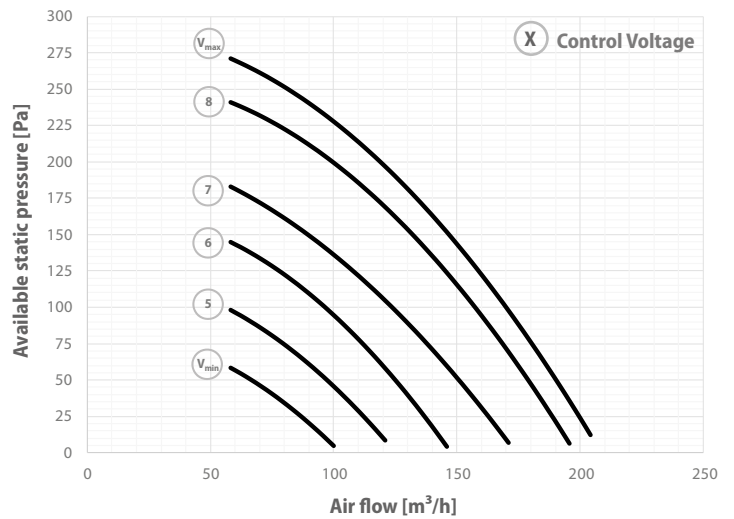

Extract air

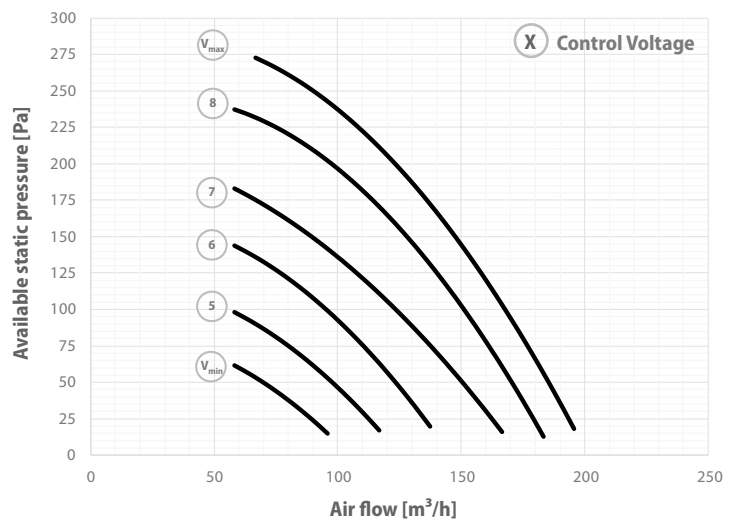

Specific fan power - SFP

SFP includes the consumption of the fans and controls. The curves apply in the event of balanced flow rates.

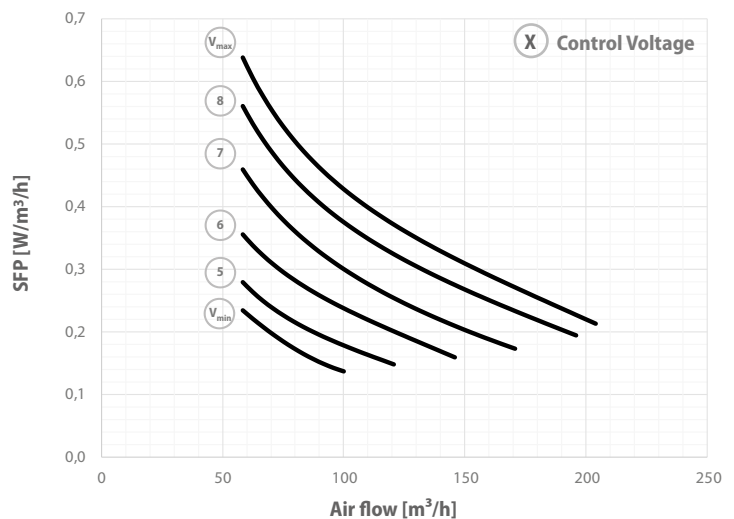

The minimum voltage indicated only refers to a minimum value that can be configured during the nominal flow rate calibration procedure. In fact, during normal operation the motors can operate at lower voltages.

ENY-S-270

All mechanical efficiency curves are measured in standard air conditions (1 atm, 20 °C).

- Nominal flow rate range $V_{max} = 8,0 V$; $V_{min} = 3,5 V$.
- Maximum current input $I_{max} = 1,0 A$ a $10 V$.

Supply air

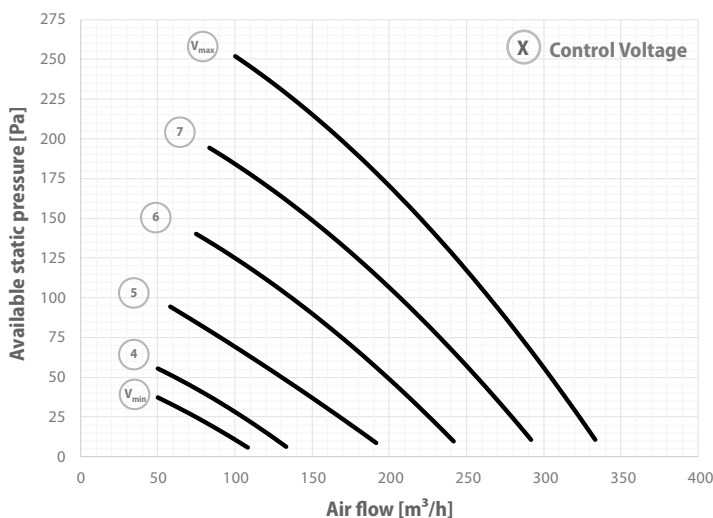

Extract air

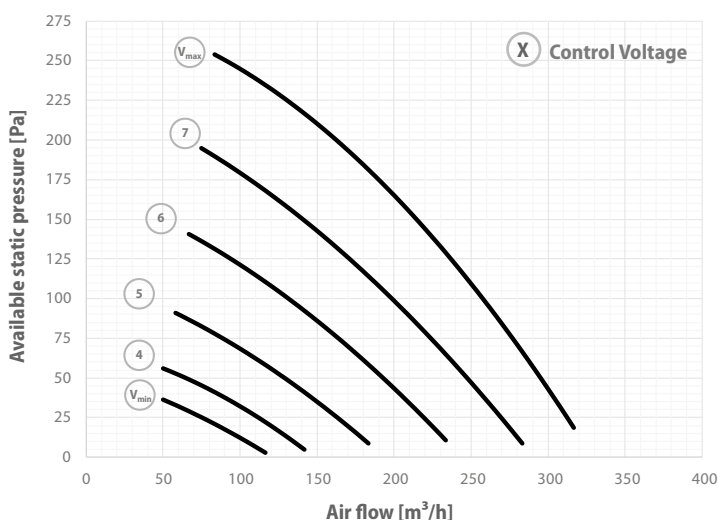

Specific fan power - SFP

SFP includes the consumption of the fans and controls. The curves apply in the event of balanced flow rates.

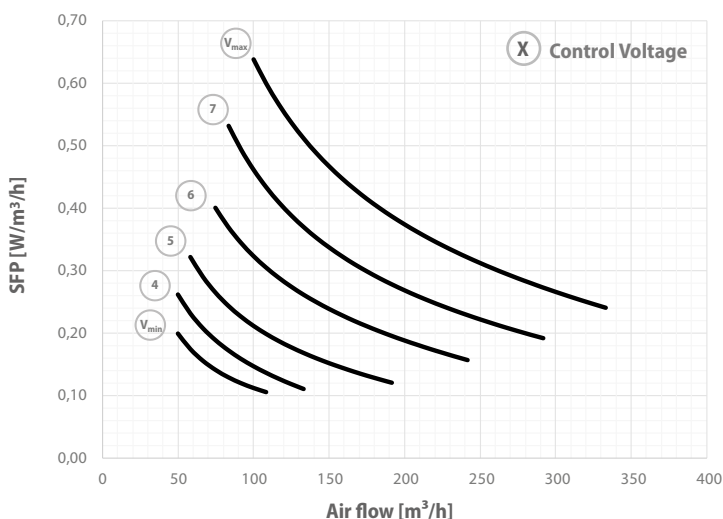

The minimum voltage indicated only refers to a minimum value that can be configured during the nominal flow rate calibration procedure. In fact, during normal operation the motors can operate at lower voltages.

ENY-S-360

All mechanical efficiency curves are measured in standard air conditions (1 atm, 20 °C).

- Nominal flow rate range $V_{max} = 7,0 V$; $V_{min} = 3,0 V$.
- Maximum current input $I_{max} = 1,4 A$ a 10 V.

Supply air

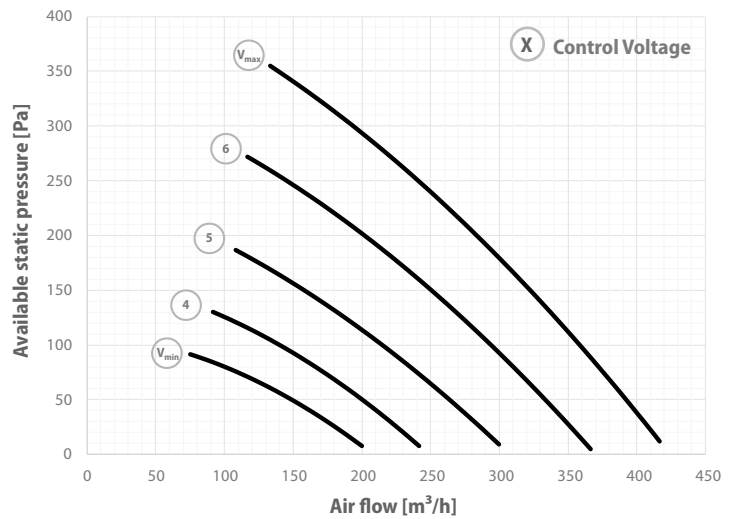

Extract air

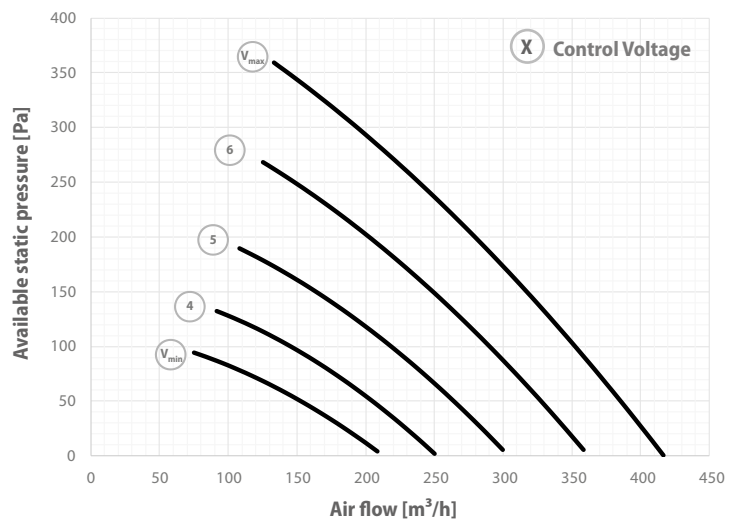

Specific fan power - SFP

SFP includes the consumption of the fans and controls. The curves apply in the event of balanced flow rates.

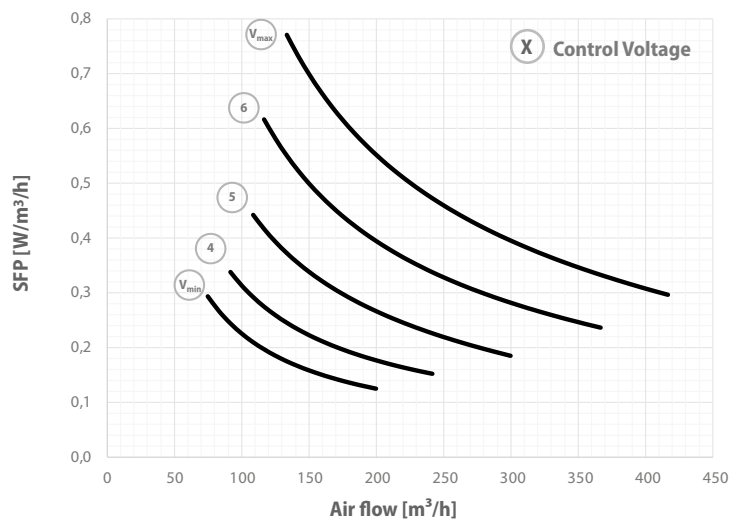

The minimum voltage indicated only refers to a minimum value that can be configured during the nominal flow rate calibration procedure. In fact, during normal operation the motors can operate at lower voltages.

ENY-S-460

All mechanical efficiency curves are measured in standard air conditions (1 atm, 20 °C).

- Nominal flow rate range $V_{max} = 7,0 V$; $V_{min} = 3,2 V$.
- Maximum current input $I_{max} = 2,0 A$ a $10 V$.

Supply air

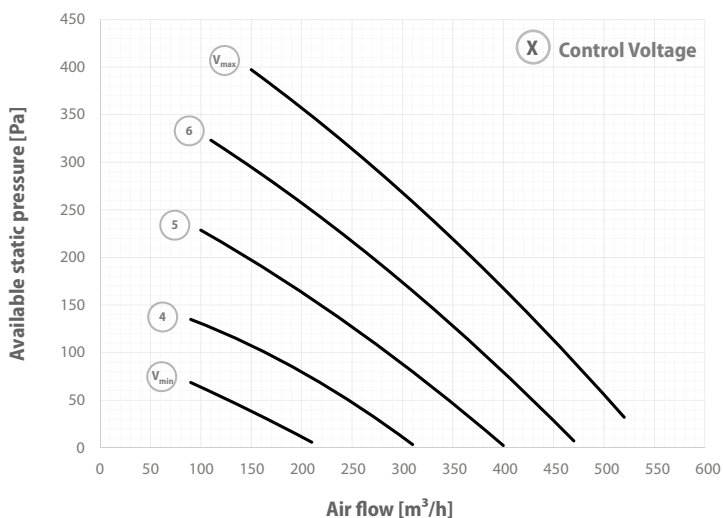

Extract air

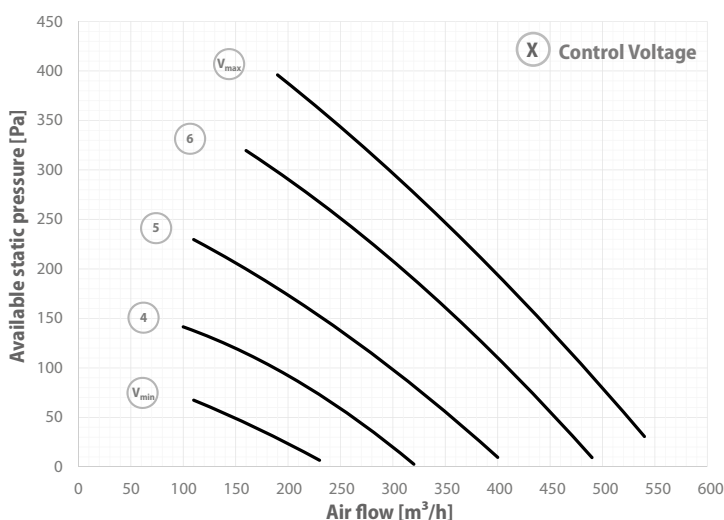

Specific fan power - SFP

SFP includes the consumption of the fans and controls. The curves apply in the event of balanced flow rates.

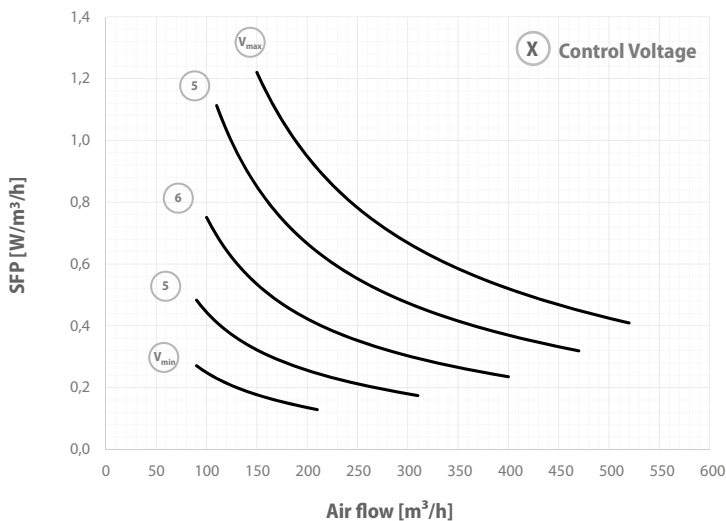

The minimum voltage indicated only refers to a minimum value that can be configured during the nominal flow rate calibration procedure. In fact, during normal operation the motors can operate at lower voltages.

ENY-S-600

All mechanical efficiency curves are measured in standard air conditions (1 atm, 20 °C).

- Nominal flow rate range $V_{max} = 8 V$; $V_{min} = 3,4 V$.
- Maximum current input $I_{max} = 3,0 A$ a 10 V.

Supply air

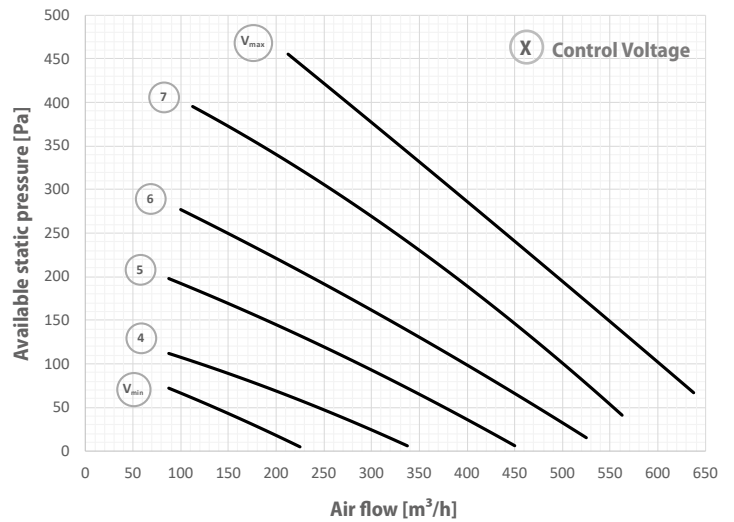

Extract air

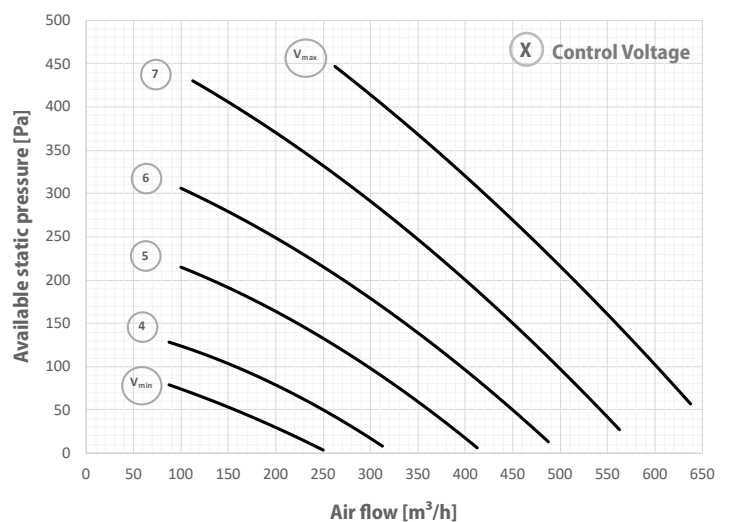

Specific fan power - SFP

SFP includes the consumption of the fans and controls. The curves apply in the event of balanced flow rates.

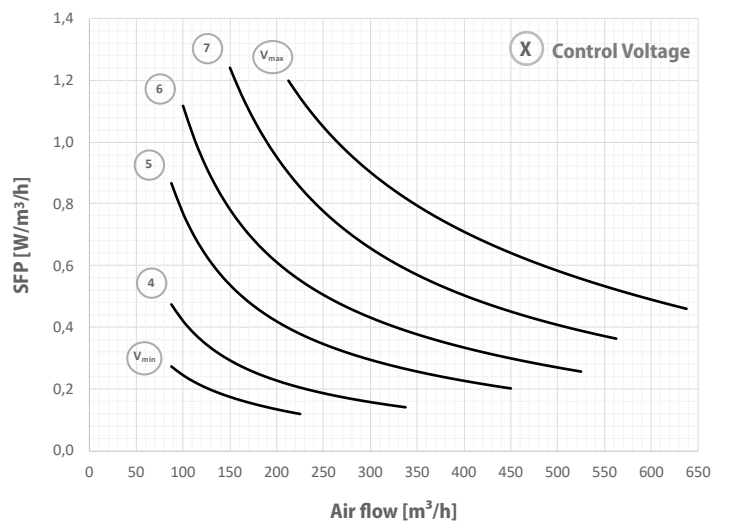

The minimum voltage indicated only refers to a minimum value that can be configured during the nominal flow rate calibration procedure. In fact, during normal operation the motors can operate at lower voltages.

ENY-SHP-150 Pro Version

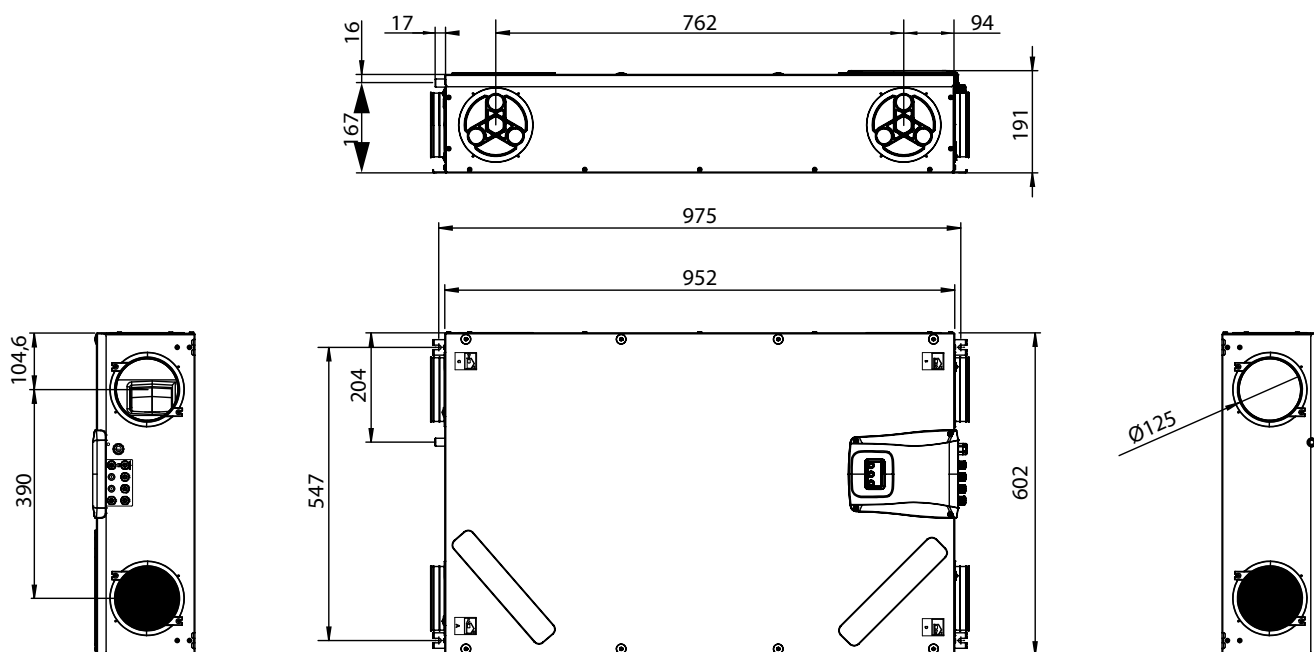

	Weight with packaging	Weight without packaging
ENY-SHP-150	25 kg	23 kg

INSTALLATION

The ENY-SHP-150 unit can easily be installed both horizontally and vertically. Special support brackets pre-fitted on the unit are provided to install the unit horizontally on the ceiling and to install the unit vertically (especially in gaps between plasterboard walls and load-bearing walls).

Horizontal installation

Spacer bars can be used to adjust the distance from the ceiling. It is recommended to install the unit tilted towards the side where the ePM₁ 55% - F7 filter is placed, in order to facilitate condensate drainage. Provide a slope of min. 5 mm towards the condensate drain.

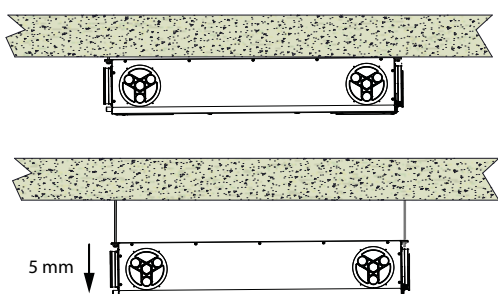

Vertical installation

Place the unit with the touch screen control upwards, so that the condensate drain connection remains downwards.

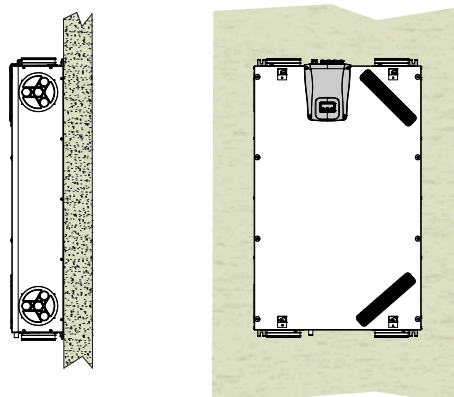

The instruction manual indicates the appropriate maintenance clearance for each type of installation.

ENY-SHP-170 Pro Version

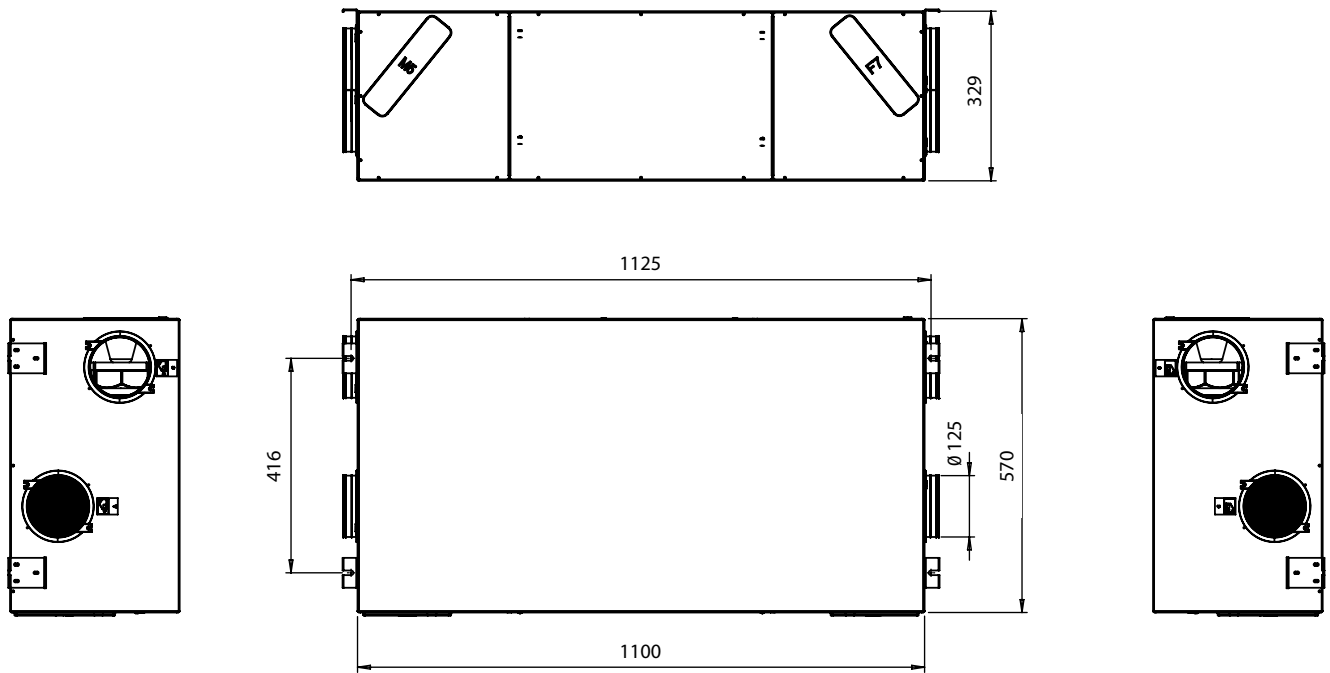

	Weight with packaging	Weight without packaging
ENY-SHP-170	35 kg	31 kg

INSTALLATION

The ENY-SHP-170 unit can easily be installed both horizontally and vertically. Special support brackets are provided to install the unit horizontally on the ceiling and to install the unit vertically (especially in gaps between plasterboard walls and load-bearing walls).

Horizontal installation

Spacer bars can be used to adjust the distance from the ceiling. It is recommended to install the unit tilted towards the side where the ePM₁ 55% - F7 filter and the condensate drain pipe are placed, in order to facilitate condensate drainage (provide a slope of 2% towards the filter and of 1% towards the condensate drain pipe).

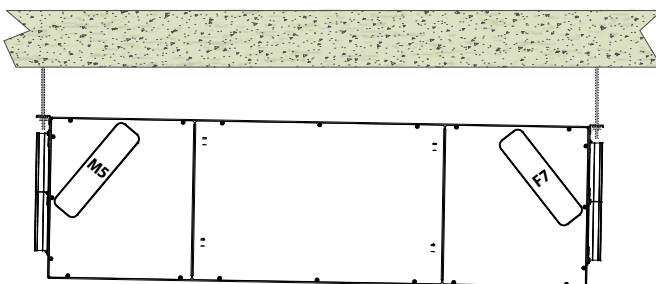

Vertical installation

Place the side ePM₁ 55% - F7 downwards the unit.

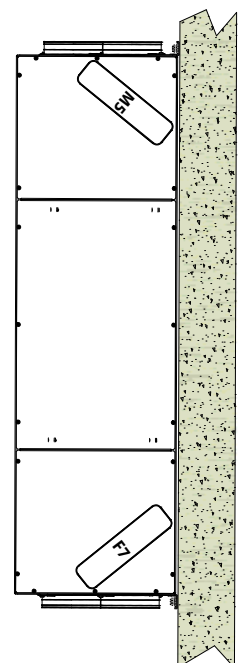

The instruction manual indicates the appropriate maintenance clearance for each type of installation.

ENY-SHP-270 Pro Version

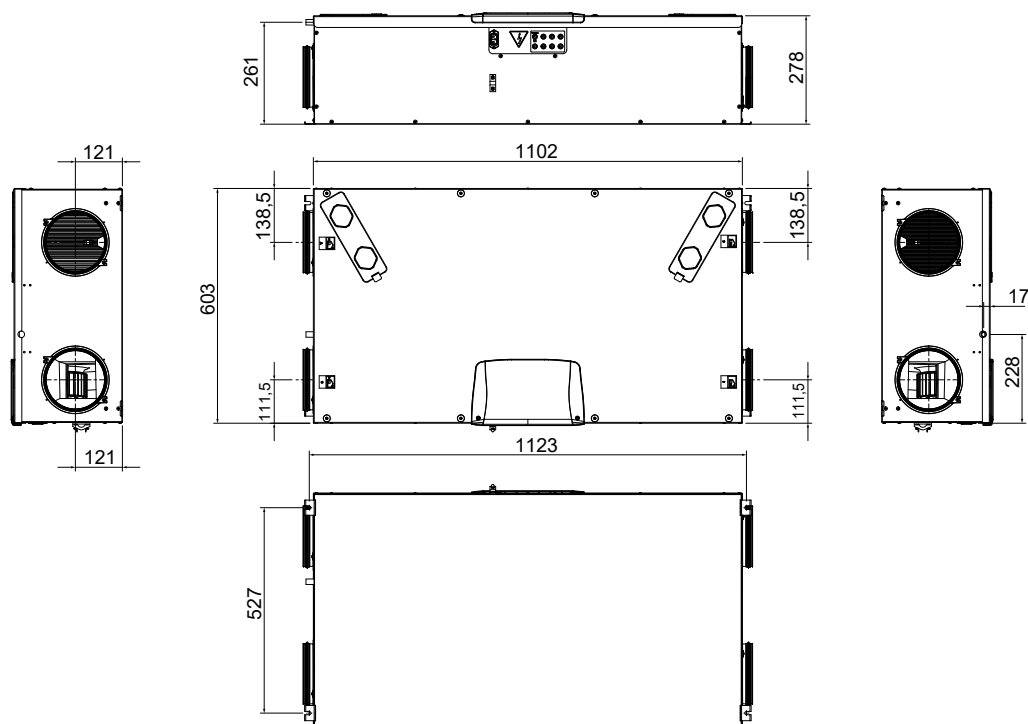

	Weight with packaging	Weight without packaging
ENY-SHP-270	38 kg	31 kg

INSTALLATION

The ENY-SHP-270 unit can easily be installed both horizontally and vertically. Special support brackets are provided to install the unit horizontally on the ceiling and to install the unit vertically (especially in gaps between plasterboard walls and load-bearing walls).

Horizontal installation

Spacer bars can be used to adjust the distance from the ceiling. It is recommended to install the unit tilted towards the side where the ePM₁ 55% - F7 filter and the condensate drain pipe are placed, in order to facilitate condensate drainage (provide a slope of 2% towards the filter and of 1% towards the condensate drain pipe).

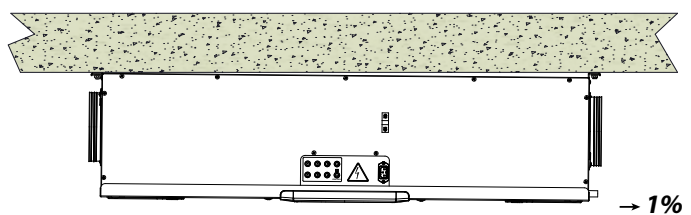

Vertical installation

Place the side ePM₁ 55% - F7 downwards the unit.

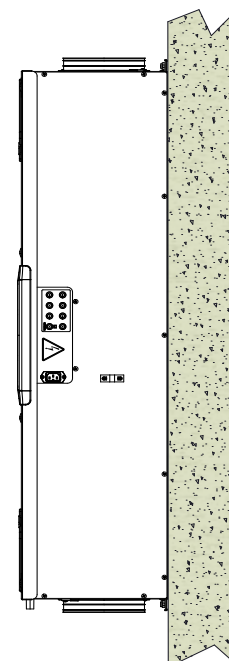

Pro ENY-SHP-150 Version with advanced air flow control

Model		ENY-SHP-150
Depth	mm	952
Width	mm	602
Height	mm	191
Duct connection	-	DN125
Weight ¹	kg	23
Maximum flow rate	m ³ /h	150
External static pressure at maximum flow rate	Pa	100
Reference flow rate	m ³ /h	105
External static pressure at reference flow rate	Pa	50
Minimum flow rate	m ³ /h	60
Maximum external static pressure	Pa	150
Thermal efficiency at reference flow rate EN 13141-7	%	87%
Filtering efficiency ISO 16890	-	ePM ₁ 55% - F7 supply / ePM ₁₀ 50% - M5 extraction
Fan type	-	Centrifugal fan with EC brushless motor and forward curved blades
Maximum power absorbed by controls and fans ³	W	59
Maximum current absorbed by controls and fans	A	0,5
Power supply	-	Single phase -230 V – 50 Hz via 1.5 m cable with Schuko CEE 7/7 connection
Standby power		< 1 W
Safety features		<ul style="list-style-type: none"> • IP protection rating: IP21 • CE compliance ²
Components and general materials	-	<ul style="list-style-type: none"> • Recovery unit: counterflow plate heat recovery unit. • Main power board with Modbus interface built-in display. • Filters: micro-pleated type - synthetic. • Main structure: polystyrene. • Temperature sensors PT1000. • External covering: painted galvanized steel plate. • Humidity Sensor Central Demand Control for Extract Air. • Condensate drain pipe L=800 mm.
Accessories	-	<ul style="list-style-type: none"> • T-EP capacitive touch pad integrated control. • External Electric Heater. • KNX bus system.
Maximum Defrost Pre-Heater power ⁴	W	600
Maximum electric heater current	A	3

1 Without packaging

2 EN 60335-1, EN 60335-2-80, EN 62233, EN 55014-1, EN 55014-2, EN 61000-3-2, EN 61000-3-3, EN 50581, Reg. 1253/14, Reg. 1254/14 (EU Directives: 2014/35/EU, 2014/30/EU, 2006/42/EU, 2011/65/EU)

3 Maximum power absorbed under ErP conditions with 100Pa maximum flow rate.

4 External electric heater (Accessory)

Pro ENY-SHP-170 Version with advanced air flow control



Model		ENY-SHP-170
Depth	mm	1098
Width	mm	568
Height	mm	327
Duct connection	-	DN125
Weight ¹	kg	31
Maximum flow rate	m ³ /h	170
External static pressure at maximum flow rate	Pa	100
Reference flow rate	m ³ /h	120
External static pressure at reference flow rate	Pa	50
Minimum flow rate	m ³ /h	60
Maximum external static pressure	Pa	230
Thermal efficiency at reference flow rate EN 13141-7	%	92%
Filtering efficiency ISO 16890	-	ePM ₁ 55% - F7 supply / ePM ₁₀ 50% - M5 extraction
Fan type	-	Centrifugal fan with EC brushless motor and backward-curved blades
Maximum power absorbed by controls and fans	W	50
Maximum current absorbed by controls and fans	A	0,6
Power supply	-	Single phase -230 V – 50 Hz via 1.5 m cable with Schuko CEE 7/7 connection
Standby power		< 1 W
Safety features		<ul style="list-style-type: none"> • IP protection rating: IP21 • CE compliance ²
Components and general materials	-	<ul style="list-style-type: none"> • T-EP capacitive touch pad integrated control . • Main power board with Modbus interface. • Maximum defrost pre-heater power: hot filament electric heater with reinforced metal lining, controlled by PWM signal (optional). • Main structure: Polystyrene. • External covering: Painted galvanized steel plate. • Recovery unit: Counterflow plate heat recovery unit - PET. • Fan blades and housings: PA6 in plastic, reinforced fibreglass • Filters: Micro-pleated type - Synthetic Bypass damper with two louvers made of POM and steel. • Temperature sensors PT1000 • Humidity Sensor Central Demand Control for Extract Air • Condensate drain pipe L=800
Accessories	-	<ul style="list-style-type: none"> • Internal hot filament Defrost Electric Pre-Heater with reinforced metal lining, controlled by PWM signal • External Electric Heater
Maximum Defrost Pre-Heater power	W	600
Maximum electric heater current	A	3

¹ Without packaging

² EN 60335-1, EN 60335-2-80, EN 62233, EN 55014-1, EN 55014-2, EN 61000-3-2, EN 61000-3-3, EN 50581, Reg. 1253/14, Reg. 1254/14 (EU Directives: 2014/35/EU, 2014/30/EU, 2006/42/EU, 2011/65/EU)

Pro ENY-SHP-270 Version with advanced air flow control

Model		ENY-SHP-270
Depth	mm	1102
Width	mm	773
Height	mm	315
Duct connection	-	160
Weight ¹	kg	31
Maximum flow rate	m ³ /h	270
External static pressure at maximum flow rate	Pa	100
Reference flow rate	m ³ /h	190
External static pressure at reference flow rate	Pa	50
Minimum flow rate	m ³ /h	88
Maximum external static pressure	Pa	200
Thermal efficiency at reference flow rate EN 13141-7	%	85,5%
Filtering efficiency ISO 16890	-	ePM ₁ 55% - F7 supply / ePM ₁₀ 50% - M5 extraction
Fan type	-	Centrifugal fan with EC brushless motor and forward curved blades
Maximum power absorbed by controls and fans	W	184
Maximum current absorbed by controls and fans	A	1,58
Power supply	-	Single phase -230 V – 50 Hz via 1.5 m cable with Schuko CEE 7/7 connection
Standby power		< 1 W
Safety features		<ul style="list-style-type: none"> • IP protection rating: IP21 • CE compliance ²
Components and general materials	-	<ul style="list-style-type: none"> • T-EP capacitive touch pad integrated control . • Main power board with Modbus interface. • Maximum defrost pre-heater power: hot filament electric heater with reinforced metal lining, controlled by PWM signal (optional). • Main structure: Polystyrene. • External covering: Painted galvanized steel plate. • Recovery unit: Counterflow plate heat recovery unit - PET. • Fan blades and housings: PA6 in plastic, reinforced fibreglass • Filters: Micro-pleated type - Synthetic • Bypass damper with louvers made of ABS and steel. • Temperature sensors NTC10k • Double humidity Sensor Central Demand Control for Supply and Extract Air • Condensate drain pipe L=800 mm
Accessories	-	<ul style="list-style-type: none"> • Internal hot filament Defrost Electric Pre-Heater with reinforced metal lining, controlled by PWM signal • External Electric Heater
Maximum Defrost Pre-Heater power	W	600
Maximum electric heater current	A	4

¹ Without packaging

² EN 60335-1, EN 60335-2-80, EN 62233, EN 55014-1, EN 55014-2, EN 61000-3-2, EN 61000-3-3, EN 50581, Reg. 1253/14, Reg. 1254/14 (EU Directives: 2014/35/EU, 2014/30/EU, 2006/42/EU, 2011/65/EU)

Pro ENY-SHP-150 Version **Construction features of the main components**

- 1 ENY-SHP-150 version external structure**
made of hot-dip galvanised steel sheet panels.
- 2 Internal structure**
made of high density Polystyrene.
- 3 Frontal panel**
galvanized, insulated and painted in RAL 9003.
- 4 Main power board**
Main power board with built-in display, easy to use for calibration and activation of the unit.
- 5 High efficiency filters compliant with standard ISO 16890**
High efficiency micro-pleated filters, frontal extraction have the following features:
 - ePM₁ 55% - F7 class for the supply air;
 - ePM₁₀ 50% - M5 class for the extract air.
- 6 ABS shanks for inlet/outlet flow connection**
- 7 Caps made of ABS for the interchangeability of the position of the air distribution inlet/outlet connections.**
- 8 Extract air and air supply electric fan**
high efficiency centrifugal fan with EC brushless motor and forward curved blades, steady control of air flow rate.
- 9 Static recovery unit**
Counterflow heat recovery unit with low pressure drops. It prevents any winter heat drops due to the introduction of fresh air, thereby recovering up to 88% of the extract heat.
The static heat recovery units do not feature moving parts and guarantee high reliability and safe operation.
- 10 Condensate collection tray**
The condensate collection tray made of ABS is designed for the correct condensate drain in every type of installations, ceiling or wall ones.
- 11 Condensate drain pipe**
The units are equipped with a flexible corrugated pipe 800 mm long, pre-assembled with 90° bend fastening. In case of water leakage, the drops are conveyed into the collection tray and directed towards the drain pipe.

Pro ENY-SHP-150 Version

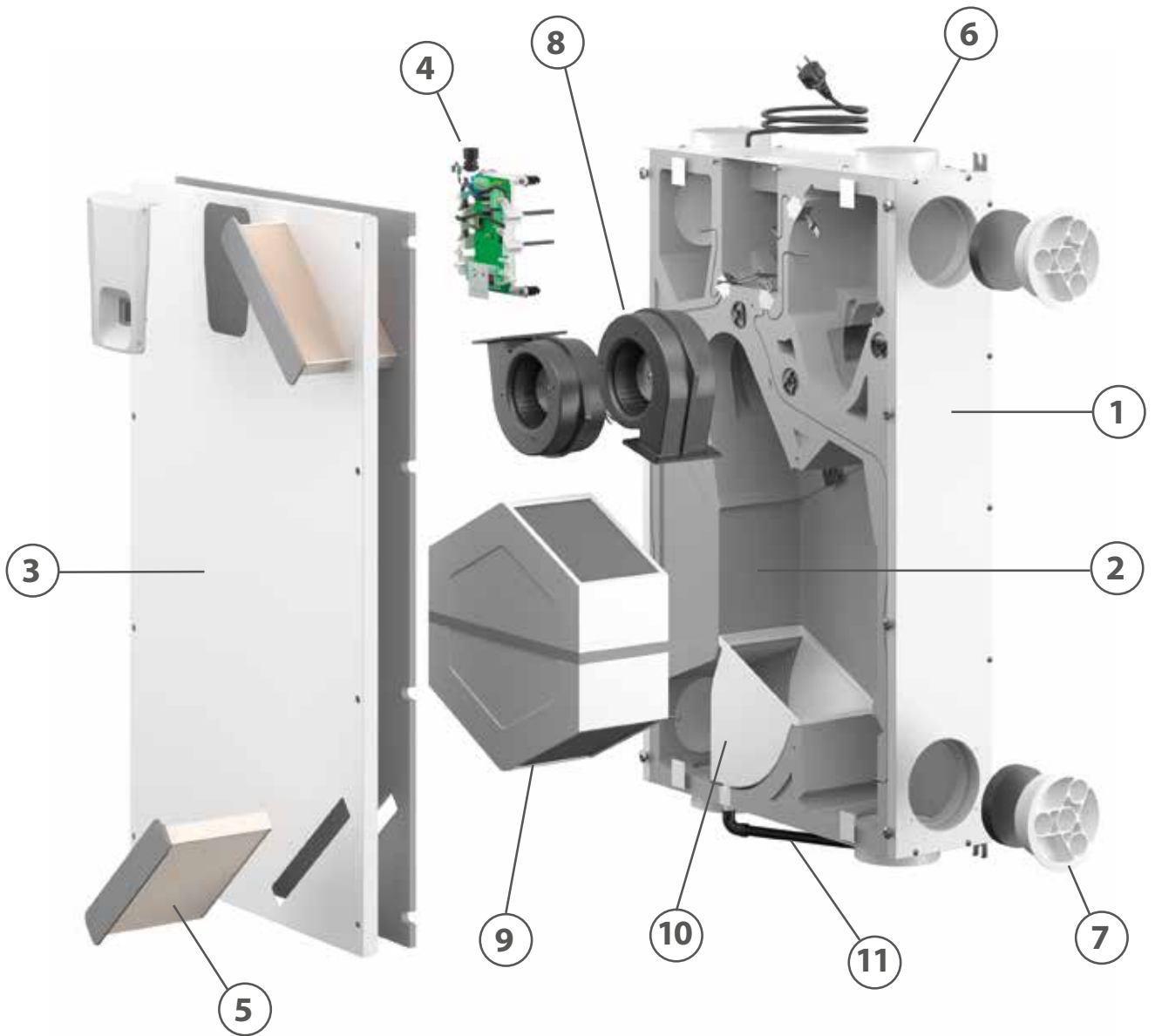

Pro ENY-SHP-170 Version - Construction features of the main components

1 Pro ENY-SHP-170 version external structure

made of hot-dip galvanised steel sheet panels painted in RAL 9003 and satin finish obtained with epoxy paint dried in oven at 180 °C.

2 EPDM fan access closure

3 Polyethylene EPE filter access closure

4 Electric defrosting pre-heater

Electric heater hot filament with reinforced metal lining, controlled by PWM signal (only versions with integrated electric heater).

5 High efficiency filters compliant with standard ISO 16890

The filters have the following features:

- ePM₁ 55% - F7 class for the supply air;
- ePM₁₀ 50% - M5 class for the extracted air.

6 ABS shanks for inlet/outlet flow connection

7/11 Extract air (7) and air supply (11) electric fan

consisting of:

- Permanent single-phase **synchronous EC motor**.
- **High efficiency PA fans** with backward-curved blades.
- **Motor/fan housing**.

8 High efficiency static heat recovery unit

with PET counterflow exchange plates. The reachable efficiency obtainable may be higher than 90% because they ensure counterflow heat transfer between two air flows at different inlet temperatures. The static heat recovery units do not feature moving parts and guarantee high reliability and safe operation.

In order to increase the efficiency of the heat exchanger, the plate surfaces feature special swirlers.

9 By-pass damper with 2 louvers driven by the same motor

10 Main power board

Pro ENY-SHP-170 Version

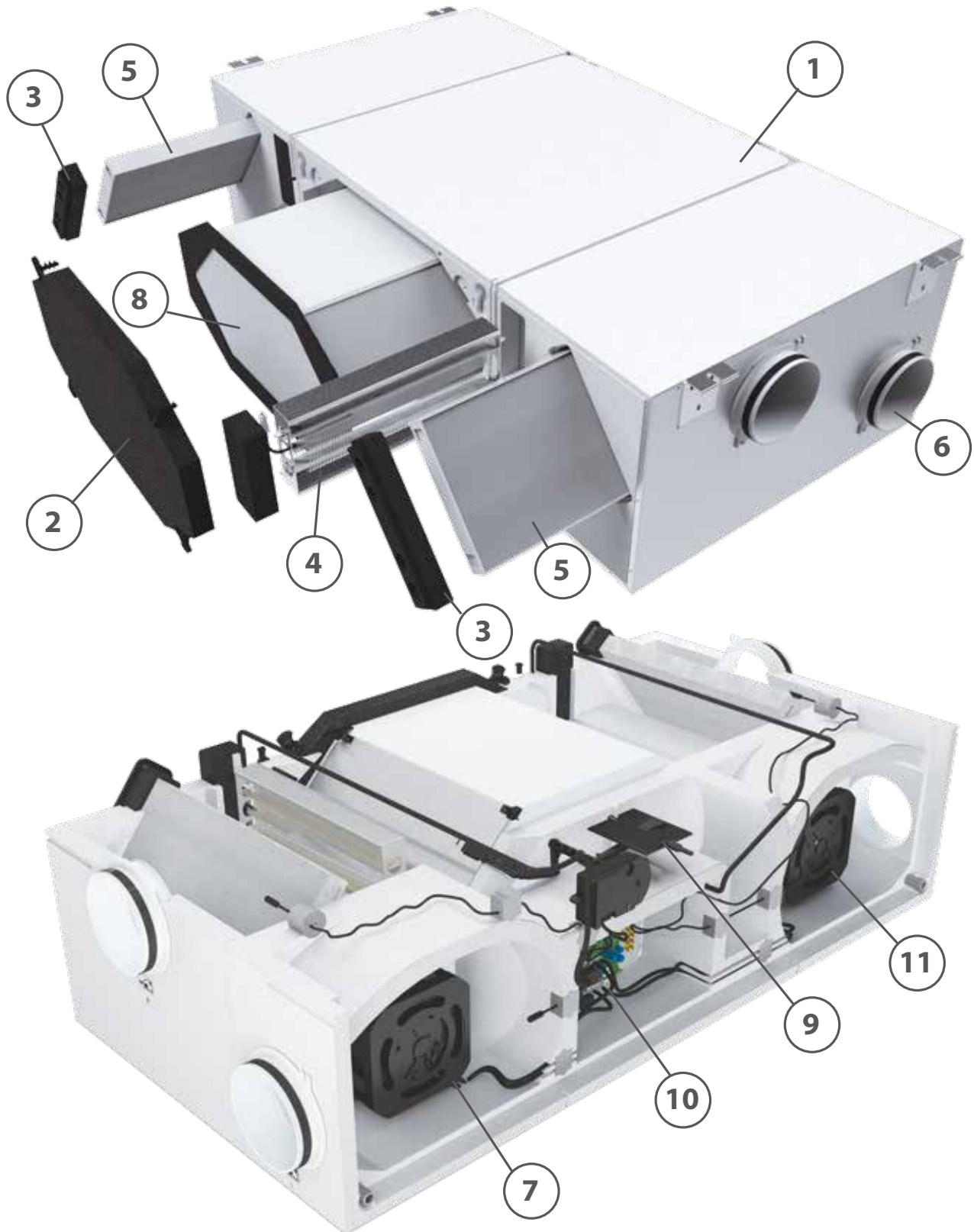

Pro ENY-SHP-270 Version - Construction features of the main components

1 Pro ENY-SHP-270 version external structure

made of hot-dip galvanised steel sheet panels.

2 Internal structure

made of high density Polystyrene.

3 Frontal panel

galvanized, insulated and painted in RAL 9003.

4 Electric defrosting pre-heater

Electric heater hot filament with reinforced metal lining, controlled by PWM signal (only versions with integrated electric heater)

5 High efficiency filters compliant with standard ISO 16890

High efficiency micro-pleated filters, frontal extraction have the following features:

- ePM₁ 55% - F7 class for the supply air;
- ePM₁₀ 50% - M5 class for the extract air.

6 ABS shanks for inlet/outlet flow connection

7 Extract air and air supply electric fan

high efficiency centrifugal fan with EC brushless motor and forward curved blades, steady control of air flow rate.

8 Static recovery unit

Counterflow heat recovery unit with low pressure drops. It prevents any winter heat drops due to the introduction of fresh air, thereby recovering up to 88% of the extract heat.

The static heat recovery units do not feature moving parts and guarantee high reliability and safe operation.

9 By-pass damper with 2 fins activated by stepper motor

10 Condensate collection tray

The condensate collection tray made of ABS is designed for the correct condensate drain in every type of installations, ceiling or wall ones.

11 Main power board

Pro ENY-SHP-270 Version

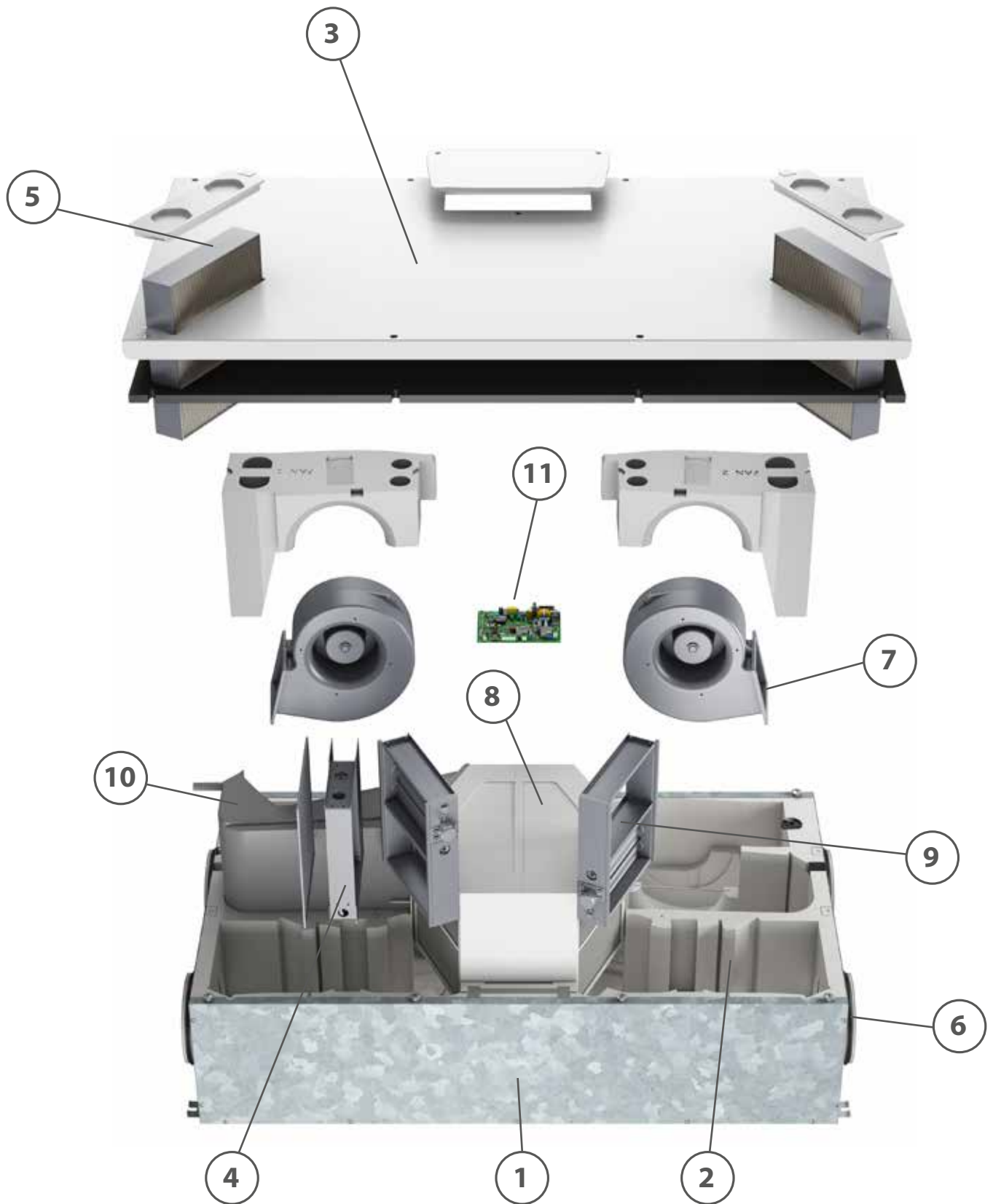

ENY-SHP-150 - Ceiling or Vertical Installation

The standard configuration of the unit provides that the air distribution connections are fitted on the short sides of the unit, with the extract air fan fitted on the short side nearest to the control panel.

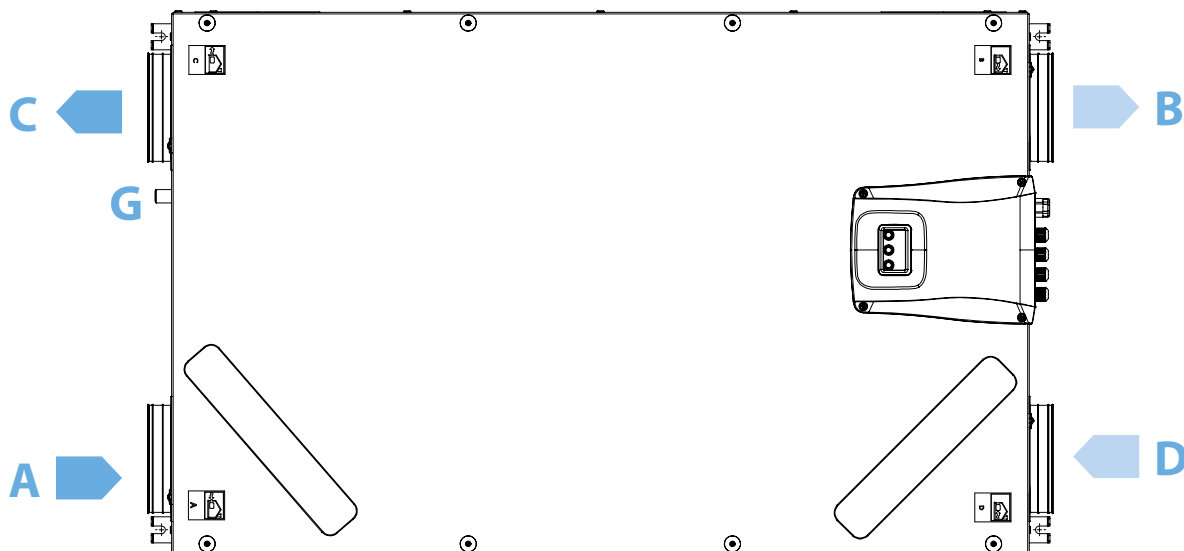

VIEW FROM ABOVE

If necessary, it is possible to turn of 90° the position of one or more air connections to drive them on the long side near the unit.

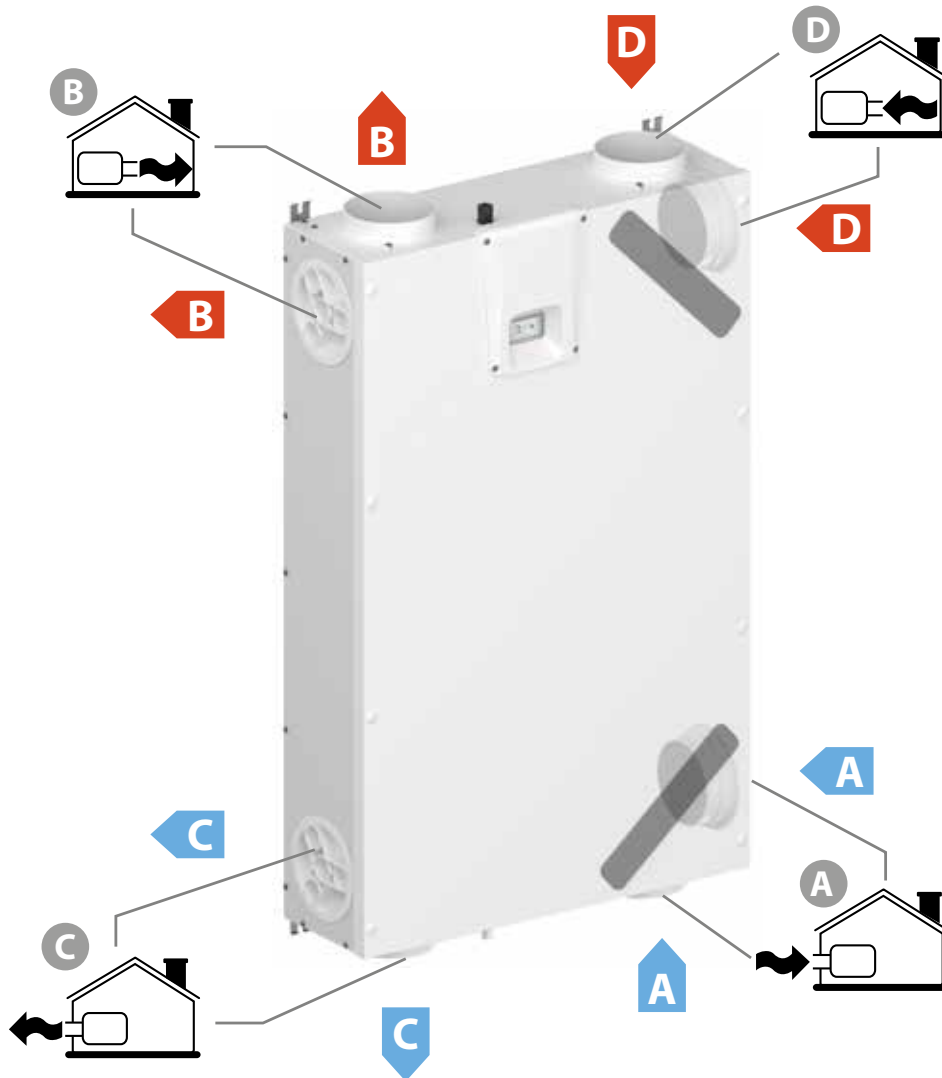

- A = Fresh air
- B = Supply air
- C = Exhaust air
- D = Extract air
- G = Condensate drain

ENY-SHP-170 - Ceiling Version

The standard units are configured with the supply fan on the front left side and the ePM₁ 55% - F7 filter to the right, whereas the extracted air flow connection is located on the right side with the ePM₁₀ 50% - M5 filter to the left. If necessary, it is possible to invert the flows by inverting the position of the filters, the position of the condensate drain, the position of the humidity probe and paying attention to the proper connection of the ducts to the machine; below is the standard configuration and the inverted flow configuration.

Default right side configuration

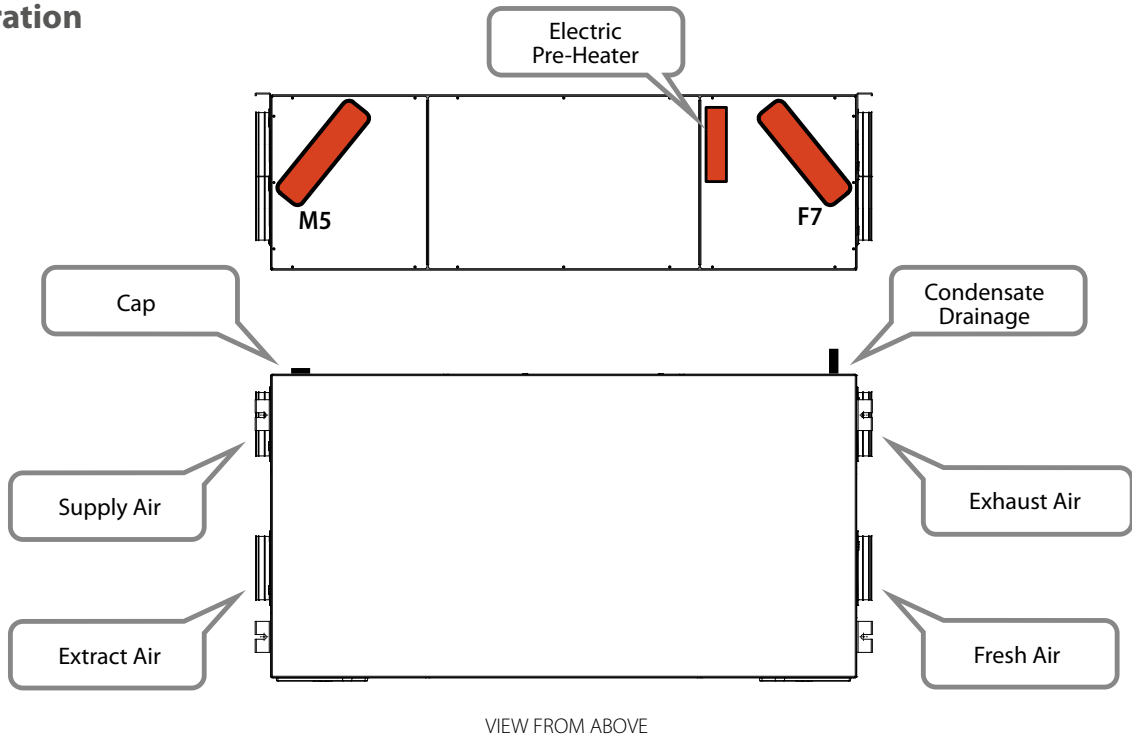

Optional left side configuration

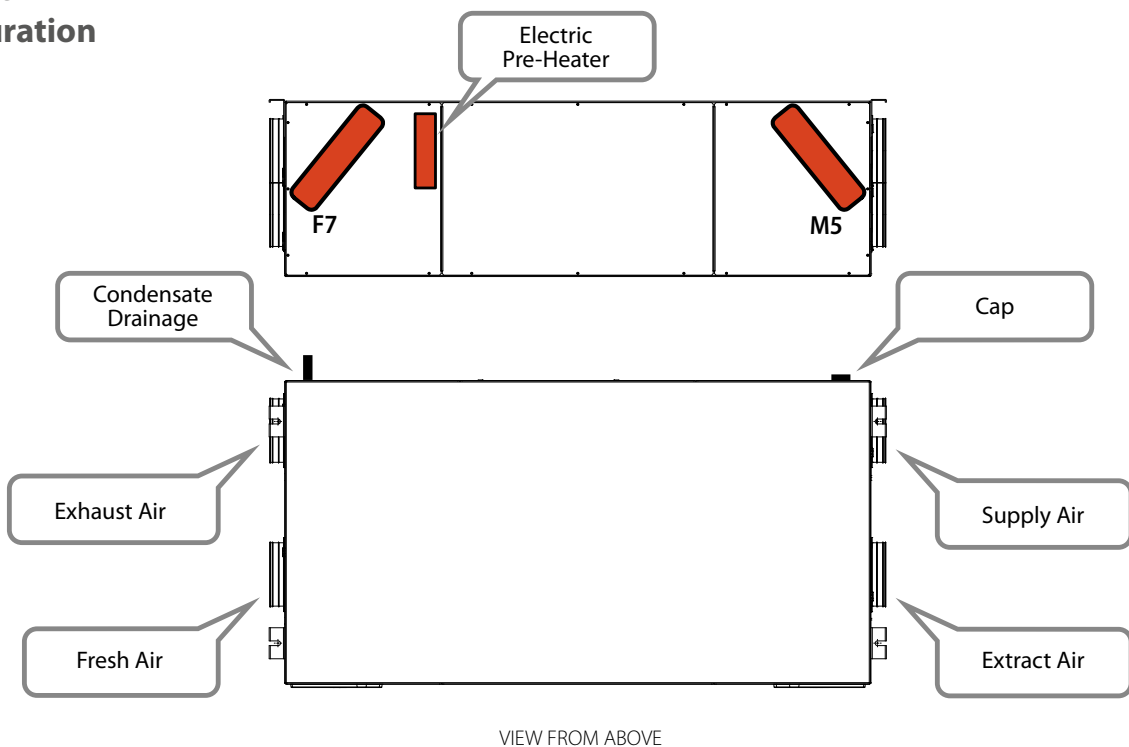

ENY-SHP-170 - Wall Version

By default, the units are configured in order to position the supply fan at the top, with the ePM₁ 55% - F7 filter at the bottom, while the extraction flow connection is located at the bottom with the ePM₁₀ 50% - M5 filter at the top. The flows can be inverted if necessary; below there is the standard configuration and the inverted flow configuration.

Standard initial configuration

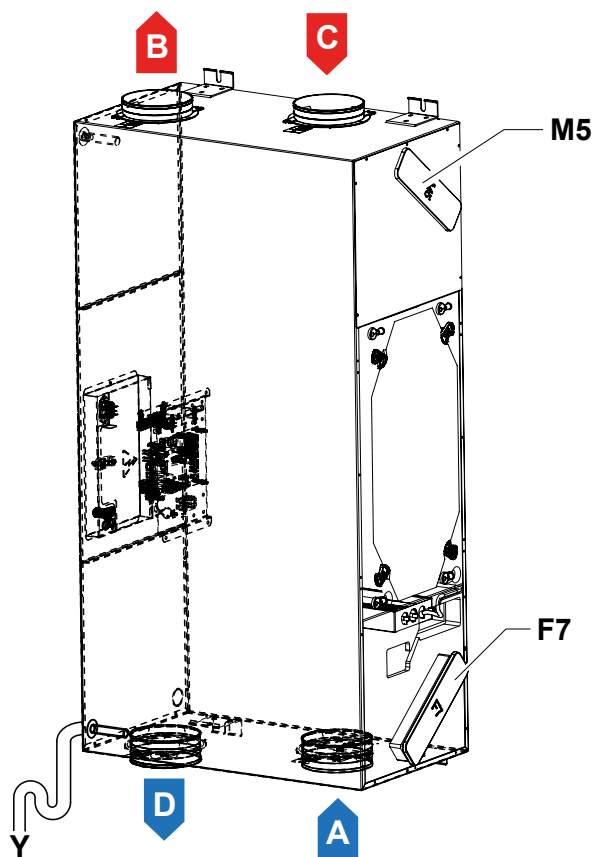

Final inverted configuration

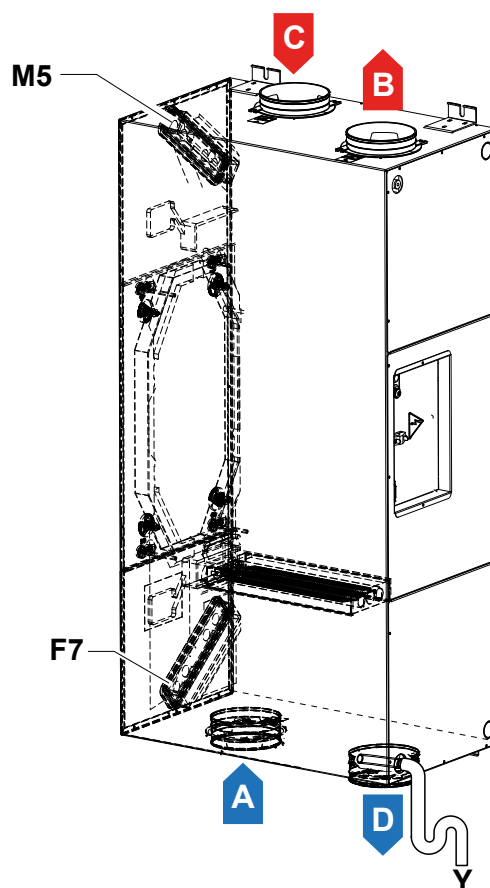

- A = Fresh air
- B = Supply air
- C = Exhaust air
- D = Extract air

ENY-SHP-270 - Ceiling Version

The standard units are configured with the supply fan on the front left side and the ePM₁ 55% - F7 filter to the right, whereas the extracted air flow connection is located on the right side with the ePM₁₀ 50% - M5 filter to the left.

ATTENTION: It is not possible to invert the unit on site but it is possible to order the unit into the right configuration. Pay attention to the correct duct connection to the unit; as follows the standard configuration and the configuration with inverted flow rates are shown.

Horizontal left unit installation

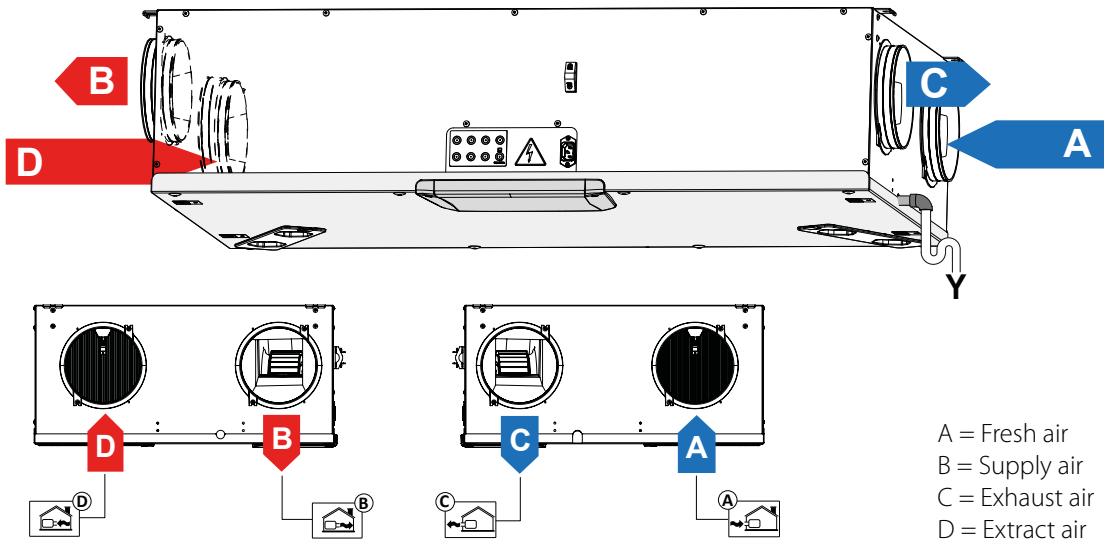

Horizontal right unit installation

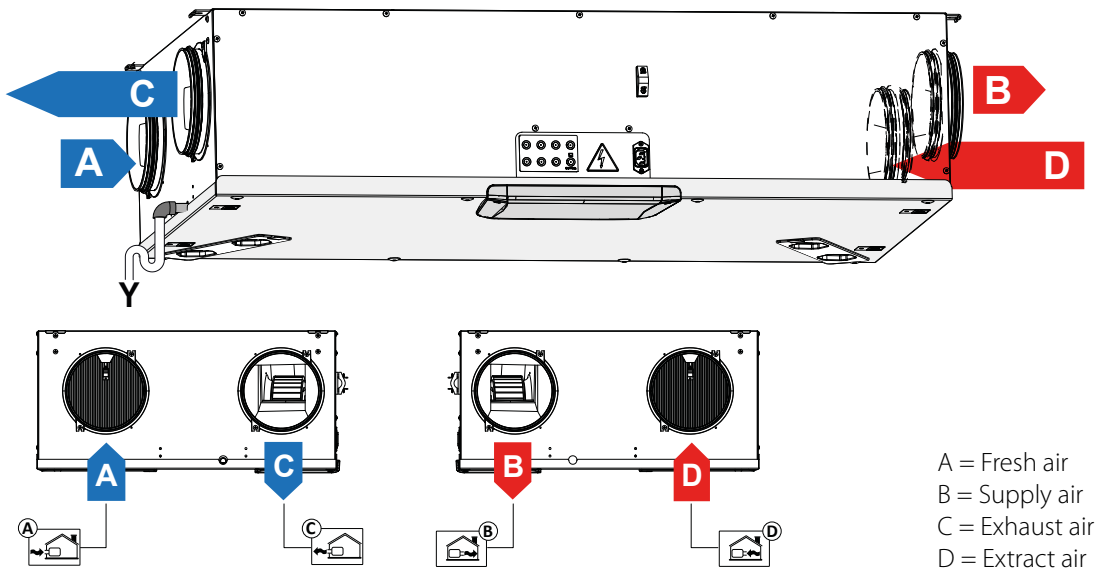

ENY-SHP-270 - Wall Version

By default, the units are configured in order to position the supply fan at the top, with the ePM₁ 55% - F7 filter at the bottom, while the extraction flow connection is located at the bottom with the ePM₁₀ 50% - M5 filter at the top.

ATTENTION: It is not possible to invert the unit on site but it is possible to order the unit into the right configuration. Pay attention to the correct duct connection to the unit; as follows the standard configuration and the configuration with inverted flow rates are shown.

Vertical left unit installation

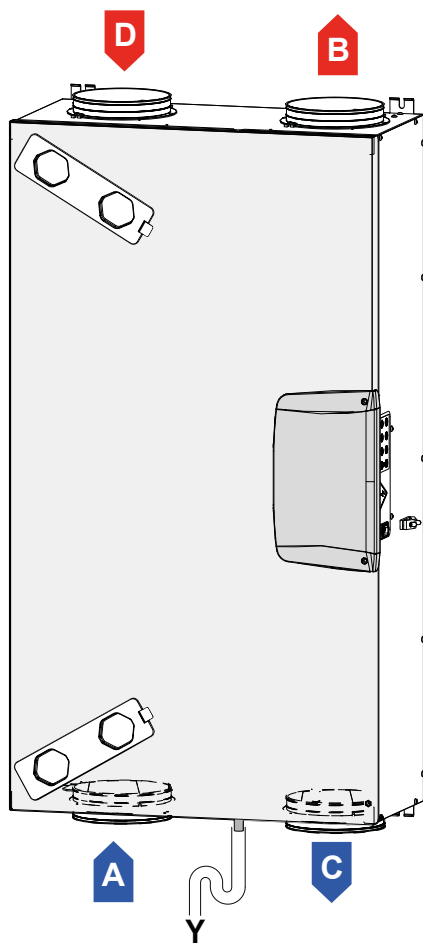

Vertical right unit installation

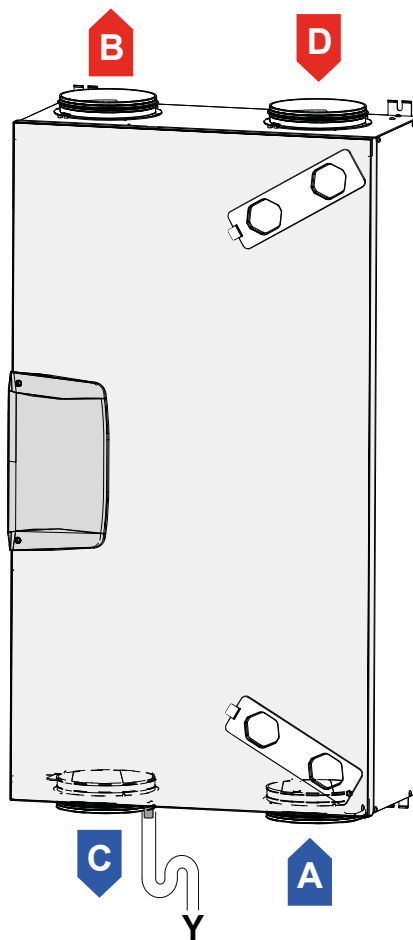

- A = Fresh air
- B = Supply air
- C = Exhaust air
- D = Extract air

ENY-SHP-150 DIAGRAM

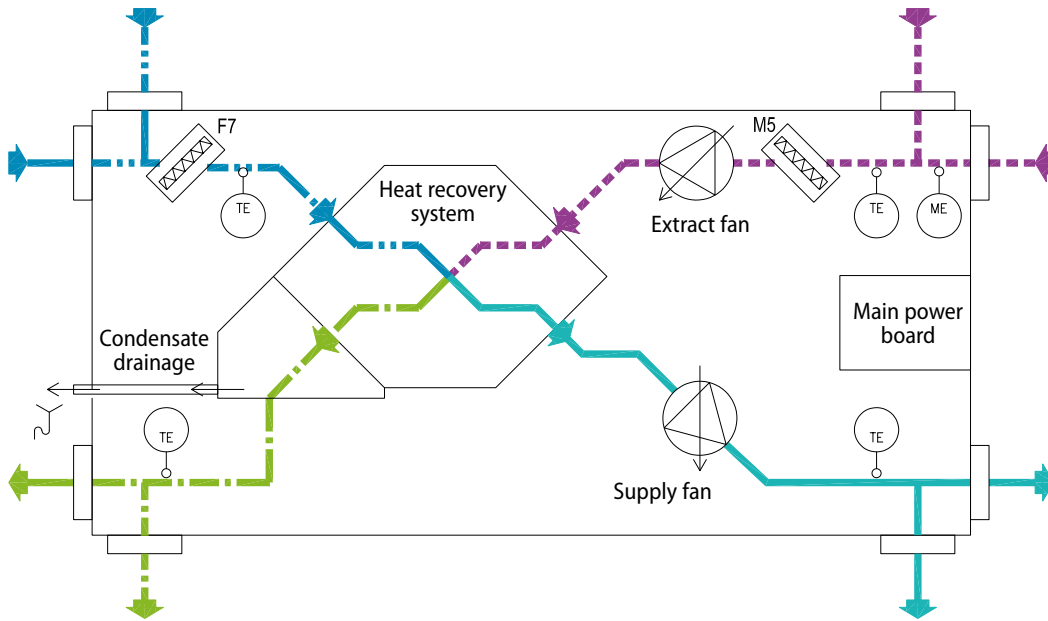

ENY-SHP-170 DIAGRAM

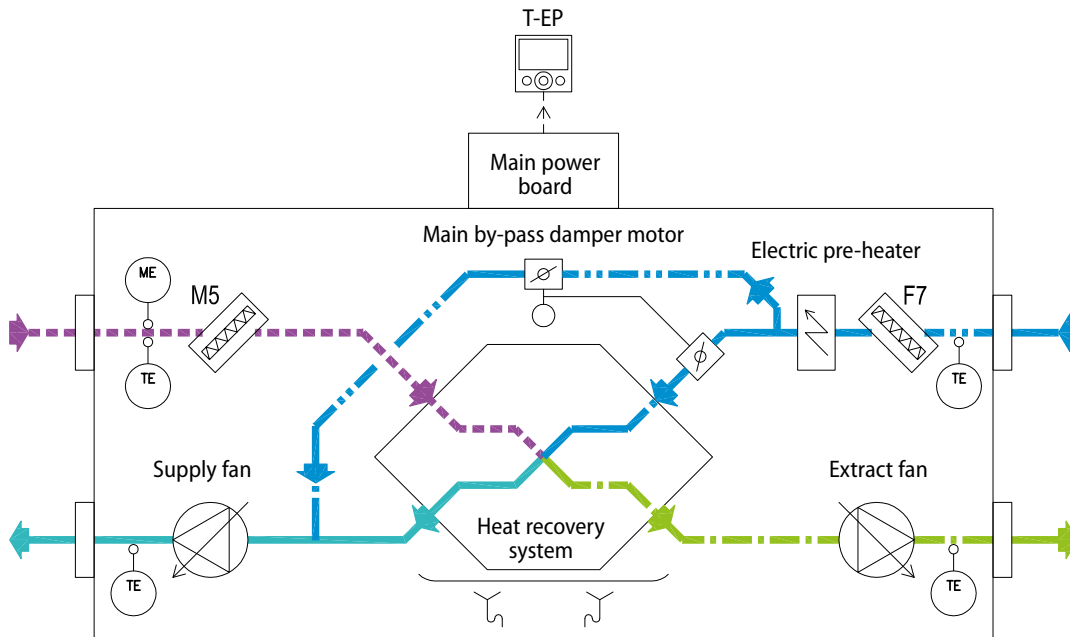

LEGEND

	fresh air		remote control only for vertical unit
	supply air		electric pre-heater optional only required for cold climates
	extract air		temperature sensor
	exhaust air		humidity sensor central demand control
	micro pleat filter		condensate drainage

ENY-SHP-270 DIAGRAM

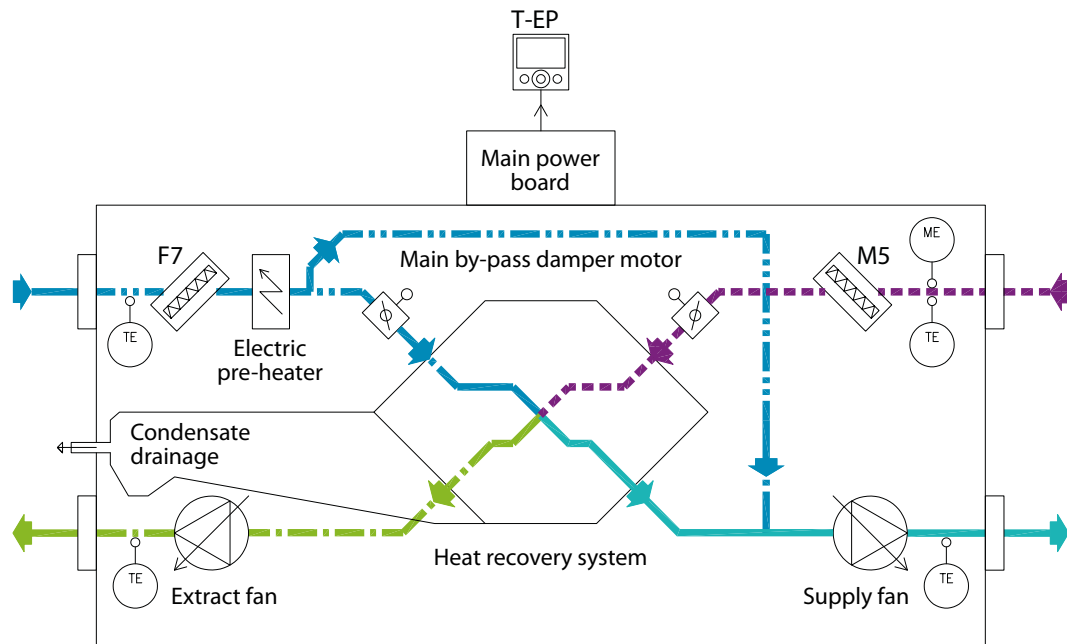

LEGEND			
	fresh air		remote control only for vertical unit
	supply air		electric pre-heater optional only required for cold climates
	extract air		temperature sensor
	exhaust air		humidity sensor central demand control
	micro pleat filter		condensate drainage

Thermal performance

The thermal performance was measured in compliance with Standard EN 13141-7, recommended by the European Commission documents enclosed in EU Regulation 1253-14.

The conditions relating to the charts are the following:

- fresh air temperature = 7 °C
- indoor air temperature = 20 °C
- internal relative humidity = 45%

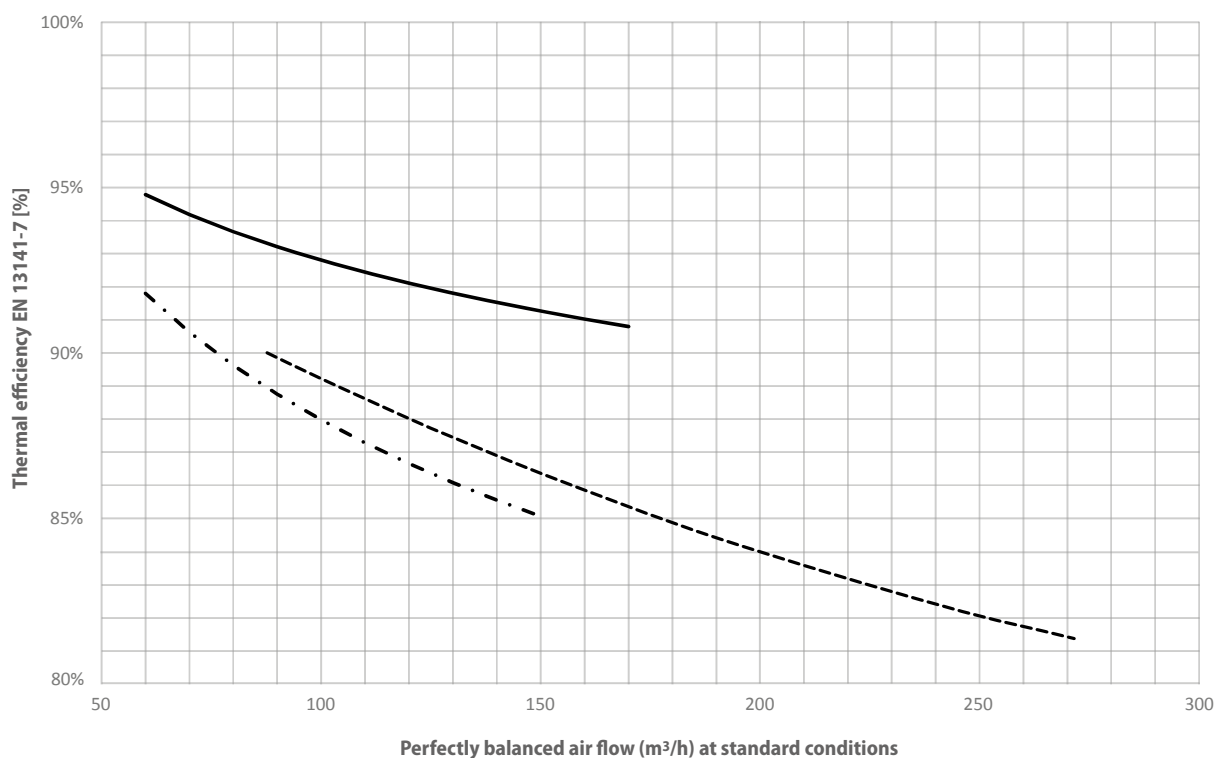

- · - · - ENY-SHP-150
- ENY-SHP-170
- - - ENY-SHP-270

ENY-SHP-150

All mechanical efficiency curves are measured in standard air conditions (1 atm, 20 °C).

- Air flow: min. 60 m³/h, max. 150 m³/h.
- Curves with nominal flow rate 60, 83, 105, 128, 150 m³/h.

Supply air

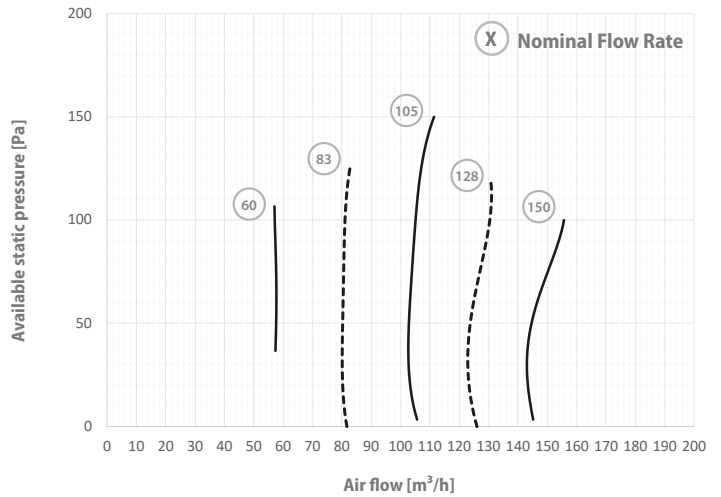

Extract air

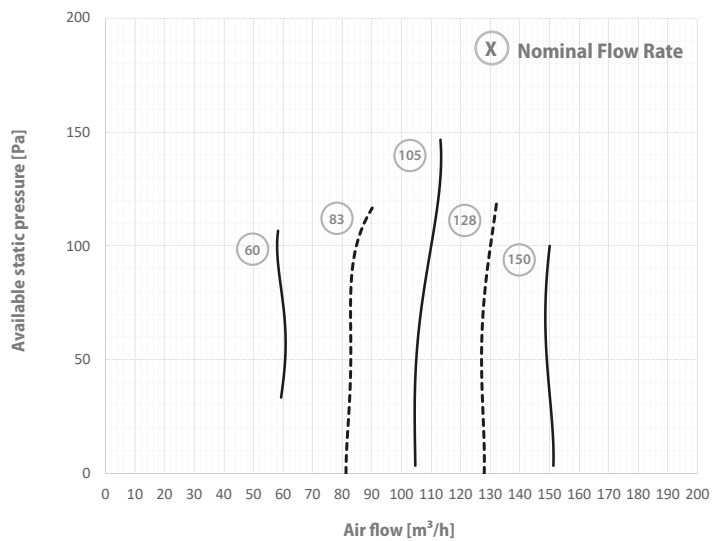

Power absorbed

The curves apply in the event of balanced flow rates.

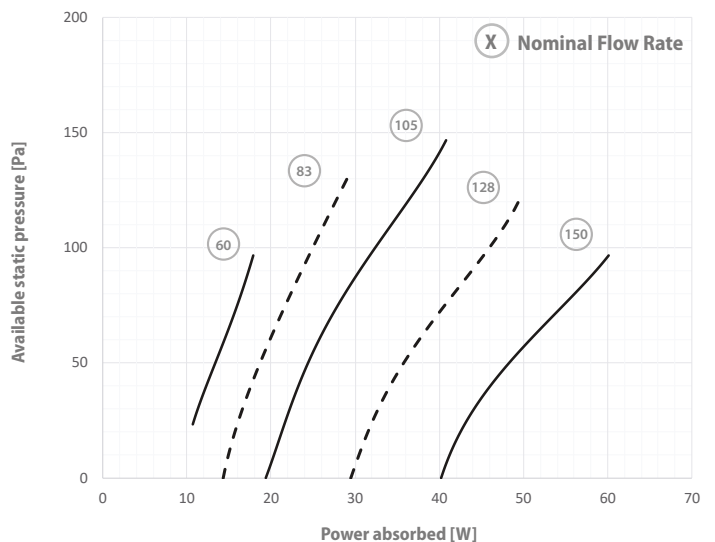

The minimum voltage indicated only refers to a minimum value that can be configured during the nominal flow rate calibration procedure. In fact, during normal operation the motors can operate at lower voltages.

ENY-SHP-170

All mechanical efficiency curves are measured in standard air conditions (1 atm, 20 °C).

- Nominal flow rate range $V_{max} = 8,9 V$; $V_{min} = 3,0 V$.
- Maximum current input $I_{max} = 0,6 A$ a 10 V.

Supply air

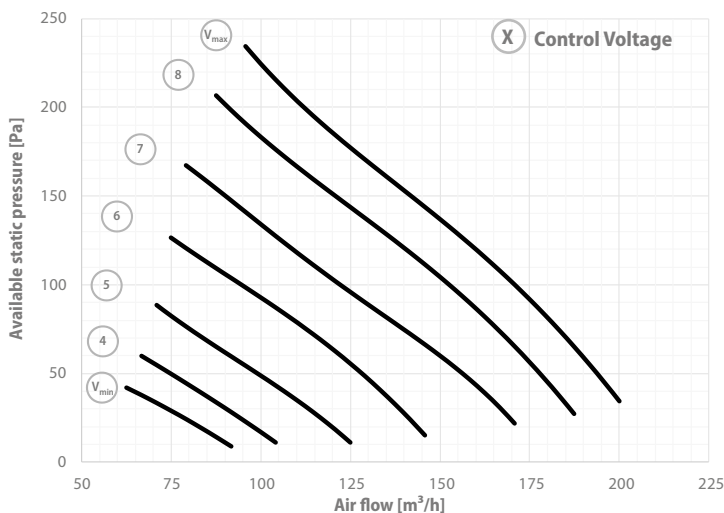

Extract air

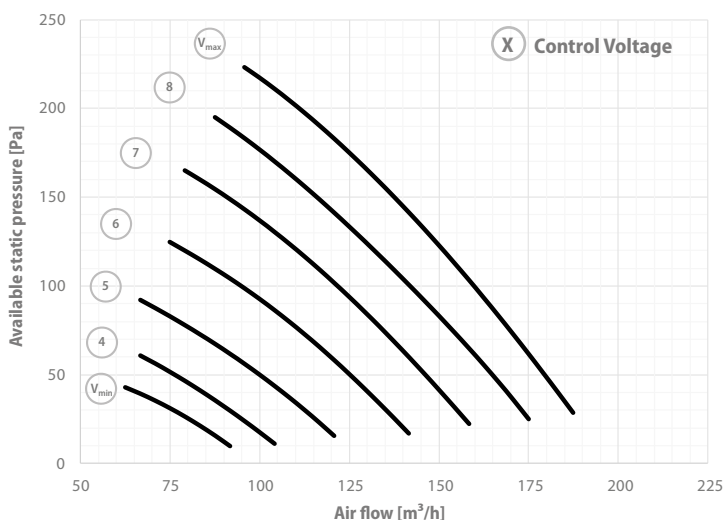

Specific fan power - SFP

SFP includes the consumption of the fans and controls. The curves apply in the event of balanced flow rates.

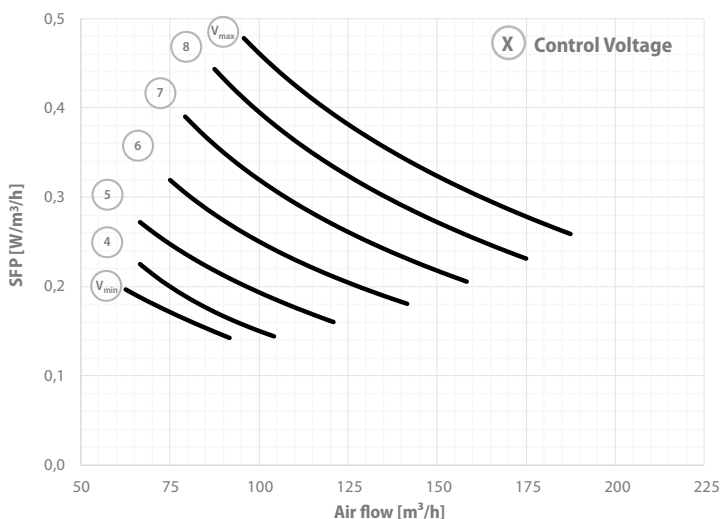

The minimum voltage indicated only refers to a minimum value that can be configured during the nominal flow rate calibration procedure. In fact, during normal operation the motors can operate at lower voltages.

ENY-SHP-270

All mechanical efficiency curves are measured in standard air conditions (1 atm, 20 °C).

- Air flow: min. 88 m³/h, max. 270 m³/h.
- Curves with nominal flow rate 88, 100, 150, 190, 270 m³/h.

Supply air

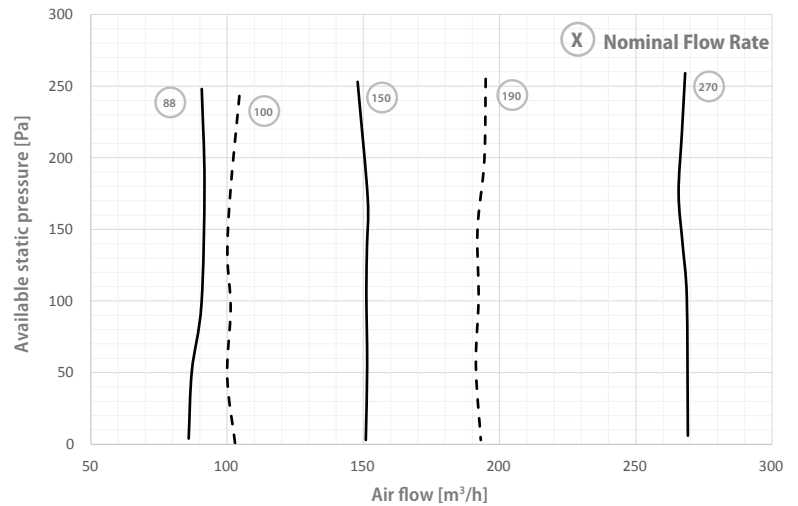

Extract air

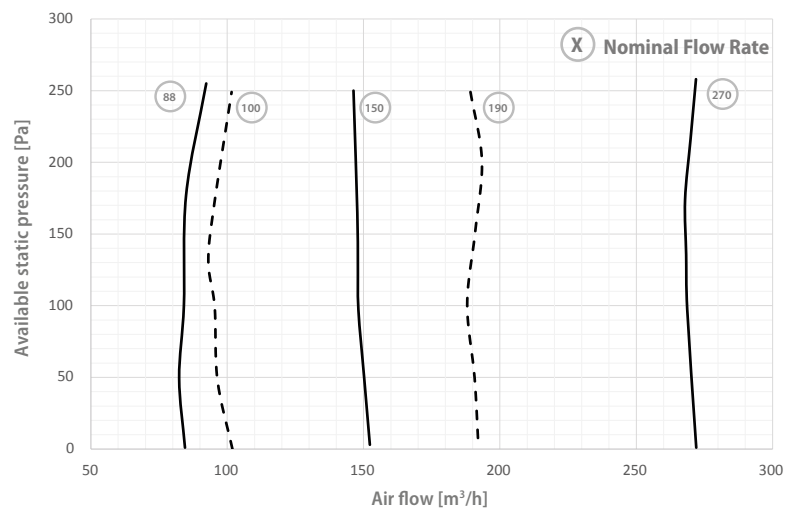

Power absorbed

The curves apply in the event of balanced flow rates.

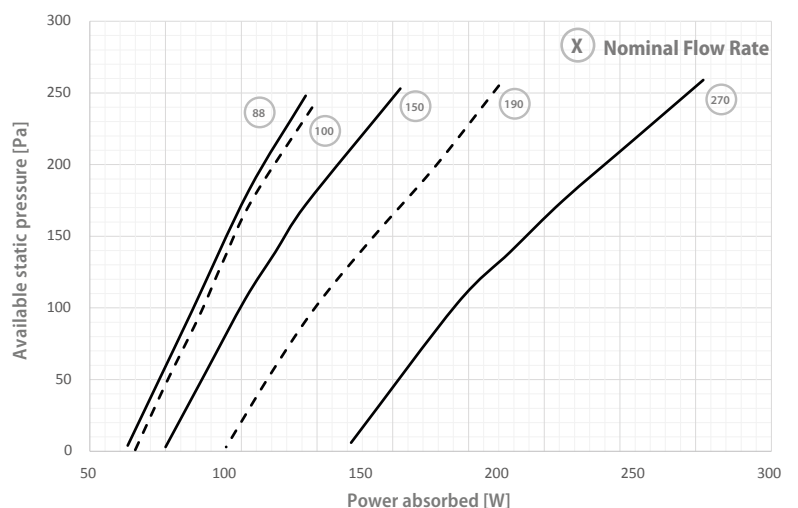

The minimum voltage indicated only refers to a minimum value that can be configured during the nominal flow rate calibration procedure. In fact, during normal operation the motors can operate at lower voltages.

Energy Smart units are designed for controlled air exchange in residential ambiances and minimise heat dissipation due to ventilation.

As a result, the units must be sized according to the project air exchange flow rate (nominal flow rate Q_{SN}), based on the calculation rule applicable in the country where the unit is installed.

The calculation rule usually applied in Europe is Standard **DIN 1946-6**, therefore the nominal flow rates recommended are specified according to the area of the building heated directly or indirectly (table 5 of the standard). At the same time, the intake flow rate should not be less than the general extraction flow rate required (table 7 of the standard), while the **air exchange per person should be greater than or equal to 30 m³/h or, in the event of a particularly high density, greater than or equal to 20 m³/h.**

However, it is possible to use alternative calculation rules, in accordance with the national legislation in force or with the designer's policy.

After calculating Q_{SN} , it is the responsibility of the designer to assess the need of balancing the extraction flow (Q_{EN} = nominal extraction flow rate)*, as well as the value of the project static pressure, which must be indicated for each flow in order to counteract the pressure drops of the air ducts and distribution components (Δp_{SN} , Δp_{EN}).

Once the nominal flow rate/static pressure values have been defined, it is possible to use the pressure-flow rate diagrams to identify the most suitable model.

The model must be selected in order to enable the “Booster”/“Party” modes, which increase the nominal flow rate by 30%, resulting in an increase of the required static pressure.

Selection procedure:

1. The **maximum supply** and **maximum extraction flow rates** are defined as follows:

- a. $Q_{SN_max} = 1.3 Q_{SN}$
- b. $Q_{EN_max} = 1.3 Q_{EN}$

2. Quick selection procedure, through “fast selection table and diagrams”

Identify the model whose declared maximum flow rate is just above the maximum value between Q_{SN_max} and Q_{EN_max} .

3. Check that the following maximum supply and extraction points are within the operating ranges of the fans of the selected unit:

- a. $(Q_{SN_max}; \Delta p_{SN_max})$, where $\Delta p_{SN_max} = 1.7 \Delta p_{SN}$
- b. $(Q_{EN_max}; \Delta p_{EN_max})$, where $\Delta p_{EN_max} = 1.7 \Delta p_{EN}$

4. In the event of a negative result, choose the larger model.

* An imbalance of $\pm 10\%$ between the supply flow and the extraction flow is usually accepted.

Example of model selection

Let's suppose a designer is interested in a vertical ENY-SP unit to be installed in a newly built flat.

Let's suppose that the designer calculates the following data, with the resulting identification of the maximum flows:

Supply flow	Extraction flow
$Q_{SN} = 160 \text{ m}^3/\text{h}$	$Q_{EN} = 140 \text{ m}^3/\text{h}$
$\Delta p_{SN} = 90 \text{ Pa}$	$\Delta p_{EN} = 80 \text{ Pa}$
$Q_{SN_MAX} = 1.3 (160) \approx 210 \text{ m}^3/\text{h}$	$Q_{EN_MAX} = 1.3 (140) \approx 180 \text{ m}^3/\text{h}$
Quick selection flow rate $Q_{QS} = \max(210; 180) = 210 \text{ m}^3/\text{h}$	

		ENY-SP-180	ENY-SP-280	ENY-SP-370	ENY-SP-460	ENY-SP-600
Q_{max}	[m ³ /h]	180	280	370	460	600
Q_{rif}	[m ³ /h]	130	200	260	320	420

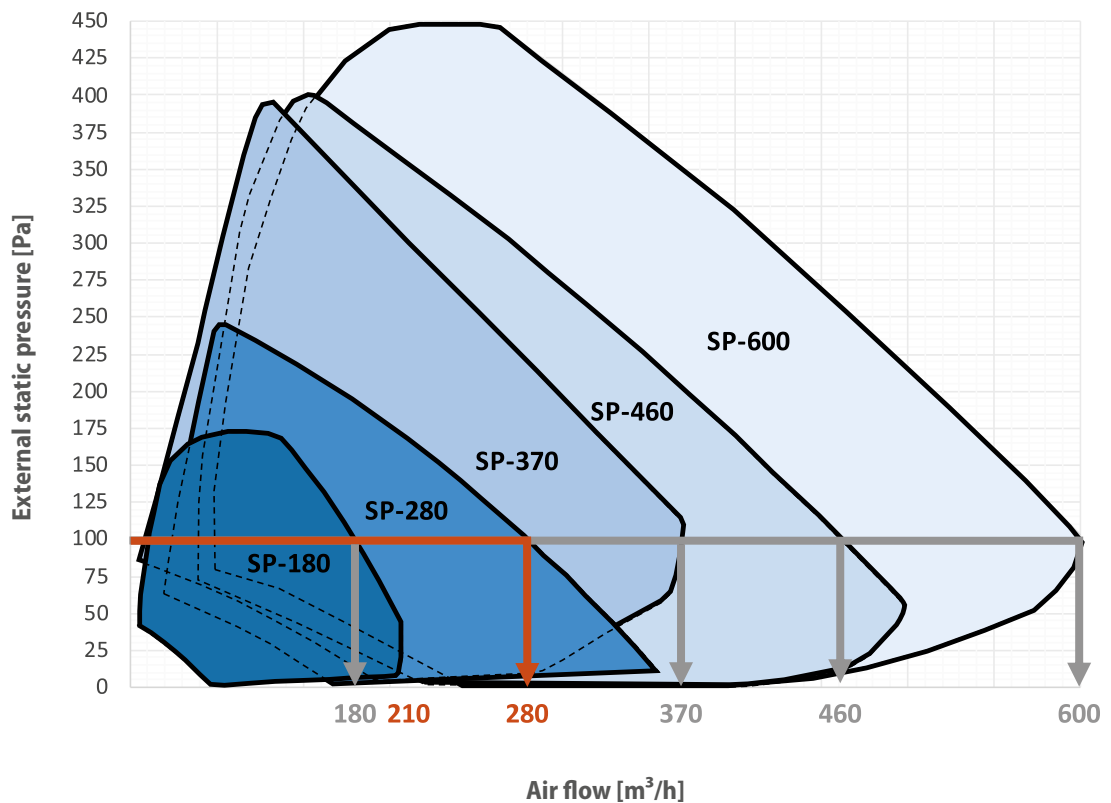

Model ENY-SP-280
is selected as the most suitable unit.

The following checks must in any case be performed in order to calculate the maximum power consumption of the unit:

Operating supply points control

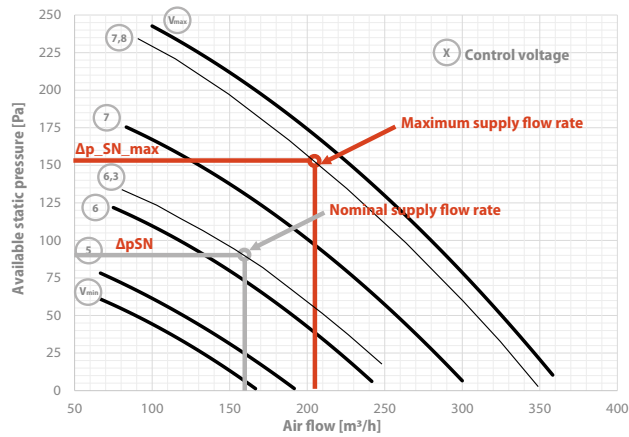

Operating extraction points control

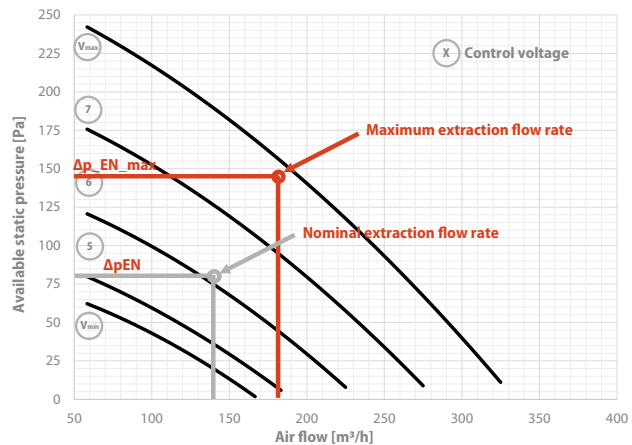

The maximum supply and extraction capacity can be processed by the selected unit ENY-SP-280. In this case, the supply flow may be considered the main one because it is the one that involves the highest consumption between the two flows.

Power consumption

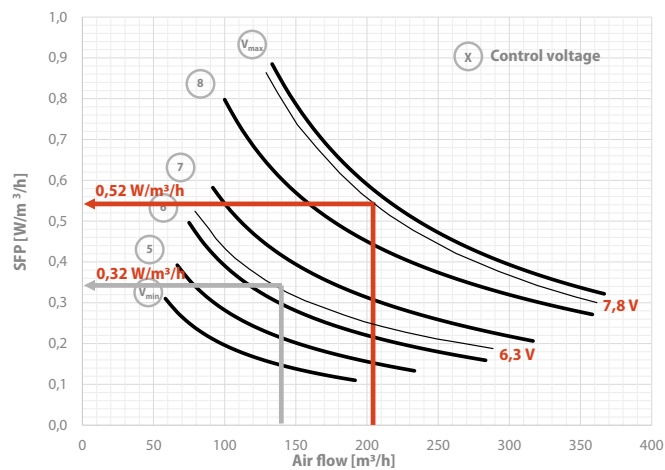

Hypothesis:

Unit without electric heater and set in the conservative case of flows balanced to the flow rate and available static pressure of the main flow.

$$P_{\max} = 110 \text{ W}$$

$$P_{\text{nom}} = 45 \text{ W}$$

LEGEND of the selection procedure

Q_{SN}	Nominal supply flow rate
Δp_{SN}	Nominal supply external static pressure
Q_{SN_max}	Maximum supply flow rate
Δp_{SN_max}	Maximum supply external static pressure
P_{max}	Maximum electric power generated by the fans and controls in maximum flow and balanced flow conditions

Q_{EN}	Nominal extraction flow rate
Δp_{EN}	Nominal extraction external static pressure
Q_{SN_max}	Maximum extraction flow rate
Δp_{EN_max}	Maximum extraction external static pressure
P_{nom}	Electric power generated by the fans and controls in nominal flow and balanced flow conditions

All the ENERGY SMART vertical units and the ENY-SHP-170 and ENY-SHP-270 horizontal size are equipped with a heat recovery by-pass function, when it is beneficial to use the fresh air free-cooling (or free-heating) function.

The following setpoint temperatures must be set:

Internal heating system setpoint

- t_{heating} , usually set at 20 °C

Internal cooling system setpoint

- t_{cooling} , usually set at 26 °C

The temperatures entered must be determined by the installer in accordance with the Heating/Cooling system provided in the unit installation room.

Other temperatures are also defined:

- T_i , i.e. the internal temperature
- T_{AE} , i.e. the external temperature

The following operating modes of the bypass damper (free heating/free cooling) are available:

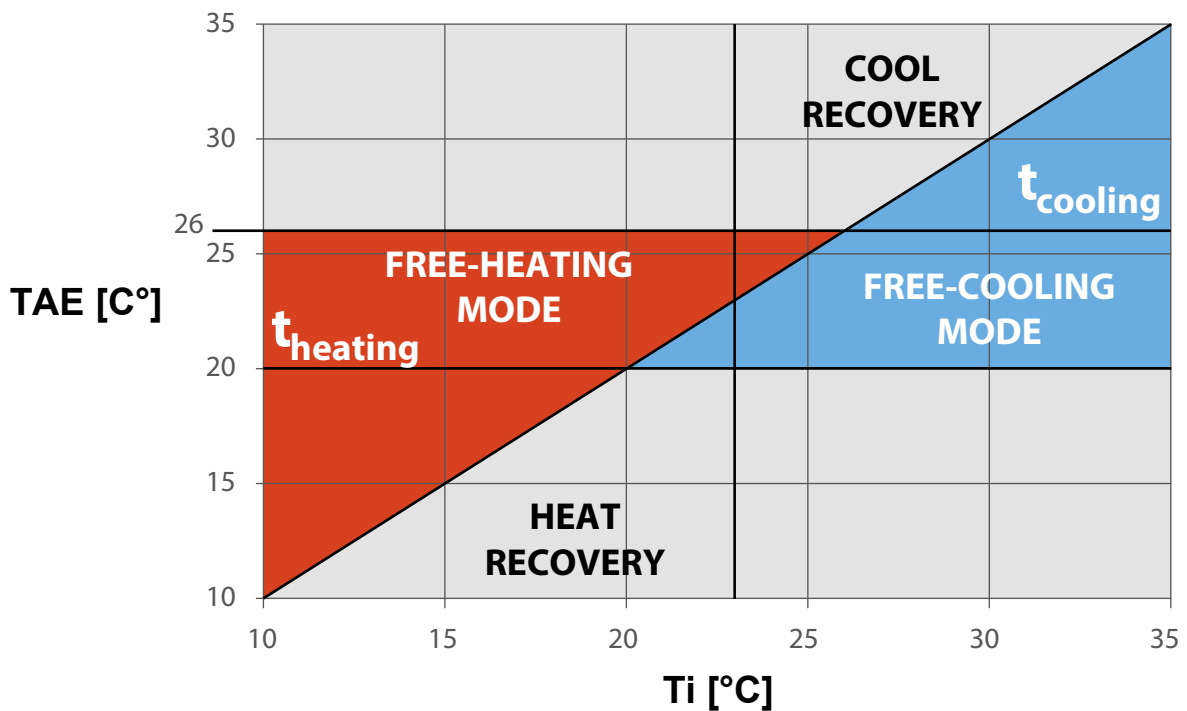

If a geothermal water resource is available, a Dip Switch configuration can be used to control an on-off valve of a geothermal water coil, supplied by a third party and installed in a fresh air pre-treatment position. The geothermal water coil can be used in summer for pre-cooling fresh air, thus enhancing the standard free-cooling mode.

In fact, thanks to the pre-treatment, the cooled fresh air can be used in free-cooling mode even in warmer outdoor conditions than those normally used to operate by-pass dampers. In winter, the geothermal coil can be used as a hydronic antifreeze system, which ensures considerable energy savings compared to electrical systems.

Instead for the size ENY-SHP-150 the free-cooling is a manual function, that can be activated only with the optional accessory T-EP. For this size this function works only for the activation of supply air flow and for the deactivation of the extract air flow. In the free-cooling mode it is advisable to open a roof window in a living room.

T-EP control

The Energy Smart vertical units and the ENY-SHP-170 and ENY-SHP-270 horizontal sizes are equipped as standard with a T-EP control panel. For the size ENY-SHP-150 such an interface is an accessory instead. The use of the interface is very intuitive and thanks to the icons on the screen, the two keys and the touchpad, it is possible to display and change the operating status of the unit, display the values read by the temperature sensors and humidity sensor (if any), and display any alarm. The use of the interface is simplified by the presence of two sub-menus:



- **User Settings Menu** where the user can select the operating mode and set the clock
- **Technical Settings Menu** where the installer can calibrate the flow rates, change the unit operating parameters and monitor the operating status.

The **user settings menu** is used to select the following unit operating modes:

- **Manual Mode:** customised selection of desired air flow rate in manual mode:
 - 100% - Nominal ventilation (standard)
 - 70% - Reduced ventilation (nighttime)
 - 45% - humidity control for high humidity rate environments
 - 25% - humidity control for low humidity rate environments

When this function is active on the main screen, the corresponding icon



- **Party Mode:** timed function, active for 3 hours after activation, in which the nominal speed is increased by 30%. When this function is active on the main screen, the icon



- **Holiday Mode:** anti-mould function with the fans at minimum speed. When this function is active on the main screen, the icon



- **Automatic Mode:** speed controlled by means of an automatic control cycle relating to ambient instantaneous humidity and CO₂ variations. This mode is only available for the Pro version or for units equipped with an air quality sensor (humidity or CO₂). When this function is active on the main screen, the icon **AUTO** will also be active.

The user menu is also used to set the clock and perform weekly programming.

The **technical settings menu** is used to:

- Confirm or edit the operating parameters.
- Monitor the operating conditions.
- Set the nominal calibration speed of the fans.
- Enter and select the weekly program available to the user.

The Energy Smart Units not equipped with antifreeze electric heater, come with an **antifreeze function**, which, with a preventive logic, automatically sets the supply fan at minimum for 10 minutes every hour when the fresh air drops below - 5 °C. Also, if the temperature drops below -10° C, the unit stops automatically and a **"FROST"** alarm appears on the display. When the alarm is active, the unit switches off and restarts automatically when the critical climatic condition disappears. The "Frost" alert remains until the unit is switched off and back on. For units with electric heater, both integrated and installed as an external accessory, the activation of the electric heater is signalled on the T-EP with the activation of the icon

For more information about the electric heater intervention logic, please refer to the dedicated chapters (p. 67-68).

Energy Smart units are equipped with a **visual warning signal when the filter needs replacing**. The signal is displayed via an icon on the main screen of the T-EP panel.

When the filters need replacing, the icon  will turn on. Once the filters have been replaced, it is recommended to follow the warning icon removal procedure in order to reset the next countdown.

The T-EP control can be used to inhibit one or several functions among Party, Holiday, Manual, AUTO, machine shutdown ("OFF"), clock, weekly programming. When the **lock function** is active, the icon  will appear on the auxiliary function lock screen and the locked functions will be disabled on the user screens.

Through 3 different dry contacts, the electronic board is also used to control:

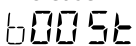
- the **remote ON/OFF function** (contact C1-C1 closed = unit OFF)
- the **"Booster"** mode (contact C2-C2 closed="Booster" active) that, as with the "Party mode", determines a 30% increase in fan speed with respect to the nominal speed for the next 3 hours. If the function is active, the corresponding icon  on the T-EP will also be active
- the "fireplace" function or the "boiler" function (contact C3-C3). If the unit is interfaced with a negative pressure ambient pressure switch and is set in the DIP-SWITCH configuration recommended in presence of a natural draught chimney, the unit is turned off automatically when the fireplace is lit. This occurs in order to prevent the ambient pressure induced by the action of the dual flow ventilation unit from counteracting the natural draught of the fireplace and releasing smoke into the room. If the unit is interfaced with a remote switch and is set in the DIPSWITCH configuration recommended in presence of an atmospheric boiler, the unit is forced into a strong imbalance supply mode in order to facilitate ignition of the boiler. The mode remains active as long as the switch stays in the activation position.

Refer to the Installation Manual for more information.

Interfacing with Modbus protocol

The machines are equipped with a Modbus communication port that enables the units to be included in a supervisory network, which can be consulted from an operating control unit for their remote tracking, control and monitoring. Thanks to the interfacing with the Modbus protocol, finally, the Energy Smart network can be integrated into the more complex context of a global Building Management System. The Technical Manual for interfacing Energy Smart units with Modbus protocol is available on request.

ENY-SHP-150 Control panel

The **Energy Smart ENY-SHP-150** unit is equipped with a built-in display of the control fitted on the unit. The control is easy to use and lets the reset of filter change timer and having access to the technical menu of the following functions:

- To do the automatic fan calibration during the installation.
- To set the filter change time during the installation.
- To set the automatic operating mode with the use of the built-in humidity probe.
- To activate the external modulating electric heater or relay for the ON/OFF valves with the antifreeze pre-heating function.
- To set the dry contact terminals and the digital signal during the installation.
- To visualize the operating parameters.
- To visualize the alarm and filter change notifications.
- To activate further ventilation modes with the use of the T-EP Accessory.



Generally, Energy Smart units operate at a constant flow rate, which can be set at a percentage of the nominal value configured during installation.

A variable flow mode (AUTO) is also available, according to a control based on the ambient air quality index reading (humidity or CO₂). This way, it is the minimum unit flow rate to be required to obtain the necessary air quality, thus improving internal comfort and energy consumption.

The central air quality sensors can be placed directly in the room or in the air extraction ducts.

Since in any case the unit electronics are designed to control only one central sensor, the control strategy is called "Centralised Control".

Two types of measurements can be selected when using the central sensor:

- Internal relative humidity, i.e. a measurement of indoor air salubrity compared to the risk of mould proliferation. All units are equipped with a humidity sensor located in the extracted air duct (for standard units, the humidity sensor is available as an accessory).
- Concentration of carbon dioxide, i.e. a measurement of the level of internal occupation. The CO₂ sensor, not supplied, is a 0-10V type commonly available on the market, to be installed directly inside the occupied room.

Regardless of the type selected, the AUTO mode is only available if the sensor is physically connected to the main control board. If the CO₂ sensor and the humidity sensor are simultaneously connected to the main electronic board, the AUTO mode will refer to the measurements from the CO₂ sensor.

When installing in regions with particularly harsh climatic conditions, the units must be equipped with a pre-heating coil to prevent freezing phenomena on the discharge air outlet side. The electric heater can be installed on the fresh air intake section, see the next dedicated paragraph, or, only for the units from size 170 to size 600, the version with electric heater fitted on the unit (E version) is available. In this case the electric heater is fitted within the ventilation unit, near the fresh air inlet section.

If the fresh air temperature drops below the default limit, resulting in the risk of the counterflow heat exchanger freezing, the electric heater is switched on and the thermal power is adjusted continuously in order to maintain the discharge air temperature within the desired range.

The electric heater is sized so as to ensure internal thermal comfort up to an outside temperature of -10 °C and is designed to prevent the effects of frost while the temperature remains above -15 °C. The units are kept in normal operating conditions until the supply air temperature drops below 5 °C or until the outside temperature drops below -20 °C; when these limits are exceeded, the machine is switched off for antifreeze emergency reasons ("Frost" alarm).

The electric heater is fitted with a safety thermostat that turns off the unit in case of uncontrolled heating. In case the electric heater does not start up, instead, the unit will turn off if the supply air temperature falls below 5 °C.

ENY-SP and ENY-S vertical version	
Model	W
ENY-SP-180	500
ENY-SP-280	900
ENY-SP-370	1250
ENY-SP-460	1600
ENY-SP-600	2000
ENY-S-170	500
ENY-S-270	900
ENY-S-360	1250
ENY-S-460	1600
ENY-S-600	2000

ENY-SHP horizontal and vertical version	
Model	W
ENY-SHP-170	600
ENY-SHP-270	

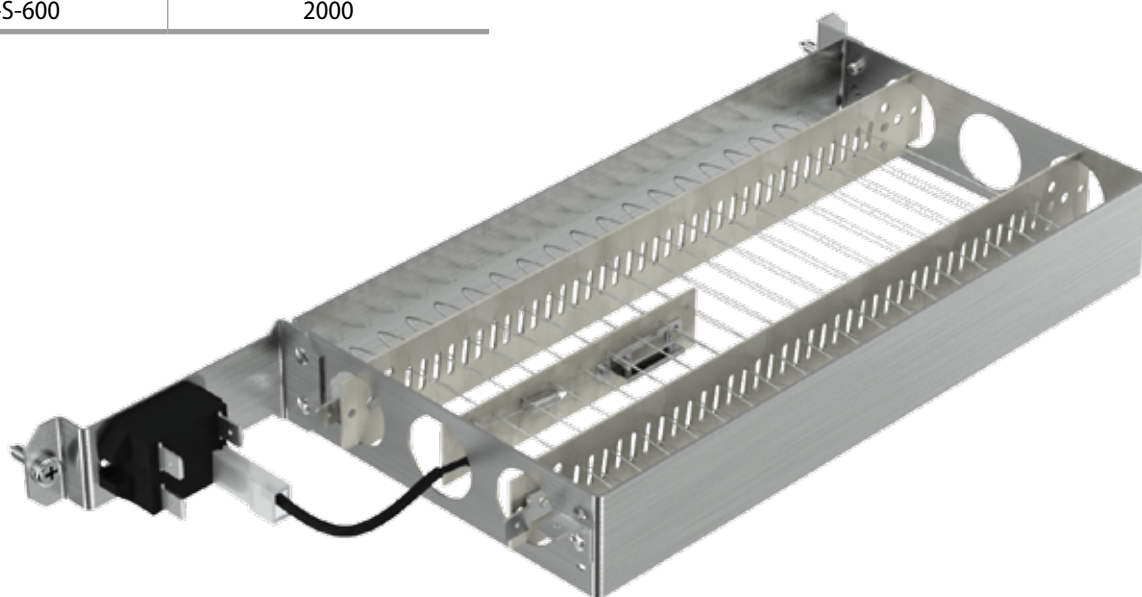

Circular electric external duct pre-heater

If a pre-heating coil is required only after the unit has been purchased, a circular electric heater accessory for duct application is available for each unit. The electric heater technology has been selected and developed for typical HVAC applications.

Armoured electric duct heaters have been used (single phase 230Vac - 50Hz power supply). The electric heater is equipped with all the required safety measures and is regulated through a modulated pulse width signal generated by the central PCB in response to operation of the PID controller.

ENY-SP and ENY-S vertical version

Model	Type	Code	W
ENY-SP-180	ES-E-600	9021105	600
ENY-SP-280	ES-E-900	9021106	900
ENY-SP-370	ES-E-1250	9021107	1250
ENY-SP-460	ES-E-1600	9021108	1600
ENY-SP-600	ES-E-2100	9021119	2100
ENY-S-170	ES-E-600	9021105	600
ENY-S-270	ES-E-900	9021106	900
ENY-S-360	ES-E-1250	9021107	1250
ENY-S-460	ES-E-1600	9021108	1600
ENY-S-600	ES-E-2100	9021119	2100

ENY-SP and ENY-S horizontal and vertical version

Model	Sigla	Codice	W
ENY-SHP-150	ES-E-600	9021105	600
ENY-SHP-170			
ENY-SHP-270	ES-E-900	9021106	900



Feet

Feet screwed in and lifting structure. The height of the feet can be adjusted from 200 to 225 mm.

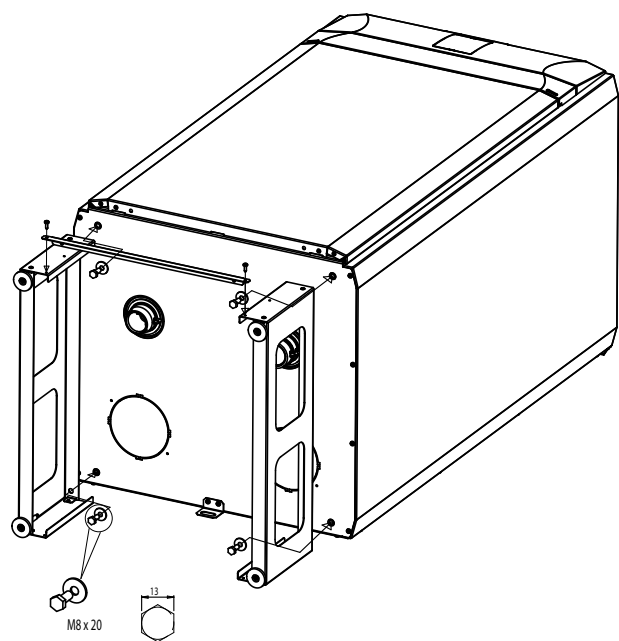

ENY-SP ed ENY-S vertical version

Model	Type	Code	A	B
ENY-SP-180	ES-P-180-270	9021312	523	534
ENY-SP-280	ES-P-280-360	9021313	523	584
ENY-SP-370	ES-P-370-600	9021314	583	634
ENY-SP-460	ES-P-370-600	9021314	583	634
ENY-SP-600	ES-P-370-600	9021314	583	634
ENY-S-170	ES-P-170	9021311	523	549
ENY-S-270	ES-P-180-270	9021312	523	534
ENY-S-360	ES-P-280-360	9021313	523	584
ENY-S-460	ES-P-370-600	9021314	583	634
ENY-S-600	ES-P-370-600	9021314	583	634

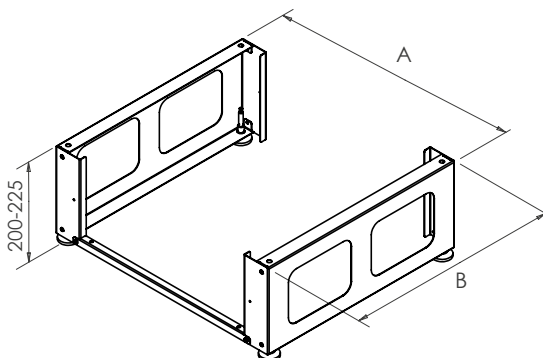

Pressure sensor for automatic control of ES-DP flow rates

(standard on ENY-SP, not available on ENY-SHP units)

ENY-S units can be equipped with an automatic flow rate control device. The calibration system of standard units consists in a manual balancing operation performed by the responsible technician, using a digital pressure gauge. After the first calibration, the unit control board is programmed to maintain the nominal and partial flow rate close to the desired value through fan speed control (indirect flow rate control method). Alternatively, an advanced control strategy is envisaged, enabling automatic flow rate calibration and maintaining it thanks to the action of differential pressure switches connected to the suction nozzles of the centrifugal fans. The pressure drop measured by this type of sensors is directly related to the flow rate of the fans, so that it can be considered as a direct flow rate measurement. If the units are equipped with accessory transmitters, the main control board detects the actual system flow rates at all times, making it react automatically to maintain the desired actual values.

Type	Code
ES-DP	9021200



Automatic control system
operating diagram

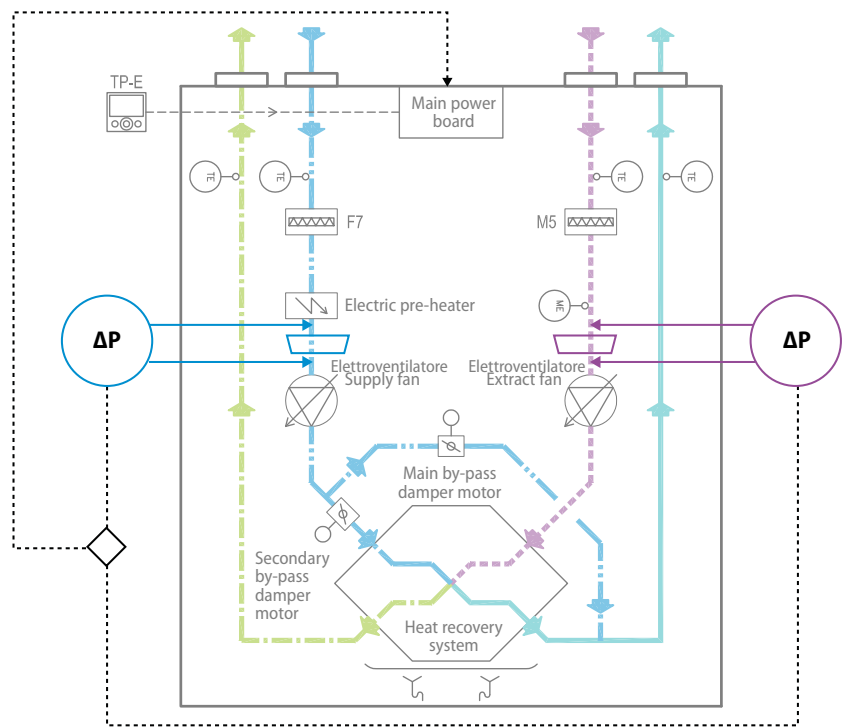

Below are the main benefits of installing an automatic flow rate control system on the units:

Topic	Benefits
The flow rate calibration is much easier	The system simply asks for the desired flow rate value and configures it automatically without any further intervention. No pressure gauges are required.
The flow rate is not affected by filter clogging	Without the automatic flow rate control system, failure to periodically replace the filters leads to an inevitable reduction in the flow rate that the unit manages to deliver. The system with direct measurement of the exchange flow rate through pressure transducers ensures that the flow rate stays constant regardless of the extent of filter clogging. The filters should however be replaced regularly according to the rules recommended in this brochure (see "Conformity Table with Regulations EU 1253/14 and EU 1254/14"), since in any case filter clogging leads to a significant increase in the electric power consumption of the unit and does not guarantee the best hygienic standards.

The automatic flow rate control system is compatible with the "AUTO" variable flow modes.

Capacitive humidity sensor

(standard on ENY-SP)

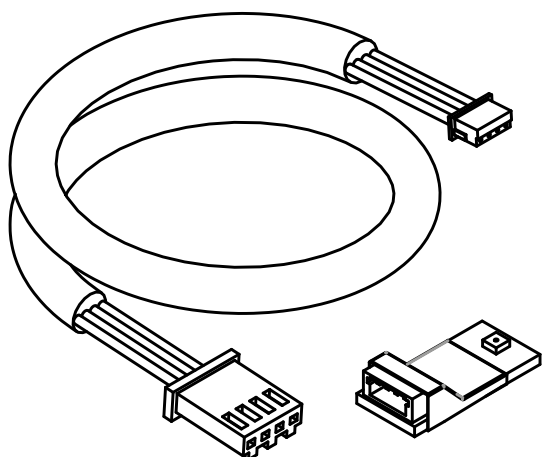

Type	Code
ES-SU	9021218

KNX Interface kit

The Energy Smart units can be monitored and controlled by a Modbus system and also by a KNX supervisory system. The Energy Smart Recovery Unit connection to the Konnex standard of building automatization is possible with the KNX interface board, available as accessory.

Such a board is supplied with the connecting cable for the same interface board to the electronic board of Energy Smart unit and the support for fastening during a speedy and easy installation within the ventilation unit.



Type	Code
KNX-RVU	9021109

Check availability for ENY-SHP-270 models.

Compliance with EU 1253/14

VERIFICATION ITEM	DECLARATION OF CONFORMITY
The VUs must be equipped with multiple speed drive or speed variator.	The units are equipped with centrifugal fans featuring backward-curved blades directly coupled with brushless synchronous electronic motors, with integrated inverter for continuous modulating speed through 0-10 V control signal.
The SEC value, calculated for an average climate, should not exceed 0 kWh/(m ² .a)	For models ENY-SHP-170, ENY-SP-180/280/370 , which belong to energy class A+, the SEC is below -42 kWh/m ² a. For models ENY-S-170/270/360/460/600, ENY-SP-460/600 and ENY-SHP-270 which belong to energy class A, the SEC is below 0 or equal to -38 kWh/m ² a.
All BVUs must be equipped with a thermal bypass device	To ensure the maximum amount of free-cooling, all units are provided with by-pass dampers for total by-pass of the heat recovery unit by the supply air flow.

Note: Regulation EU 1253/14 does not apply to the ENY-SHP-150 unit as the nominal power input of each fan is less than 30W

In Compliance with EU 1254/14 - Annex IV

Table of compliance with Regulations EU 1254/14 Annex IV - Energy Smart

Supplier name or brand	Sabiana SpA														
Supplier model identification	ENY-SP-180			ENY-SP-280			ENY-SP-370			ENY-SP-460			ENY-SP-600		
Specific energy consumption SEC in [kWh/(m ² a)] for each applicable climate zone (temperate, hot, cold, climate)	-42,32	-17,2	-81,6	-42,29	-17,2	-81,6	-42,47	-17,2	-82,0	-40,10	-15,4	-78,6	-39,71	-15,1	-78,1
SEC class - temperate climatic zone	A+			A+			A+			A			A		
Type declared according to EU 1253/14	BVU			BVU			BVU			BVU			BVU		
Type of drive installed	Continuous speed variator			Continuous speed variator			Continuous speed variator			Continuous speed variator			Continuous speed variator		
Type of heat recovery system	Static sensitive heat recovery unit			Static sensitive heat recovery unit			Static sensitive heat recovery unit			Static sensitive heat recovery unit			Static sensitive heat recovery unit		
Thermal efficiency	91,5%			91,4%			92,5%			88,6%			88,0%		
Maximum flow rate [m ³ /h] ³	180			280			370			460			600		
Power absorbed by the fan drive, including all motor control devices, at maximum flow rate [W] ⁴	50			70			120			215			300		
Sound power level (LWA) in [dB(A)]	38,9			43,1			46,3			47,9			52,4		
Reference flow rate [m ³ /h]	130			200			260			320			420		
Reference pressure difference [Pa]	50			50			50			50			50		
SPI [W/(m ³ /h)]	0,174			0,174			0,179			0,237			0,247		
Control factor and type of control	0,85 Centralised ambient control with humidity sensor			0,85 Centralised ambient control with humidity sensor			0,85 Centralised ambient control with humidity sensor			0,85 Centralised ambient control with humidity sensor			0,85 Centralised ambient control with humidity sensor		
Maximum percentages declared [%] of internal and external leakage	Internal leakage: 1,2%			Internal leakage: 0,7%			Internal leakage: 0,5%			Internal leakage: 0,3%			Internal leakage: 0,6%		
	External leakage: 1,7%			External leakage: 1,0%			External leakage: 0,8%			External leakage: 0,7%			External leakage: 1,84%		
Position and description of the visual warning signal relating to the filter for RVUs intended for use with filters, including a text that emphasizes the importance of replacing the filter at regular intervals in order to safeguard unit performance and energy efficiency	Please refer to the following parts of the brochure: <ul style="list-style-type: none"> • T-EP control description • Recommendations for filter replacement: filters clogging could result into relevant flow rate reduction, which implies the need of frequent windows opening and consequent thermal demand increase. • Proper replacement period depends on background air quality, which can broadly vary between city centers and countryside. • In order to prevent filters clogging, optimum average period for filters replacement is 3 month. However, due to normal dust collection and spring pollens, maximum suggested period should not exceed 6 months. • Filters replacement period can be modified by maintainer with a precision of days (min 30, max 360). 														
Internet address with the disassembly instructions	www.sabiana.it			www.sabiana.it			www.sabiana.it			www.sabiana.it			www.sabiana.it		
AEC (Annual Energy Consumption) [kWh/a]	203	158	740	203	158	740	207	162	744	260	215	797	269	224	806
AHS (Annual Heating Energy Savings) [kWh/a]	4670	2111	9136	4667	2110	9131	4697	2124	9189	4591	2076	8982	4576	2069	8951

In Compliance with EU 1254/14 - Annex IV

Table of compliance with Regulation EU 1254/14 Annex IV - Energy Smart

Supplier name or brand	Sabiana SpA														
	ENY-S-170			ENY-S-270			ENY-S-360			ENY-S-460			ENY-S-600		
Supplier model identification															
Specific energy consumption SEC in [kWh/(m ² a)] for each applicable climate zone (temperate, hot, cold, climate)	-39,4	-15,2	-77,2	-39,3	-15,1	-76,9	-39,7	-14,9	-78,3	-38,4	-13,9	-76,6	-37,9	-13,5	-76,0
SEC class - temperate climatic zone	A			A			A			A			A		
Type declared according to EU 1253/14	BVU			BVU			BVU			BVU			BVU		
Type of drive installed	Continuous speed variator			Continuous speed variator			Continuous speed variator			Continuous speed variator			Continuous speed variator		
Type of heat recovery system	Static sensitive heat recovery unit			Static sensitive heat recovery unit			Static sensitive heat recovery unit			Static sensitive heat recovery unit			Static sensitive heat recovery unit		
Thermal efficiency	87,0%			86,5%			90,1%			88,6%			88,0%		
Maximum flow rate [m ³ /h] ³	170			270			360			460			600		
Power absorbed by the fan drive, including all motor control devices, at maximum flow rate [W] ⁴	45			76			125			215			300		
Sound power level (LWA) in [dB(A)]	40,6			46,6			49,0			47,9			52,4		
Reference flow rate [m ³ /h]	120			190			250			320			420		
Reference pressure difference [Pa]	50			50			50			50			50		
SPI [W/(m ³ /h)]	0,183			0,184			0,209			0,237			0,247		
Control factor and type of control	0,95 Timer control			0,95 Timer control			0,95 Timer control			0,95 Timer control			0,95 Timer control		
Maximum percentages declared [%] of internal and external leakage	Internal leakage: 0,4%			Internal leakage: 0,4%			Internal leakage: 0,7%			Internal leakage: 0,3%			Internal leakage: 0,6%		
	External leakage: 1,8%			External leakage: 1,4%			External leakage: 2,7%			External leakage: 0,7%			External leakage: 1,84%		
Position and description of the visual warning signal relating to the filter for RVUs intended for use with filters, including a text that emphasizes the importance of replacing the filter at regular intervals in order to safeguard unit performance and energy efficiency	<p>Please refer to the following parts of the brochure:</p> <ul style="list-style-type: none"> • T-EP control description • Recommendations for filter replacement: filters clogging could result into relevant flow rate reduction, which implies the need of frequent windows opening and consequent thermal demand increase. • Proper replacement period depends on background air quality, which can broadly vary between city centers and countryside. • In order to prevent filters clogging, optimum average period for filters replacement is 3 month. However, due to normal dust collection and spring pollens, maximum suggested period should not exceed 6 months. • For "ENY-S" range, in case where optional automatic flow system is provided, neglected filters replacement does not result into air flow decrease, however it would imply relevant power consumption increase. As a matter of fact, fans energy consumption due to filters operation could rise up by 2 or 3 times. • Filters replacement period can be modified by maintainer with a precision of days (min 30, max 360). 														
Internet address with the disassembly instructions	www.sabiana.it			www.sabiana.it			www.sabiana.it			www.sabiana.it			www.sabiana.it		
AEC (Annual Energy Consumption) [kWh/a]	252	207	789	253	208	790	281	236	818	313	268	850	325	280	862
AHS (Annual Heating Energy Savings) [kWh/a]	4507	2038	8817	4492	2031	8787	4601	2080	8787	4555	2060	8912	4537	2052	8876

In Compliance with EU 1254/14 - Annex IV

Table of compliance with Regulation EU 1254/14 Annex IV - Energy Smart

Supplier name or brand	Sabiana SpA								
Supplier model identification	ENY-SHP-150			ENY-SHP-170			ENY-SHP-270		
Specific energy consumption SEC in [kWh/(m ² a)] for each applicable climate zone (temperate, hot, cold, climate)	-39,9	-15,4	-78,0	-42,05	-16,8	-81,5	-38,9	-14,8	-76,4
SEC class - temperate climatic zone	A			A+			A		
Type declared according to EU 1253/14	BVU			BVU			UVB		
Type of drive installed	Continuous speed variator			Continuous speed variator			Continuous speed variator		
Type of heat recovery system	Static sensitive heat recovery unit			Static sensitive heat recovery unit			Static sensitive heat recovery unit		
Thermal efficiency	87,0%			92,1%			84,4%		
Maximum flow rate [m ³ /h] ³	150			170			270		
Power absorbed by the fan drive, including all motor control devices, at maximum flow rate [W] ⁴	59			50			105		
Sound power level (LWA) in [dB(A)]	38,0			44,9			41,3		
Reference flow rate [m ³ /h]	105			120			190		
Reference pressure difference [Pa]	50			50			50		
SPI [W/(m ³ /h)]	0,227			0,193			0,240		
Control factor and type of control	0,85 Centralised ambient control with humidity sensor			0,85 Centralised ambient control with humidity sensor			0,85 Centralised ambient control with humidity sensor		
Maximum percentages declared [%] of internal and external leakage	Internal leakage: 1,8%			Internal leakage: 0,5%			Internal leakage: 0,4%		
	External leakage: 0,8%			External leakage: 2,3%			External leakage: 1,1%		
Position and description of the visual warning signal relating to the filter for RVUs intended for use with filters, including a text that emphasizes the importance of replacing the filter at regular intervals in order to safeguard unit performance and energy efficiency	Please refer to the following parts of the brochure: <ul style="list-style-type: none"> • T-EP control description • Recommendations for filter replacement: filters clogging could result into relevant flow rate reduction, which implies the need of frequent windows opening and consequent thermal demand increase. • Proper replacement period depends on background air quality, which can broadly vary between city centers and countryside. • In order to prevent filters clogging, optimum average period for filters replacement is 3 month. However, due to normal dust collection and spring pollens, maximum suggested period should not exceed 6 months. • Filters replacement period can be modified by maintainer with a precision of days (min 30, max 360) 								
Internet address with the disassembly instructions	www.sabiana.it			www.sabiana.it			www.sabiana.it		
AEC (Annual Energy Consumption) [kWh/a]	250	205	787	220	175	757	262	217	799
AHS (Annual Heating Energy Savings) [kWh/a]	4548	2057	8898	4690	2120	9170	4478	2025	8760



Costruzione e vendita di apparecchi per riscaldamento e condizionamento industriale e civile



Oggetto: Dichiarazione di conformità UE

Object: EU Declaration of conformity

La presente dichiarazione di conformità è rilasciata sotto la responsabilità esclusiva del fabbricante.

This declaration of conformity is issued under the exclusive responsibility of the manufacturer.

Prodotto: Energy Smart - Recuperatori Versione ENY-SHP-150

Product: Energy Smart - ENY-SHP-150 Recovery Units

Modello / Pattern: ENY-SHP-150

al quale questa dichiarazione si riferisce, è conforme alle seguenti norme:

to which this declaration relates is in conformity with the following standards or other normative document(s):

EN 60335-1 (2012) + A11 (2014) + A13 (2017) + A1 (2019) + A14 (2019) + A2 (2019) + A15 (2021)

EN 60335-2-80 (2003) + A1 (2004) + A2 (2009)

EN 62233 (2008)

EN IEC 55014-1 (2021)

EN IEC 55014-2 (2021)

EN 61000-3-2 (2019)

EN 61000-3-3 (2013) + A1 (2019)

EN IEC 63000 (2018)

Regulation (UE) 1253/14

Regulation (UE) 1254/14

Regulation (EC) 1907/2006

L'oggetto della dichiarazione di cui sopra è conforme alla pertinente normativa di armonizzazione dell'Unione.

The object of the declaration described above is in conformity with the relevant Union harmonization legislation.

2014/35/UE 2014/30/UE 2006/42/EC 2011/65/UE 2014/53/UE

Il fascicolo tecnico è costituito presso: Sabiana S.p.A. Via Piave 53, 20011 Corbetta (MILANO-ITALY)

The technical file is made at: Sabiana S.p.A. Via Piave 53, 20011 Corbetta (MILANO-ITALY)

Corbetta, 10/01/2022

Nicola Binaghi
Presidente

SABIANA SpA Società a socio unico
Sede Legale e stabilimento:
via Piave 53 - 20011 Corbetta (MI) Italia
Direzione e coordinamento: Arbonia AG

E-mail: info@sabiana.it
Pec: info@pec.sabiana.it
T. +39 02 972031 r.a.
F. +39 02 9777282

Cap. Sociale € 4.060.000 int. vers.
C.F./P. IVA IT 09076750158
Reg. Imprese MI 09076750158
C.C.I.A.A. n. R.E.A. 1267681 Milano

A company of Arbonia Group
ARBONIA



Costruzione e vendita di apparecchi per riscaldamento e condizionamento industriale e civile

**Oggetto: Dichiarazione di conformità UE****Object: EU Declaration of conformity****La presente dichiarazione di conformità è rilasciata sotto la responsabilità esclusiva del fabbricante.****This declaration of conformity is issued under the exclusive responsibility of the manufacturer.****Prodotto:** Energy Smart - Recuperatori Versione Orizzontale e Verticale**Product:** Energy Smart - Horizontal and Vertical Recovery Units**Modello / Pattern:** ENY-SHP-170, ENY-SHPEL-170, ENY-SHPER-170,
ENY-SHPM-170, ENY-SHPMEL-170, ENY-SHPMER-170**al quale questa dichiarazione si riferisce, è conforme alle seguenti norme:****to which this declaration relates is in conformity with the following standards or other normative document(s):****EN 60335-1** (2012) + A11 (2014) + A13 (2017) + A1 (2019) + A14 (2019) + A2 (2019) + A15 (2021)**EN 60335-2-80** (2003) + A1 (2004) + A2 (2009)**EN 62233** (2008)**EN IEC 55014-1** (2021)**EN IEC 55014-2** (2021)**EN 61000-3-2** (2019)**EN 61000-3-3** (2013) + A1 (2019)**EN IEC 63000** (2018)**Regulation (UE) 1253/14****Regulation (UE) 1254/14****Regulation (EC) 1907/2006****L'oggetto della dichiarazione di cui sopra è conforme alla pertinente normativa di armonizzazione dell'Unione.****The object of the declaration described above is in conformity with the relevant Union harmonization legislation.****2014/35/UE 2014/30/UE 2006/42/EC 2011/65/UE 2014/53/UE**

Il fascicolo tecnico è costituito presso: Sabiana S.p.A. Via Piave 53, 20011 Corbetta (MILANO-ITALY)

The technical file is made at: Sabiana S.p.A. Via Piave 53, 20011 Corbetta (MILANO-ITALY)

Corbetta, 10/01/2022

Nicola Binaghi
Presidente



SABIANA SpA Società a socio unico
Sede Legale e stabilimento:
via Piave 53 - 20011 Corbetta (MI) Italia
Direzione e coordinamento: Arbonia AG

E-mail: info@sabiana.it
Pec: info@pec.sabiana.it
T. +39 02 97203 1 r.a.
F. +39 02 9777282

Cap. Sociale: € 4.050.000 int. vers.
C. F. / P. NA IT 09076750158
Reg. Imprese MI 09076750158
C.C.I.A.A. n. R.E.A. 1267681 Milano

A company of Arbonia Group
ARBONIA



Costruzione e vendita di apparecchi per riscaldamento e condizionamento industriale e civile



Oggetto: **Dichiarazione di conformità UE**

Object: **EU Declaration of conformity**

La presente dichiarazione di conformità è rilasciata sotto la responsabilità esclusiva del fabbricante.
This declaration of conformity is issued under the exclusive responsibility of the manufacturer.

Prodotto: Energy Smart - Recuperatori di calore ENY-SHP-270

Product: Energy Smart - ENY-SHP-270 Heat Recovery Unit

Modello / Pattern: ENY-SHPL-270, ENY-SHPR-270, ENY-SHPML-270, ENY-SHPMR-270
ENY-SHPEL-270, ENY-SHPER-270, ENY-SHPMEL-270, ENY-SHPMER-270

al quale questa dichiarazione si riferisce, è conforme alle seguenti norme:

to which this declaration relates is in conformity with the following standards or other normative document(s):

EN 60335-1 (2012) + A11 (2014) + A13 (2017) + A1 (2019) + A14 (2019) + A2 (2019) + A15 (2021)

EN 60335-2-40 (2003) + A11 (2004) + A12 (2005) + A1 (2006) + A2 (2009) + A13 (2012)

EN 60335-2-80 (2003) + A1 (2004) + A2 (2009)

EN 62233 (2008)

EN IEC 55014-1 (2021)

EN IEC 55014-2 (2021)

EN 61000-3-2 (2019)

EN 61000-3-3 (2013) + A1 (2019)

EN IEC 63000 (2018)

L'oggetto della dichiarazione di cui sopra è conforme alla pertinente normativa di armonizzazione dell'Unione.

The object of the declaration described above is in conformity with the relevant Union harmonization legislation.

2014/35/UE 2014/30/UE 2006/42/EC 2011/65/UE 2014/53/UE

Il fascicolo tecnico è costituito presso: Sabiana S.p.A. Via Piave 53, 20011 Corbetta (MILANO-ITALY)

The technical file is made at: Sabiana S.p.A. Via Piave 53, 20011 Corbetta (MILANO-ITALY)

Corbetta, 10-01-2022

Nicola Binaghi
Presidente



Costruzione e vendita di apparecchi per riscaldamento e condizionamento industriale e civile:



Oggetto: **Dichiarazione di conformità UE**
 Object: **EU Declaration of conformity**

La presente dichiarazione di conformità è rilasciata sotto la responsabilità esclusiva del fabbricante.
This declaration of conformity is issued under the exclusive responsibility of the manufacturer.

Prodotto: Energy Smart - Recuperatori Versione Verticale
Product: Energy Smart - Vertical Recovery Units

Modello / Pattern: ENY-SP-180, ENY-SP-280, ENY-SP-370, ENY-SP-460, ENY-SP-600,
 ENY-SPEL-180, ENY-SPEL-280, ENY-SPEL-370, ENY-SPEL-460, ENY-SPEL-600,
 ENY-SPER-180, ENY-SPER-280, ENY-SPER-370, ENY-SPER-460, ENY-SPER-600,
 ENY-SPM-180, ENY-SPM-280, ENY-SPM-370, ENY-SPM-460,
 ENY-SPMEL-180, ENY-SPMEL-280, ENY-SPMEL-370, ENY-SPMEL-460,
 ENY-SPMER-180, ENY-SPMER-280, ENY-SPMER-370, ENY-SPMER-460,
 ENY-S-170, ENY-S-270, ENY-S-360, ENY-S-460, ENY-S-600,
 ENY-SEL-170, ENY-SEL-270, ENY-SEL-360, ENY-SEL-460, ENY-SEL-600,
 ENY-SER-170, ENY-SER-270, ENY-SER-360, ENY-SER-460, ENY-SER-600.

al quale questa dichiarazione si riferisce, è conforme alle seguenti norme:
to which this declaration relates is in conformity with the following standards or other normative document(s):

EN 60335-1 (2012) + A11 (2014) + A13 (2017) + A1 (2019) + A14 (2019) + A2 (2019) + A15 (2021)

EN 60335-2-40 (2003) + A11 (2004) + A12 (2005) + A1 (2006) + A2 (2009) + A13 (2012)

EN 60335-2-80 (2003) + A1 (2004) + A2 (2009)

EN 62233 (2008)

EN IEC 55014-1 (2021)

EN IEC 55014-2 (2021)

EN 61000-3-2 (2019)

EN 61000-3-3 (2013) + A1 (2019)

EN IEC 63000 (2018)

Regulation (UE) 1253/14

Regulation (UE) 1254/14

Regulation (EC) 1907/2006

L'oggetto della dichiarazione di cui sopra è conforme alla pertinente normativa di armonizzazione dell'Unione.
The object of the declaration described above is in conformity with the relevant Union harmonization legislation.

2014/35/UE 2014/30/UE 2006/42/EC 2011/65/UE 2014/53/UE

Il fascicolo tecnico è costituito presso: Sabiana S.p.A. Via Piave 53, 20011 Corbetta (MILANO-ITALY)
 The technical file is made at: Sabiana S.p.A. Via Piave 53, 20011 Corbetta (MILANO-ITALY)

Corbetta, 10/01/2022

Nicola Binaghi
 Presidente

SABIANA SpA Società a socio unico
 Sede Legale e stabilimento:
 via Piave 53 - 20011 Corbetta (MI) Italia
 Direzione e coordinamento: Arbonia AG

E-mail: info@sabiana.it
 Pec: info@pec.sabiana.it
 T. +39 02 97203 3 r.a.
 F. +39 02 9777282

Cap. Sociale € 4.060.000 int. vers.
 C. F./P. IVA IT 09076750158
 Reg. Imprese MI 09076750158
 C.C.I.A.A. n. REA. 1267681 Milano

A company of Arbonia Group
ARBONIA

CERTIFICATE

Certified Passive House Component

Component-ID 0958vs03 valid until 31st December 2022

Passive House Institute
Dr. Wolfgang Feist
64283 Darmstadt
Germany

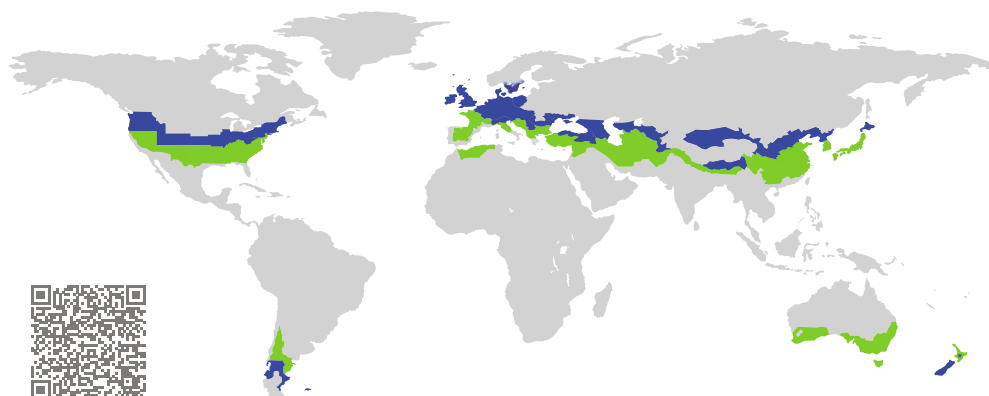

Category: **Air handling unit with heat recovery**
 Manufacturer: **Sabiana s.p.a. Italy**
 Product name: **ENY-SP-280**

Specification: Airflow rate < 600 m³/h
 Heat exchanger: Recuperative

This certificate was awarded based on the product meeting the following main criteria

Heat recovery rate $\eta_{HR} \geq 75\%$
 Specific electric power $P_{el,spec} \leq 0.45 \text{ Wh/m}^3$
 Leakage < 3%
 Comfort Supply air temperature $\geq 16.5 \text{ }^\circ\text{C}$ at outdoor air temperature of $-10 \text{ }^\circ\text{C}$

Airflow range	129–164 m ³ /h
Heat recovery rate	$\eta_{HR} = 88\%$
Specific electric power	$P_{el,spec} = 0.25 \text{ Wh/m}^3$



www.passivehouse.com

Sabiana s.p.a.

Via Piave 53, 20011 Corbetta (MI), Italy

☎ +39 02 972031 | ✉ info@sabiana.it | 🌐 http://www.sabiana.it |

Passive House comfort criterion

A minimum supply air temperature of 16.5 °C is maintained at an outdoor air temperature of -10 °C.

Efficiency criterion (heat recovery rate)

The effective heat recovery rate is measured at a test facility using balanced mass flows of the outdoor and exhaust air. The boundary conditions for the measurement are documented in the testing procedure.

$$\eta_{HR} = \frac{(\theta_{ETA} - \theta_{EHA}) + \frac{P_{el}}{\dot{m} \cdot c_p}}{(\theta_{ETA} - \theta_{ODA})}$$

With

 η_{HR} Heat recovery rate in % θ_{ETA} Extract air temperature in °C θ_{EHA} Exhaust air temperature in °C θ_{ODA} Outdoor air temperature in °C P_{el} Electric power in W \dot{m} Mass flow in kg/h c_p Specific heat capacity in Wh/(kg K)**Heat recovery rate**

$$\eta_{HR} = 88 \%$$

Efficiency criterion (electric power)

The overall electrical power consumption of the device is measured at the test facility at an external pressure of 100 Pa (50 Pa, respectively, for the intake and outlet). This includes the general electrical power consumption for operation and control but not for frost protection.

Specific electric power

$$P_{el,spec} = 0.25 \text{ Wh/m}^3$$

Efficiency ratio

The efficiency ratio provides information about the overall energy performance of the respective ventilation unit. It specifies the achieved reduction in ventilation heat losses by using a ventilation unit with heat recovery rather than without.

Efficiency ratio

$$\epsilon_L = 0.71$$

Leakage

The leakage airflow must not exceed 3% of the average airflow of the unit's operating range.

Internal leakage	External leakage
0.96 %	0.61 %

Settings and airflow balance

It must be possible to adjust the balance of airflows at the unit itself (either between the exhaust and the outdoor airflows or between the supply and the extract airflows, if the unit is respectively placed inside or outside of the insulated thermal envelope of the building).

- This unit is certified for airflow rates of 129–164 m³/h.
- Balancing the airflow rates of the unit is possible.
- The user should have at least all the following setting options:
 - ✓ Switching the system on and off.
 - ✓ Synchronized adjustment of the supply and extract airflows to basic ventilation (70–80 %), standard ventilation (100 %) and increased ventilation (130 %) with a clear indication of the current setting.
- The device has a standby power consumption of 0.80 W. Hereby complies with the target value of 1 W.
- After a power failure, the device will automatically resume operation.

Acoustical testing

The required limit for the sound power level of the device is 35 dB(A) in order to limit the sound pressure level in the installation room. The sound level target value of less than 25 dB(A) in living spaces and less than 30 dB(A) in functional spaces must be ensured by installing commercial silencers. The following sound power levels are met at an airflow rate of 166 m³/h:

Device	Duct			
	Outdoor	Supply air	Extract air	Exhaust air
44.9 dB(A)	55.3 dB(A)	44.3 dB(A)	59.1 dB(A)	52.4 dB(A)

- The unit does not fulfil the requirements for the sound power level. The unit must therefore be installed acoustically separated from living areas.
- One example of suitable silencers for supply and extract air ducts is mentioned in the detailed test report or can be obtained from the manufacturer. It is recommended to identify suitable silencers for each individual project.

Indoor air quality

This unit is to be equipped with the following filter qualities:

Outdoor air filter	Extract air filter
ISO ePM1 50%	ISO Coarse 60%

On the outdoor air side, the filter efficiency of ISO ePM1 50% (F7 according to EN 779) or better is recommended. For the extract air side, a filter efficiency of at least ISO Coarse 60% (G4 according to EN 779) is recommended. If not in standard configuration, the recommended filter is available as an accessory part.

Frost protection

Appropriate measures should be taken to prevent the heat exchanger and optional downstream hydraulic heater coil from getting damaged by frost during extreme winter temperatures ($-15\text{ }^{\circ}\text{C}$). It must be ensured that the unit's ventilation performance is not affected during frost protection cycles.

- Frost protection of the heat exchanger:
 - ✓ In order to protect the heat exchanger from freezing, for cool-temperate climate, the unit is equipped as standard with an electrical preheater. The frost protection strategy is appropriate to protect the heat exchanger from frost down to an outdoor air temperature of $-15\text{ }^{\circ}\text{C}$ (verified by measurement results). The unit can also be equipped with a hydraulic heater.
- Frost protection of downstream hydraulic heater coils:
 - ✓ This unit provides a frost protection of the downstream hydraulic heater coils. In the case the hydraulic post-heating coil is used, the unit is automatically switched off when the supply air temperatures drops below $5\text{ }^{\circ}\text{C}$.



A company of Arbonia Group
ARBONIA 

Follow us on



Sabiana app



SABIANA SpA

Società a socio unico

Via Piave 53 - 20011 Corbetta (MI) Italia

T. +39 02 97203 1 r.a. • F. +39 02 9777282

info@sabiana.it

www.sabiana.it